



A.R.M. (USA), INC
 1506 Fernwood Rd.
 Wintersville, OH 43953
 740.264.6599
 740.266.2953 Fax

Bulletin No: SB20180221
Release Date: February 21, 2018
Effective Date: March 1, 2018
Supersedes: N/A
Completion Date: May 30, 2018
Page: 1 of 7

SERVICE BULLETIN

Manufacturer: A.R.M. (USA), Inc.
 Ride Name: Super Shot

Model(s): All
 Affected Production Dates: All

**AFFECTED
 SERIAL
 NUMBERS**

ABSTRACT OF ISSUE

Mandatory installation of secondary locking mechanism to prevent passenger seats from dislodging in the event seat attachment bolts are not installed.

All Rides
 Fixed-Site & Mobile

REASON FOR RELEASE

A.R.M. (USA), Inc. has been notified of an incident in which a seat became detached from the carriage frame during operation. Investigation indicates the seat frame attachment bolts were not installed at the time of the incident.

ACTION TO BE TAKEN

1. Immediate installation of secondary locking mechanism on all seat frames per attached instructions;
2. Replace all seat attachment bolts, washers and nuts;
3. Modify inspection protocol to include daily inspection of latches and mounting hardware;
4. Modify maintenance protocol to include annual replacement of all seat attachment bolts;
5. Execute the Certificate of Compliance form and return to A.R.M. (USA), Inc. prior to continued operation beyond the Compliance Date of this Service Bulletin.

DETAIL OF ISSUE

A bolt-on locking device has been developed to prevent the seat frames from detaching from the carriage frame in the event the attachment bolts are missing or improperly installed.



The Secondary Lock Mechanism Is Not Intended, Or Capable Of, Replacing The Primary Seat Attachment Bolts. Under No Circumstances May The Ride Be Operated With Any Of The Seat Bolts Missing Or Improperly Installed.

There have been two primary styles of seat carriages produced for the Super Shot line of rides; A "square" frame with three seats on each of the four sides of the tower and a "round" dodecagon (12 sided) frame with a single seat on each face. Each style requires a different lock kit.

Square Seat Carriage = Kit #SS0129
 Round Seat Carriage = Kit #SS1002

Upon receipt of this Service Bulletin, contact A.R.M. (USA), Inc. and provide the following:

1. Company Name;
2. Ride Serial Number;
3. Seat Carriage Style (square or round); and
3. Specific Shipping Instructions

Upon receipt of the kits, immediately install per instructions and add daily visual inspection of the latches and mounting hardware to inspection protocol.

NOTICE

ONLY COMPONENTS SPECIFIED, AUTHORIZED, OR PROVIDED BY A.R.M. (US), INC. SHALL BE USED
 A.R.M. (US) INC. SPECIFICALLY DISCLAIMS ANY LIABILITY ASSOCIATED WITH THE USE OF
 UNAUTHORIZED COMPONENTS OR MODIFICATIONS AND/OR ALTERATIONS OF AUTHORIZED COMPONENTS.



A.R.M. (USA), INC
1506 Fernwood Rd.
Wintersville, OH 43953
740.264.6599
740.266.2953 Fax

Bulletin No: SB20180221
Release Date: February 21, 2018
Effective Date: March 1, 2018
Supercedes: N/A
Completion Date: May 30, 2018
Page: 1 of 7

Certification of Compliance

Operation Of Ride To Cease If This Certification Of Compliance Has Not Been Executed And Received By A.R.M. (USA), Inc. By The Completion Date Of This Service Bulletin.

1. The Super Shot passenger seat secondary latch kit has been installed per instructions included in Service Bulletin SB20180221;
2. All seat attachment bolts, washers and nuts have been replaced and torqued to 60lb/ft;
3. Inspection protocol has been modified to include daily visual inspection of the secondary latches, mounting hardware and fasteners.
4. Maintenance protocol has been modified to include annual replacement of all seat attachment bolts.

Compliance Completion Date

Ride Specifics

Ride Serial Number

Owner / Operator

Representative Credentials

Printed Name

Title

Signature

Submit completed Certification of Compliance via postal mail, e-mail or FAX:

A.R.M. (USA), Inc
1506 Fernwood Rd
Wintersville, OH 43953
armbulletin@armrides.com
740.266.2953 FAX

Kit SS0129 - Round Carriage Frame

PART NUMBER	DESCRIPTION	QTY.
SS0128	Seat Lock Base	1
107420	Latch - Austin AH2695SS	1
103726	Washer - 1/4" SAE Flat GR2 Zinc	13
105095	Bolt - 1/4"-20 X 1" Hex GR5 Zinc	9
107498	Nut - 1/4"-20 Hex NE Zinc Nylon Lock	9

Kit SS1002 - Square Carriage Frame

PART NUMBER	DESCRIPTION	QTY.
SS1003	Seat Lock Base	1
107420	Latch - Austin AH2695SS	1
103726	Washer - 1/4" SAE Flat GR2 Zinc	12
105095	Bolt - 1/4"-20 X 1" Hex GR5 Zinc	8
107498	Nut - 1/4"-20 Hex NE Zinc Nylon Lock	8

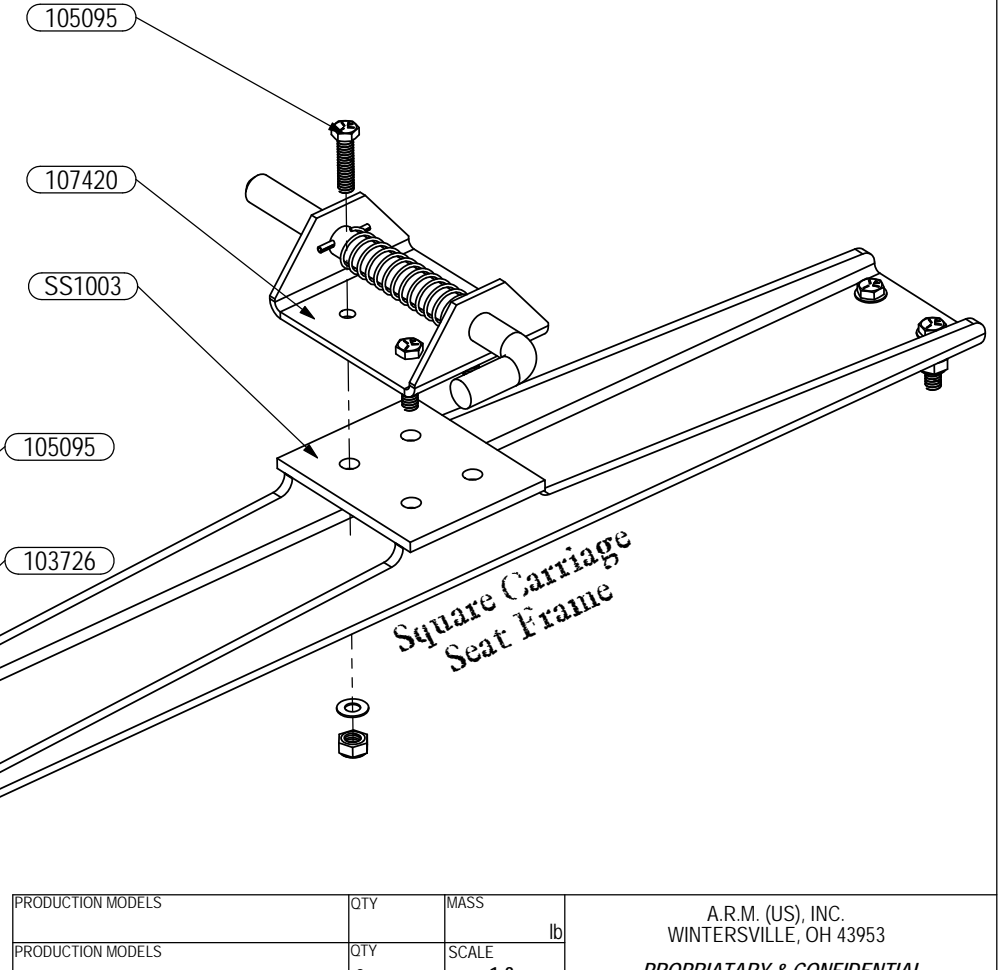
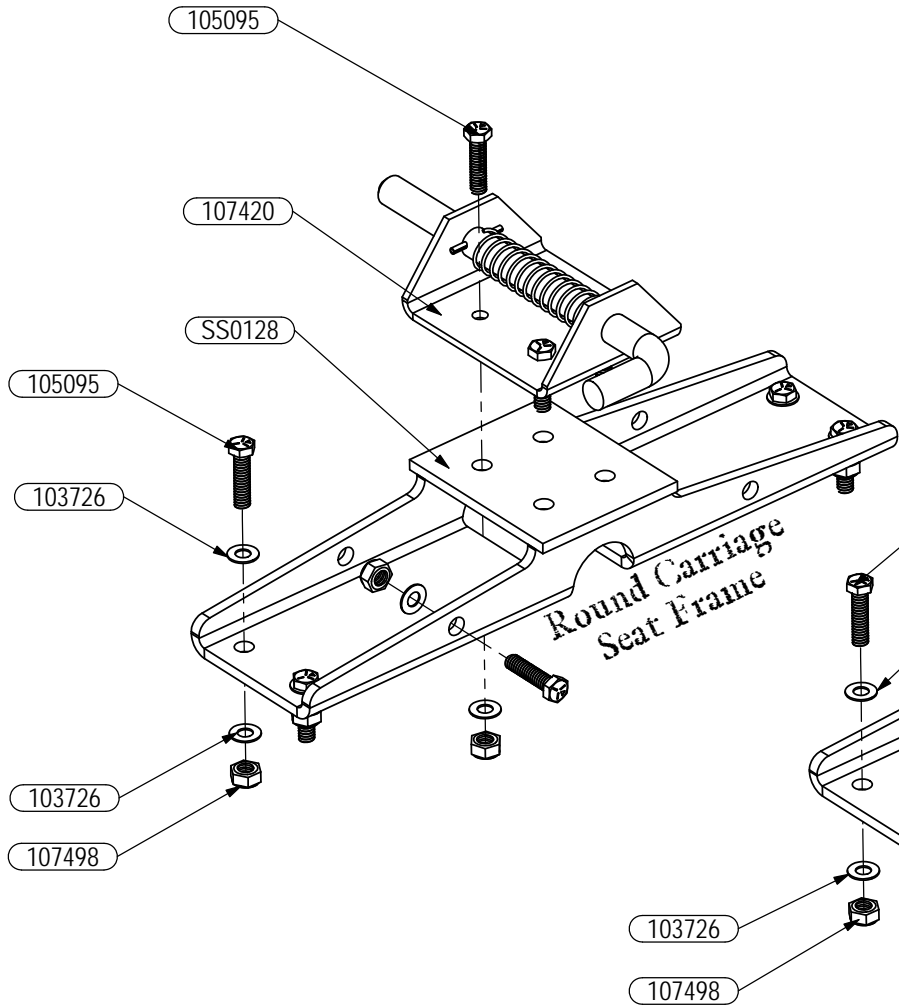

PRODUCTION MODELS	QTY	MASS	A.R.M. (US), INC. WINTERSVILLE, OH 43953 PROPRIETARY & CONFIDENTIAL
PRODUCTION MODELS	0	lb	
PRODUCTION MODELS	QTY	SCALE	C:\Data\Solids\Super Shot 200\ PART NUMBER
PRODUCTION MODELS	0	1:3	
PRODUCTION MODELS	QTY	FILE LOCATION	PAGE
PRODUCTION MODELS	0	C:\Data\Solids\Super Shot 200\ PART NUMBER	1 of 5
CREATED	MODELER	PRINTED	MATERIAL/DESCRIPTION
8/4/2016	D Macek	8/26/2016	Seat Latch Kit

Drill Template - Round Carriage Frame

PART NUMBER	DESCRIPTION	QTY.
107424	Plate - 1/4" A36	1
101397	Bolt - 1/2"-13 X 1-1/2" Hex GR5 Zinc	2
103706	Nut - 1/2"-13 Hex GR 5 Zinc	2

Drill Template - Square Carriage Frame

PART NUMBER	DESCRIPTION	QTY.
107477	Plate - 1/4" A36	1

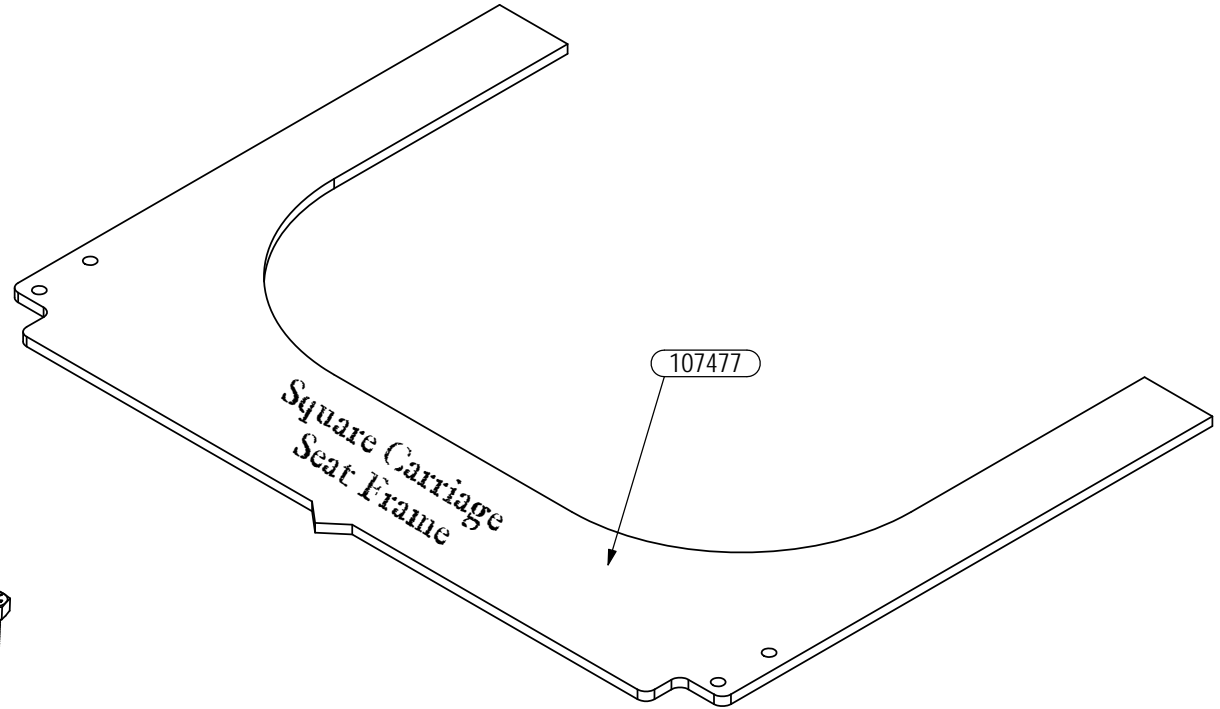
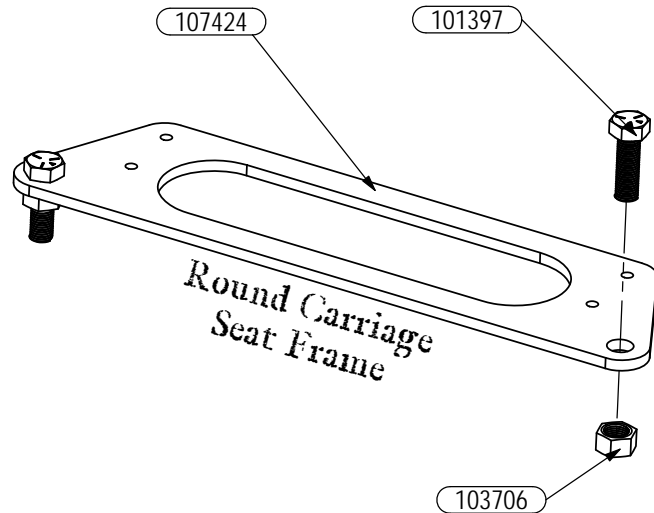

PRODUCTION MODELS	QTY	MASS	A.R.M. (US), INC. WINTERSVILLE, OH 43953 <i>PROPRIETARY & CONFIDENTIAL</i>
PRODUCTION MODELS	0	SCALE 1:4	
PRODUCTION MODELS	QTY	FILE LOCATION	PAGE
PRODUCTION MODELS	0	C:\Data\Solids\Super Shot 200\	2 of 5
PRODUCTION MODELS	QTY	SIZE	PART NUMBER
CREATED	MODELER	PRINTED	MATERIAL/DESCRIPTION
8/11/2016	D Macek	8/26/2016	Seat Latch Install Guide Seat Lock Drill Template

Round Carriage Frames Only...

- Remove Threaded Stud Supporting Electrical Wires.
- Grind Flush And Apply Primer/Paint

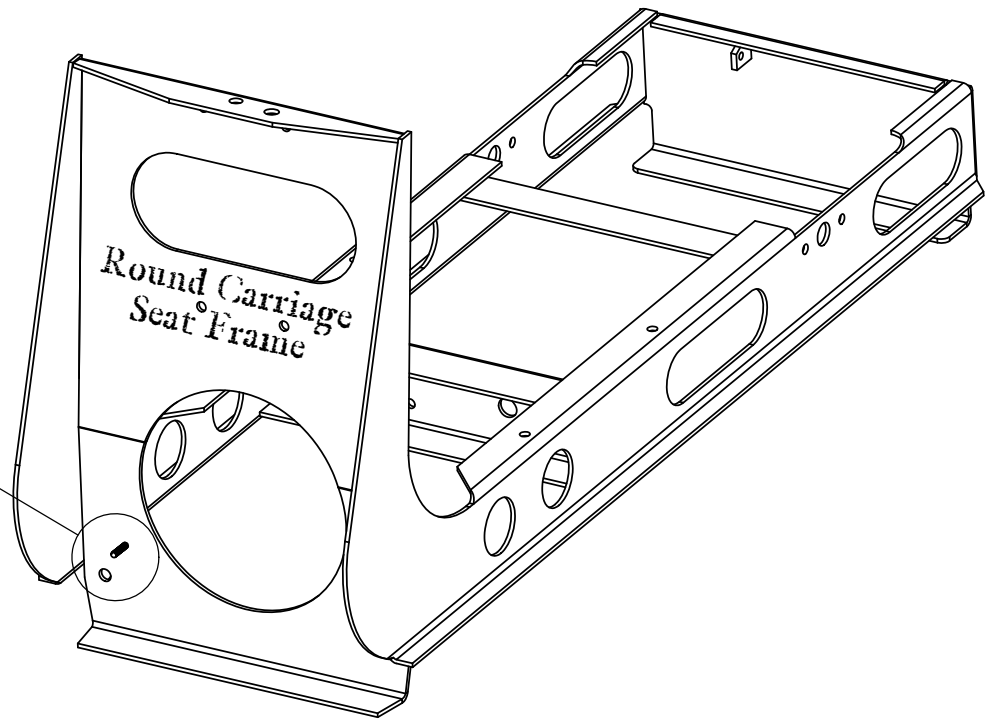
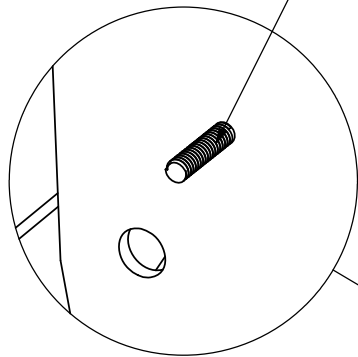

PRODUCTION MODELS	QTY	MASS	A.R.M. (US), INC. WINTERSVILLE, OH 43953	
PRODUCTION MODELS	QTY	SCALE	PROPRIETARY & CONFIDENTIAL	
PRODUCTION MODELS	QTY	FILE LOCATION	PAGE	
PRODUCTION MODELS	0	C:\Data\Solids\Super Shot 200\Seat Lock Modification\Instal Models\	3 of 5	
PRODUCTION MODELS	QTY	SIZE	PART NUMBER	REV
CREATED	MODELER	PRINTED	MATERIAL/DESCRIPTION	
1/27/2013	D Macek	8/26/2016	Seat Latch Install Guide Weldment - SS Seat Frame	

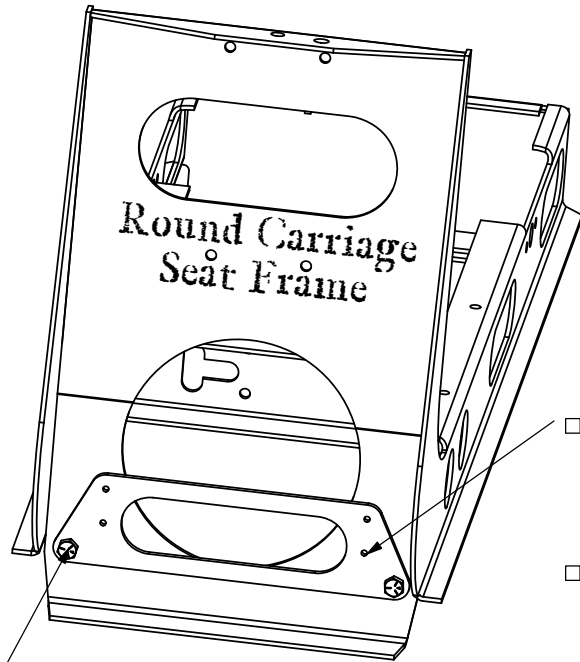

□ Bolt Drilling Template In Place Using Existing Seat Bolt Holes.

□ Drill (4) 5/16" Holes In Seat Frame

□ Drill (4) 5/16" Holes In Seat Frame

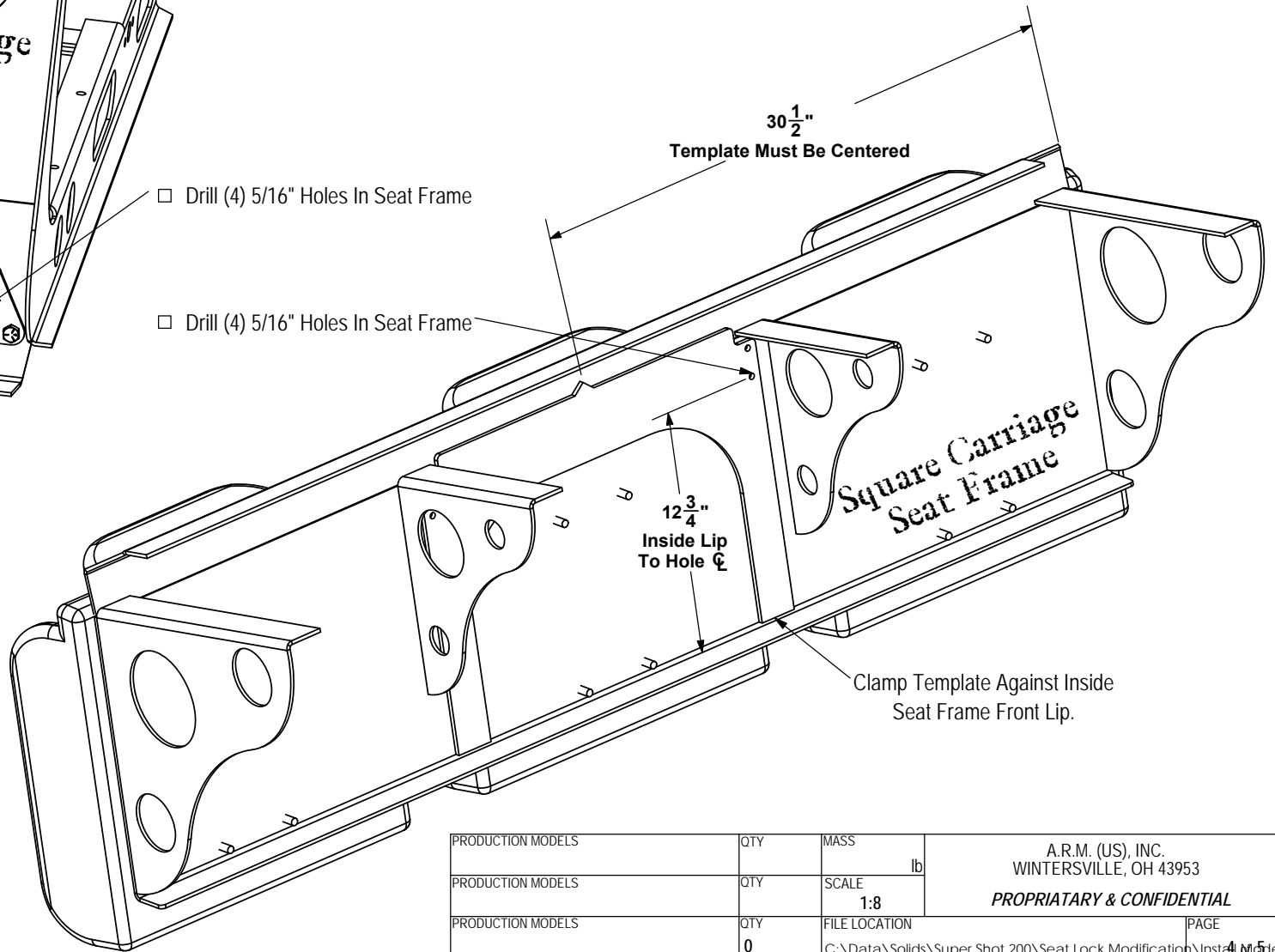

30 ¹/₂"
Template Must Be Centered

12 ³/₄"
Inside Lip To Hole ϕ

Clamp Template Against Inside Seat Frame Front Lip.

PRODUCTION MODELS	QTY	MASS	A.R.M. (US), INC. WINTERSVILLE, OH 43953 PROPRIETARY & CONFIDENTIAL
PRODUCTION MODELS	QTY	SCALE	
PRODUCTION MODELS	QTY	FILE LOCATION	PAGE
PRODUCTION MODELS	QTY	SIZE	REV
CREATED	MODELER	PRINTED	MATERIAL/DESCRIPTION
1/27/2013	D Macek	8/26/2016	Seat Latch Install Guide

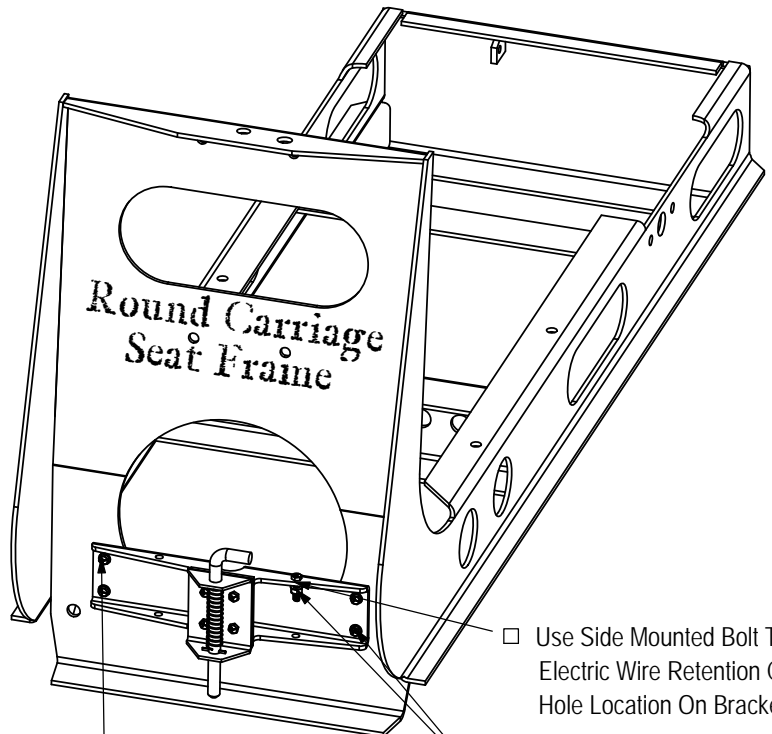

Round Carriage
Seat Frame

- Use Side Mounted Bolt To Reattach Electric Wire Retention Clip. Use Suitable Hole Location On Bracket.
- Torque 1/4" GR5 Bolts To 6.3 Ft Lbs.

Bolt Latch Assembly To Frame Using Newly Drilled Holes.

- Bolt Latch Assembly To Frame Using Newly Drilled Holes.
- Torque 1/4" GR5 Bolts To 6.3 Ft Lbs/

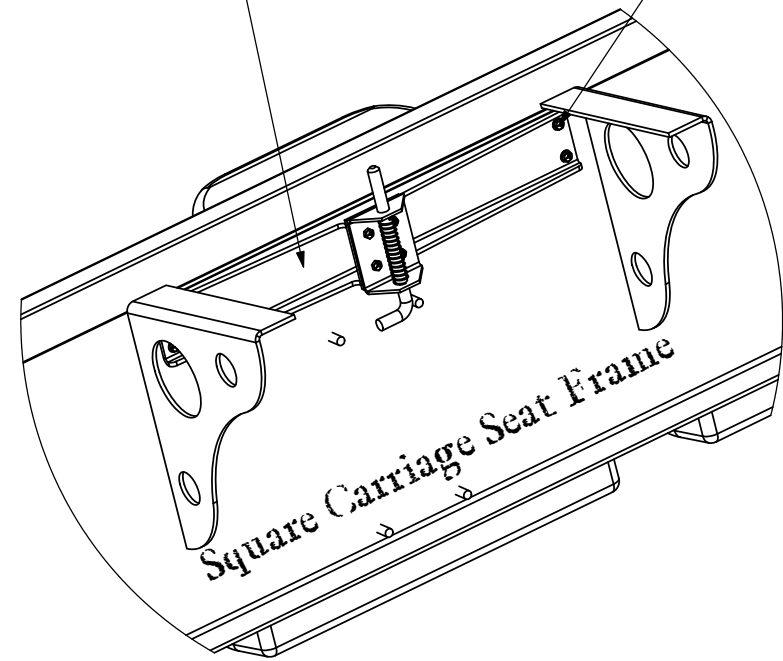

Square Carriage Seat Frame

PRODUCTION MODELS	QTY	MASS	A.R.M. (US), INC. WINTERSVILLE, OH 43953	
PRODUCTION MODELS	QTY	SCALE	PROPRIETARY & CONFIDENTIAL	
PRODUCTION MODELS	QTY	FILE LOCATION	PAGE	
PRODUCTION MODELS	QTY	SIZE	REV	
PRODUCTION MODELS	QTY	PART NUMBER	REV	
CREATED	MODELER	PRINTED	MATERIAL/DESCRIPTION	
1/27/2013	D Macek	8/26/2016	Seat Latch Install Guide	