



Number: B108R1019-0

Date: Nov. 18, 1987

SERVICE BULLETIN

Effective Serial Numbers: See Text

Ride: SKY DIVER & ASTRO WHEEL

Subject: Outrigger Support
Brace Rework

CHANCE RIDES, INC. has developed a rigid brace to replace the existing bar and turnbuckle brace on the new style outrigger supports on SKY DIVERS and ASTRO WHEELS. This rigid brace will further increase the stability of the outriggers.

NOTE: If your ride does not have the new style outrigger supports, this bulletin does not apply and can be disregarded.

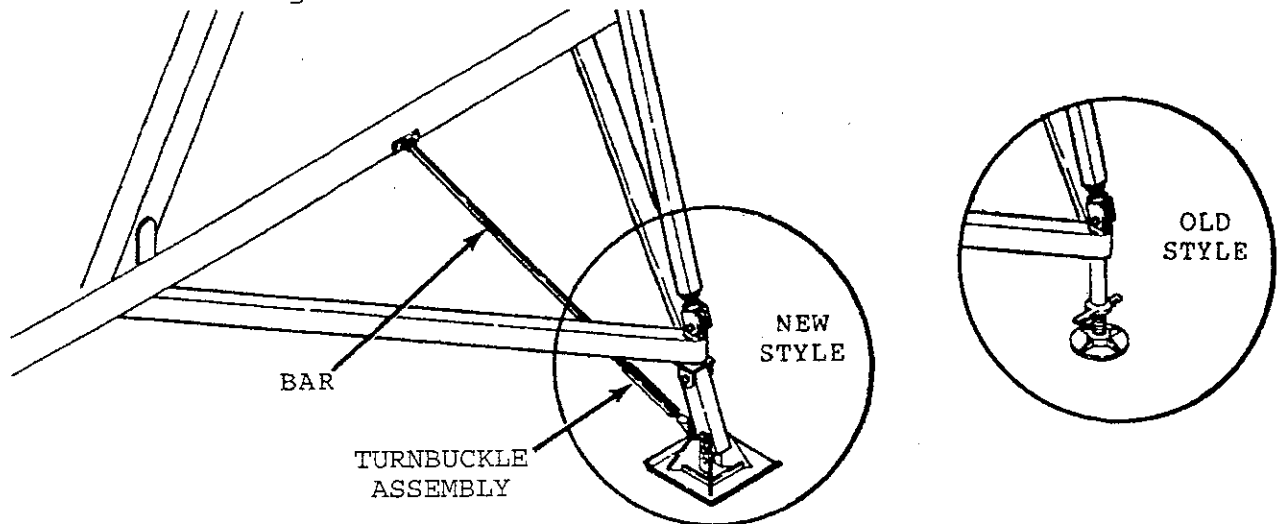

CHANCE RIDES, INC. requires that owners of all SKY DIVER and ASTRO WHEEL amusement rides with new style outrigger supports, perform the rework described in this bulletin. Use the instructions on the reverse side of this bulletin and the parts provided. Return the Certification Of Compliance within fifteen (15) days from receipt of this bulletin.

All work must be performed by competent, qualified mechanics, capable of understanding the function of the parts and their proper installation. If there are any questions regarding the instructions or this rework, contact the CHANCE CUSTOMER SERVICE DEPARTMENT.

INSTALLATION INSTRUCTIONS

Locate and weld the pear links on each tower leg as shown in the following illustration. All work must be performed by competent, qualified mechanics, capable of understanding the function of the parts and their proper installation.

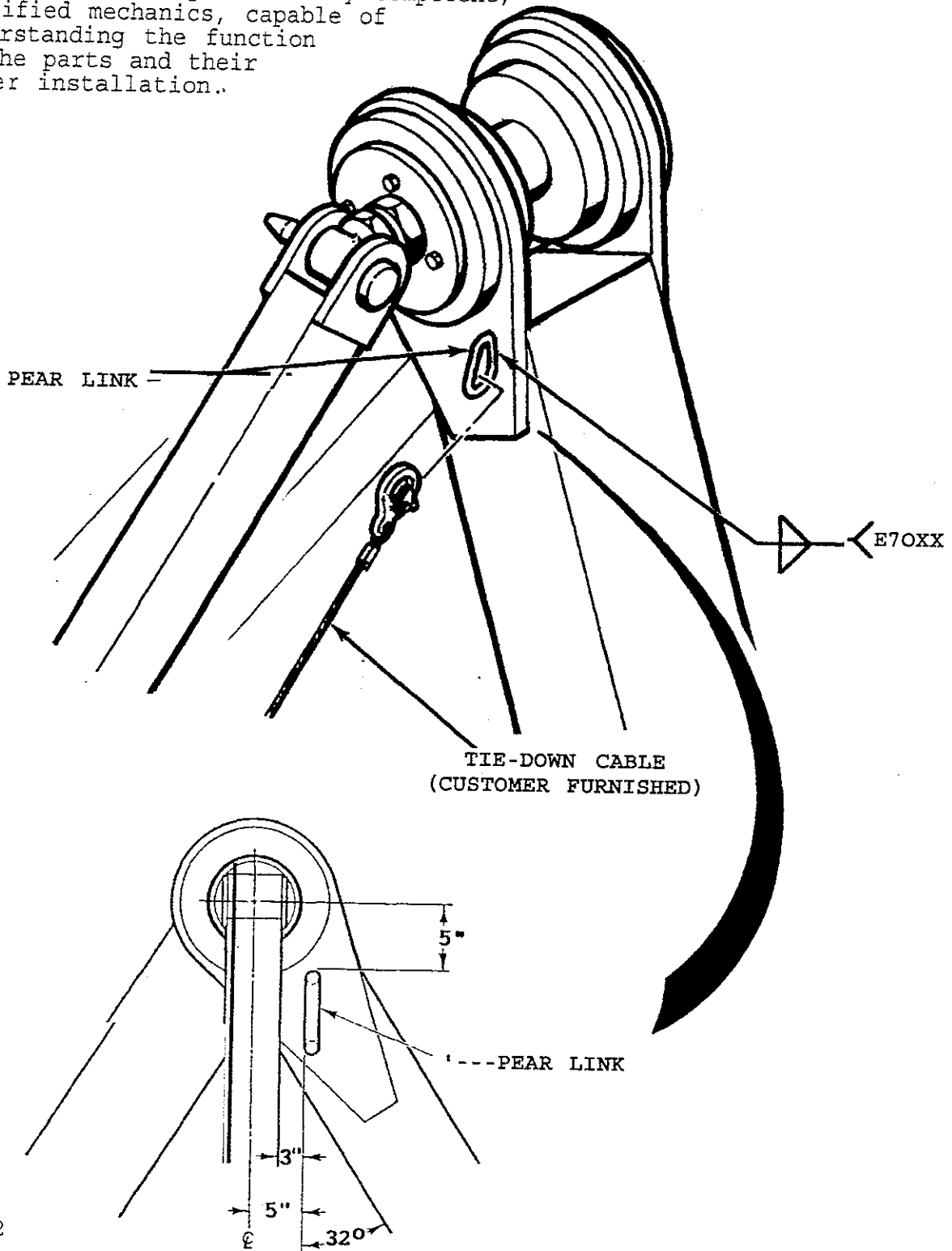

BLOCKING PROCEDURE

Always perform the following procedure before operating the ride.

1. Inspect the blocking under each of the four trailer leveling jacks, the four screw jacks and the two outrigger jacks. Good, solid blocking, preferably wooden 3 x 12's, must be placed under each jack point. As blocks are stacked, criss-cross each layer, ending the stack with a single block as shown in the following illustrations.

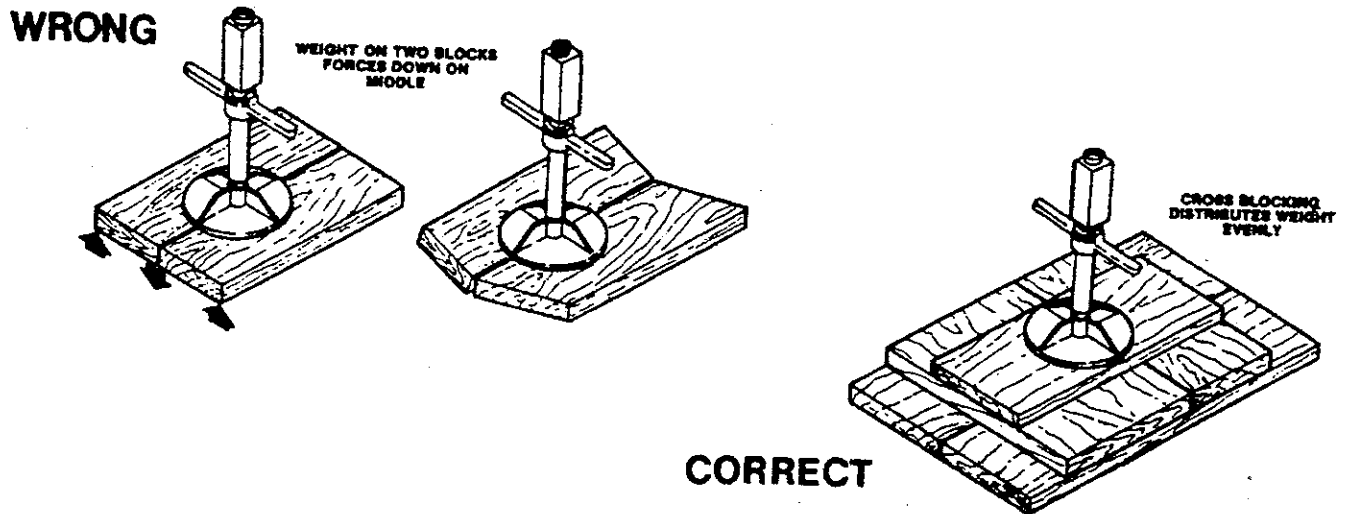

2. Make sure the lock rings on the leveling jacks are tight up against the bottom of the jack. All needle valves and the hand pump valve must be OPEN to relieve hydraulic pressure in the leveling jacks. This is important, because hydraulic oil in the jacks can expand when exposed to heat, such as direct sunlight, causing the jack to extend.

3. The outrigger jacks must be extended down against the blocking until snug. DO NOT OVER-TIGHTEN THE OUTRIGGER JACKS TO AVOID A PRE-LOADING CONDITION IN THE OUTRIGGERS.

TIE-DOWN PROCEDURE

WARNING: DUE TO UNPREDICTABLE CONDITIONS GENERATED BY HIGH WINDS, SUCH AS MICRO-BURSTS, THE MANUFACTURER CANNOT GUARANTEE THE STABILITY OF THE RIDE IN HIGH WINDS. ALWAYS OBSERVE THE FOLLOWING PRECAUTIONS TO HELP PREVENT DAMAGE TO EQUIPMENT, AND INJURIES TO PASSENGERS AND/OR BYSTANDERS:

- NEVER OPERATE THE RIDE WITH PASSENGERS IN WINDS EXCEEDING 35 MPH.
- IT IS RECOMMENDED THAT THE RIDE BE TIED DOWN AS DESCRIBED IN THIS BULLETIN IF WINDS OVER 50 MPH ARE ANTICIPATED.
- TIE-DOWNS ARE REQUIRED TO ASSIST IN STABILIZING THE RIDE DURING HIGH WINDS.

When high wind conditions are anticipated, use the following procedure to tie-down the ride. Use 1/2" Extra Improved Plow Steel Cable.

1. Attach cables to the pear links on the tower legs. Attach the other end of each cable to anchors capable of withstanding a 6,000 pound line pull in the specified cable. (See illustration on next page).
2. Tighten the cables until snug.

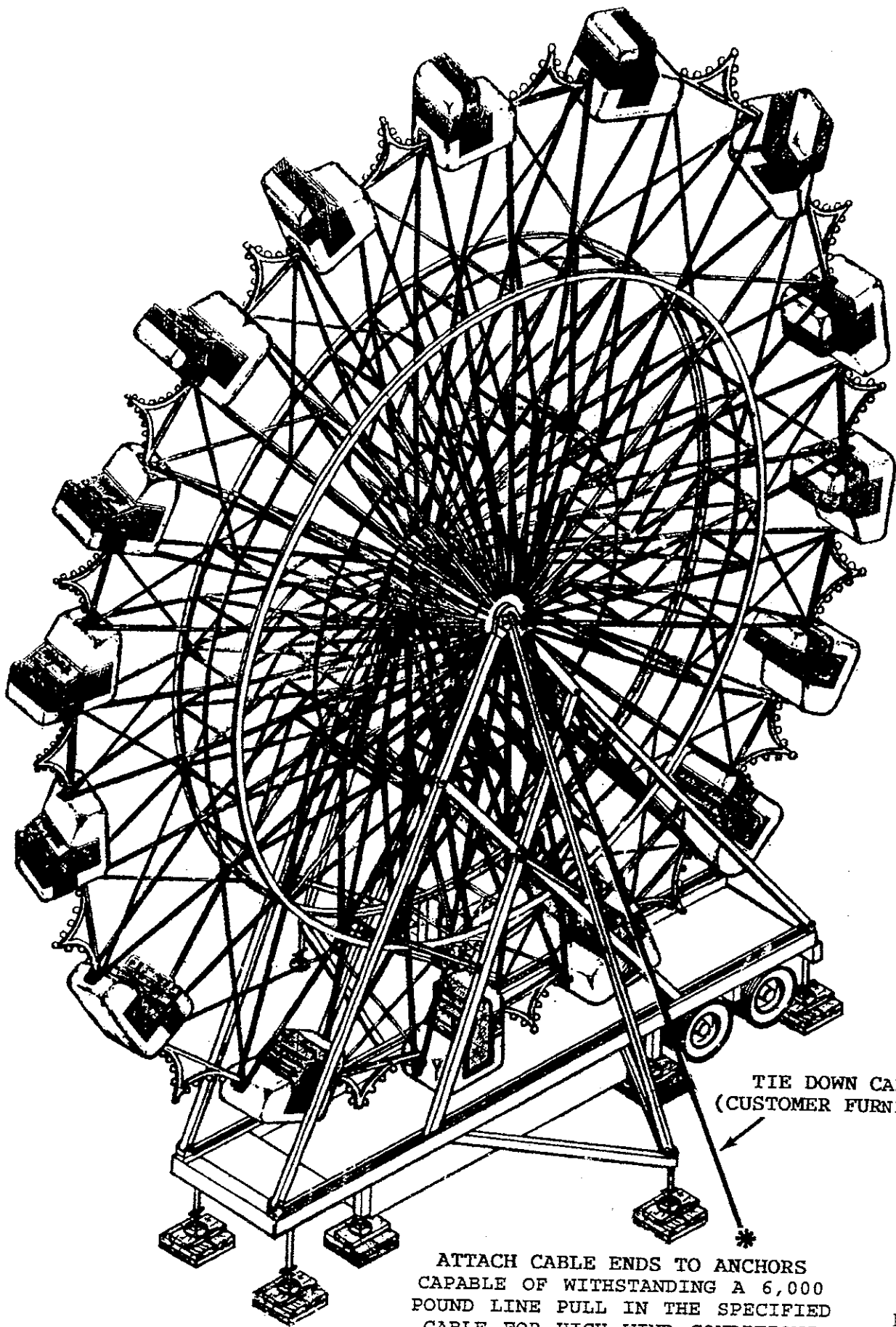

TIE DOWN CABLE
(CUSTOMER FURNISHED)

ATTACH CABLE ENDS TO ANCHORS
CAPABLE OF WITHSTANDING A 6,000
POUND LINE PULL IN THE SPECIFIED
CABLE FOR HIGH WIND CONDITIONS