



Number: A392R1004-0

Date: June 30, 1986

Supersedes:

America's Largest Manufacturer of Amusement Rides

---

---

# SAFETY ALERT

---

---

Effective Serial Numbers: All Units

Ride: THUNDERBOLT

Subject: Inspection and Adjustment  
Of Spreader Bars



**WARNING: FAILURE TO COMPLY WITH THIS SAFETY ALERT BULLETIN  
CAN RESULT IN INJURY TO PASSENGERS.**

CHANCE RIDES, INC. has determined, by observation in the field, that the spreader bars on several rides are not correctly adjusted. The proper operation of the spreader bars is essential on THUNDERBOLT amusement rides. Worn, damaged or improperly adjusted spreader bars can cause damage to the sweeps, spreader bars and center hub, and cause rough operation, which can result in injury to passengers.

READ THESE INSTRUCTIONS THOROUGHLY AND BECOME FAMILIAR WITH THE ENTIRE PROCEDURE. All work must be performed by competent, qualified mechanics, capable of understanding the function of the parts and their proper installation.

Complete the spreader bar inspection and adjustment procedure using the instructions provided on the following pages of this bulletin. Fill out and return the attached Certification of Compliance for the procedure within fifteen (15) days from receipt of this bulletin.

## INSPECTION OF SPREADER BARS

Before adjusting the spreader bars, inspect all spreader bars for cracks or bends as described in the Thunderbolt Operation Manual (part no. 276-43268). For convenience, the inspection points are described below

Inspect for cracks in the areas indicated by arrows in the following illustration. Also check the spreader bar mounting points for worn bushings or pins. If wear or damage is found in any of these areas, contact the CHANCE CUSTOMER SERVICE DEPARTMENT immediately.

DO NOT OPERATE THE RIDE WITH QUESTIONABLE SPREADER BARS.

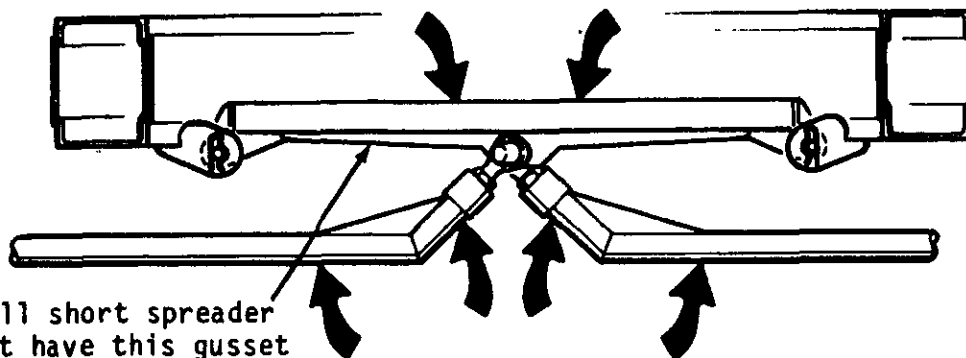

NOTE: All short spreader bars must have this gusset

**IMPORTANT:** Do not attempt to repair spreader bars in the field. Any spreader bar which has been welded, drilled or otherwise repaired must be discarded and replaced with a new part.

## SPREADER BAR ADJUSTMENT PROCEDURE

1. Remove all long spreader bars.
2. Loosen ALL jam nuts and set screws.

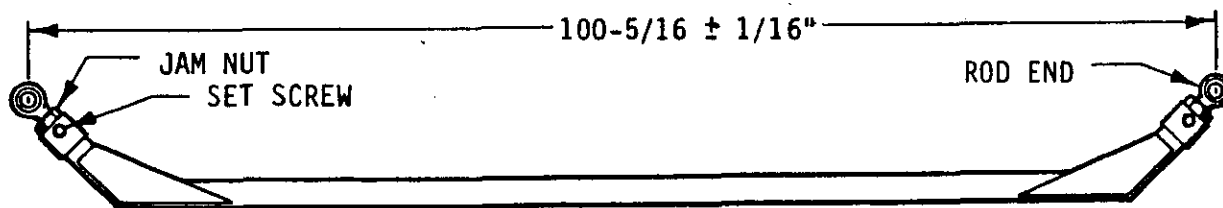

3. Measure the length between the rod ends, center to center, on all long spreader bars. This measurement must be  $100-5/16 \pm 1/16$  inches. Adjust the length by turning the rod ends.

**IMPORTANT:** Both rod ends must be threaded into the sockets an equal number of turns. Always adjust both rod ends equally, within one-half turn.

4. Install the long spreader bars on the ride. Install all cars.

5. Remove one end of the long spreader bar which is 180° from the master sweep (driving sweep).
6. Rotate the ride counterclockwise one complete revolution by hand using two or three men.

NOTE: Open the hand valve on the hydraulic motor for ease of turning.

As the ride turns, measure the distance the disconnected rod end travels in relation to the pin on the short spreader bar. This distance of travel must be the same each direction from the pin.

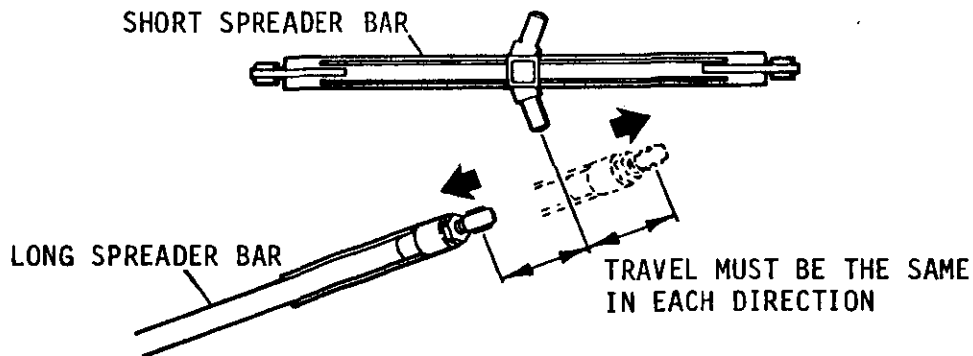

7. If the travel is equal in both directions, install the spreader bar and tighten all jam nuts and set screws.

If the travel is not equal in both directions, adjust the length of each long spreader bar (either longer or shorter) by turning the rod ends. ALL SPREADER BARS MUST BE THE SAME LENGTH. If one spreader bar is adjusted to a longer length, ALL spreader must be lengthened by the same amount.

Repeat STEPS 6 and 7 until the travel is equal.

8. Permanently mark all sweeps so that they can be installed in the same location every time the ride is set up.
9. Check spreader bar adjustment every time the ride is set up.

APR 55 2 08 PM '00  
 WTDOT  
 COMPLIANCE  
 2VELEA



# Certification of Compliance

SERVICE BULLETIN A392R1004-0

(6-30-86)

We hereby certify the procedure outlined in the above-mentioned service bulletin has been performed on the THUNDERBOLT

Serial No(s) \_\_\_\_\_, in accordance with the instructions and specifications supplied by Chance Rides, Inc.

Date Bulletin Received \_\_\_\_\_

Date Procedure Performed \_\_\_\_\_

Name and Address of Person performing Procedure:

\_\_\_\_\_  
\_\_\_\_\_

**Attested:**

Owner \_\_\_\_\_

Maintenance Supervisor \_\_\_\_\_

Address \_\_\_\_\_

Address \_\_\_\_\_

City \_\_\_\_\_ State \_\_\_\_\_

City \_\_\_\_\_ State \_\_\_\_\_

By: \_\_\_\_\_

Date: \_\_\_\_\_

Date: \_\_\_\_\_

**Results:** \_\_\_\_\_  
\_\_\_\_\_  
\_\_\_\_\_  
\_\_\_\_\_

This certification must be completed and returned to Chance Rides, Inc. within fifteen (15) days of receipt of the bulletin.

10255 A 22 01.02  
COMPLIANCE  
20611A



*(MUSIC FEST  
Arco Shows  
REITHOFFER  
THUNDERBOLT)*

Number A37-0288-00

Date 9-15-86

Supersedes:

America's Largest Manufacturer of Amusement Rides

# SAFETY ALERT

Effective Serial Numbers: See Text

Ride: THUNDERBOLT / MUSIC FEST

Subject: Spreader Bar Rework Kit

 **WARNING: FAILURE TO COMPLY WITH THIS SAFETY ALERT BULLETIN CAN RESULT IN INJURY TO PASSENGERS.**

The long spreader bars on the following THUNDERBOLT and MUSIC FEST amusement rides incorporate a solid steel rod through the center:

- THUNDERBOLT Serial Nos. 85-53001 through 85-53007
- MUSIC FEST Serial No. 85-27066 only

If a spreader bar breaks because of wear, damage or improper adjustment, this rod provides support to the spreader bar until the ride can be brought to a complete stop.

CHANCE MANUFACTURING CO., INC. has become aware of at least one incident in which a support rod broke and came out of the spreader bar, causing damage to the ride.

CHANCE has developed an improvement to this feature by replacing the steel rods with flexible steel cables. Owners of the above noted rides are required to install the modification kit on all the long spreader bars.

Read the following instructions thoroughly and become familiar with the entire procedure. All work must be performed by competent, qualified mechanics, capable of understanding the function of the parts and their proper installation.

Complete the installation using the instructions provided on the following page of this bulletin. Fill out and return the attached Certification of Compliance within (15) days from the receipt of the kit.

PARTS LIST - Kit K37-0288-00 (Part No. 337-38755)

<u>Ref. No.</u>	<u>Description</u>	<u>Qty. Reqd.</u>
1.	"Safety Alert" Bulletin A37-0288-00 .....	1
2.	Installation Tube (Dwg. No. K37-0288-01)...	1
3.	Cable (Dwg. No. K37-0288-02).....	9
	Cable Clamp (Part No. 290-16108).....	18

Factory and Sales Office: 4219 Irving • P.O. Box 12328 • Wichita, Kansas 67277 • (316) 942-7411

# Installation Instructions

1. Remove one long spreader bar.
2. Remove the nut from one end of the support rod. Remove and discard the rod.

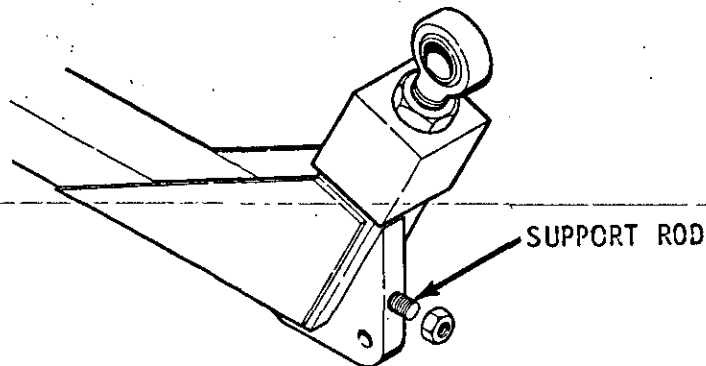

3. Insert the installation tube provided through the holes in the spreader bar. Insert the cable through the installation tube. Attach a cable clamp approximately 1 to 1-1/2 inch from one end of the cable. Tighten the nuts securely.

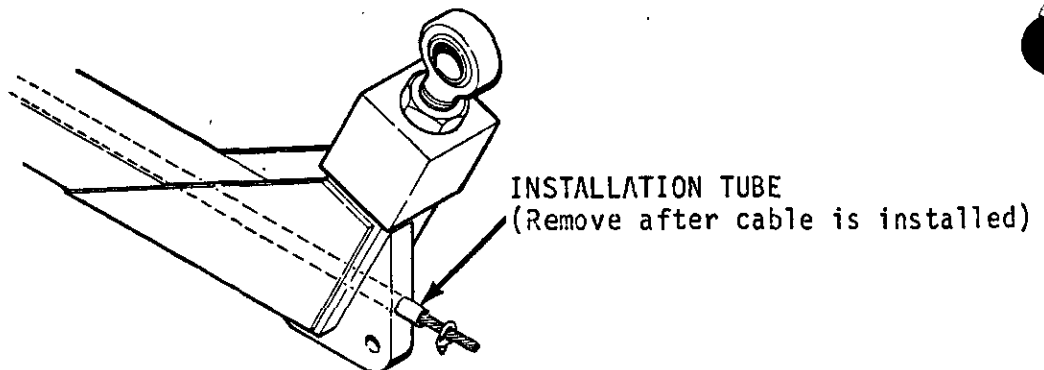

4. Remove the installation tube. Pull the cable tight by hand and install a cable clamp to allow approximately 1/8 inch clearance to the spreader bar.

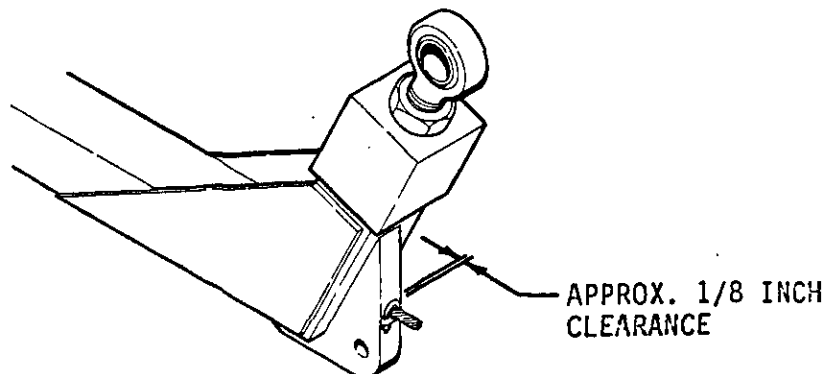

5. Install the reworked spreader bar. Repeat the procedure for all remaining long spreader bars.



# Certification of Compliance

SERVICE BULLETIN A37-0288-00

We hereby certify the procedure outlined in the above-mentioned service bulletin has been performed on the THUNDERBOLT / MUSIC FEST

Serial No(s) \_\_\_\_\_, in accordance with the instructions and specifications supplied by Chance Manufacturing Company, Inc.

Date Bulletin Received \_\_\_\_\_

Date Procedure Performed \_\_\_\_\_

Name and Address of Person performing Procedure:

\_\_\_\_\_  
\_\_\_\_\_

**Attested:**

Owner \_\_\_\_\_

Maintenance Supervisor \_\_\_\_\_

Address \_\_\_\_\_

Address \_\_\_\_\_

City \_\_\_\_\_ State \_\_\_\_\_

City \_\_\_\_\_ State \_\_\_\_\_

By: \_\_\_\_\_

Date: \_\_\_\_\_

Date: \_\_\_\_\_

Results: \_\_\_\_\_  
\_\_\_\_\_  
\_\_\_\_\_  
\_\_\_\_\_

This certification must be completed and returned to Chance Manufacturing Company, Inc. within fifteen (15) days of receipt of the bulletin



~~Handwritten~~  
FEITWOLLER  
THUNDERBOLT.

Number: A392R1005-0

Date: 9-15-86

Supersedes:

America's Largest Manufacturer of Amusement Rides

# SAFETY ALERT

Effective Serial Numbers: 86-53008, 392-009-86 & 392-010-86

Ride: THUNDERBOLT

Subject: Spreader Bar Rework Kit

 **WARNING: FAILURE TO COMPLY WITH THIS SAFETY ALERT BULLETIN CAN RESULT IN INJURY TO PASSENGERS.**

The long spreader bars on the THUNDERBOLT amusement rides noted above incorporate a solid steel rod through the center. If a spreader bar breaks because of wear, damage or improper adjustment, this rod provides support to the spreader bar until the ride can be brought to a complete stop.

Chance Rides, Inc. has become aware of at least one incident in which a support rod broke and came out of the spreader bar, causing damage to the ride.

CHANCE has developed an improvement to this feature by replacing the steel rods with flexible steel cables. Owners of the above noted rides are required to install the modification kit on all long spreader bars.

Read the instructions thoroughly and become familiar with the entire procedure. All work must be performed by a competent, qualified mechanics, capable of understanding the function of the parts and their proper installation.

Complete the installation using the instructions provided on the following page of this bulletin. Fill out and return the attached Certification Of Compliance within (15) days from receipt of this bulletin.

### PARTS LIST - Kit K37-0288-00 (Part No. 337-38755)

<u>Ref. No.</u>	<u>Description</u>	<u>Qty. Reqd.</u>
1.	"Safety Alert" Bulletin A37-0288-00 .....	1
2.	Installation Tube (Dwg. No. K37-0288-01)...	1
2.	Cable (Dwg. No. K37-0288-02).....	9
3.	Cable Clamp (Part No. 290-16108).....	18



# Installation Instructions

1. Remove one long spreader bar.
2. Remove the nut from one end of the support rod. Remove and discard the rod.

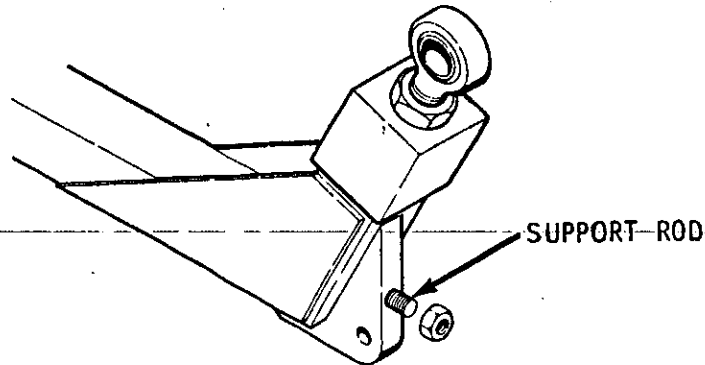

3. Insert the installation tube provided through the holes in the spreader bar. Insert the cable through the installation tube. Attach a cable clamp approximately 1 to 1-1/2 inch from one end of the cable. Tighten the nuts securely.

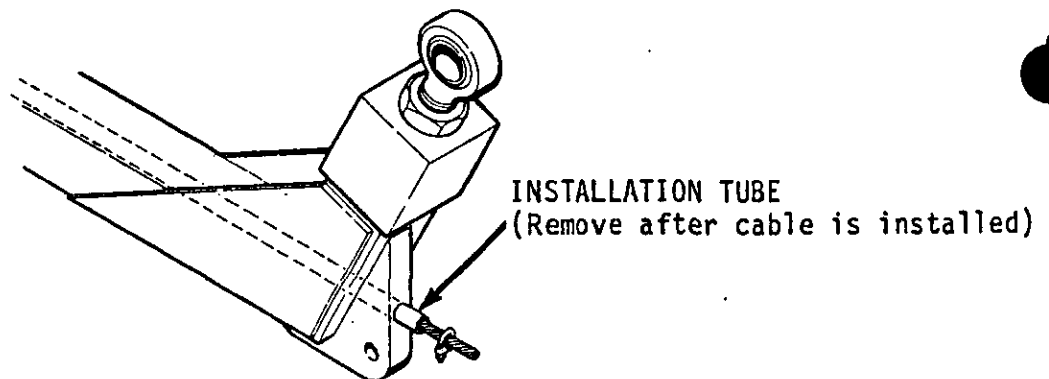

4. Remove the installation tube. Pull the cable tight by hand and install a cable clamp to allow approximately 1/8 inch clearance to the spreader bar.

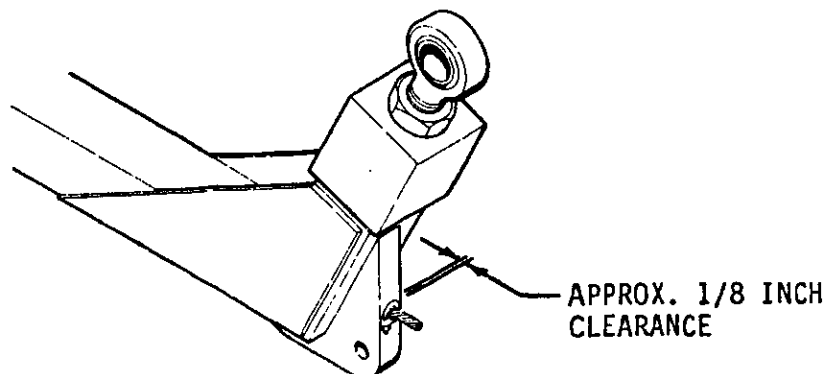

5. Install the reworked spreader bar. Repeat the procedure for all remaining long spreader bars.



## Certification of Compliance

SERVICE BULLETIN A392R1005-0

We hereby certify the procedure outlined in the above-mentioned service bulletin has been performed on the THUNDERBOLT

Serial No(s) \_\_\_\_\_, in accordance with the instructions and specifications supplied by Chance Rides, Inc.

Date Bulletin Received \_\_\_\_\_

Date Procedure Performed \_\_\_\_\_

Name and Address of Person performing Procedure:

\_\_\_\_\_  
\_\_\_\_\_

**Attested:**

Owner \_\_\_\_\_

Maintenance Supervisor \_\_\_\_\_

Address \_\_\_\_\_

Address \_\_\_\_\_

City \_\_\_\_\_ State \_\_\_\_\_

City \_\_\_\_\_ State \_\_\_\_\_

By: \_\_\_\_\_

Date: \_\_\_\_\_

Date: \_\_\_\_\_

**Results:** \_\_\_\_\_  
\_\_\_\_\_  
\_\_\_\_\_  
\_\_\_\_\_

This certification must be completed and returned to Chance Rides, Inc. within fifteen (15) days of receipt of the bulletin.



Number: B392R1010-0

Date: June 30, 1987

Supersedes:

---

---

## SERVICE BULLETIN

---

---

Effective Serial Numbers: 392-008-86 through 392-014-86

Ride: THUNDERBOLT

Subject: Auxilliary Trailer  
Rack Rework

CHANCE RIDES, INC. recommends that the following rework be performed on THUNDERBOLT amusement rides with the above noted serial numbers. The rework reinforces the vertical members of the vehicle racks for added rigidity.

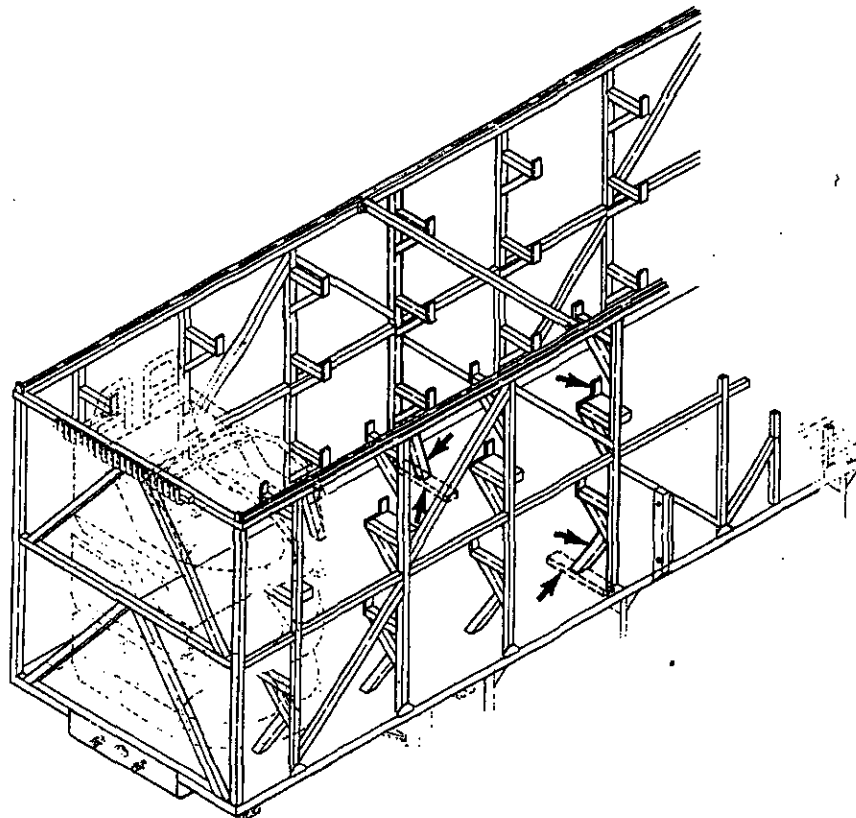

Order kit number K76-0300-00, which includes all parts necessary for one complete ride. Install the kit using the instructions provided on the reverse side of this bulletin.

## INSTALLATION INSTRUCTIONS

All work must be performed by a certified welder, capable of understanding the function of the parts and their proper installation.

Read these instructions thoroughly and make sure you understand them before installing the kit. Identify all parts by checking them against the parts list. If any parts are missing, notify the CHANCE CUSTOMER SERVICE DEPARTMENT.

1. Locate and weld the floor braces (Item #3) as shown.
2. Locate and weld the angle braces (Items #1 and #2) as shown. Pay particular attention to the different height angle braces for each side of the trailer.
3. Cut the ears flush with the tubes on the existing vehicle hangers as shown. DO THIS ONLY ON THE MIDDLE ROW OF HANGERS ON THE ROADSIDE WALL OF THE TRAILER.
4. Locate and weld the offset vehicle hangers (Item #4).

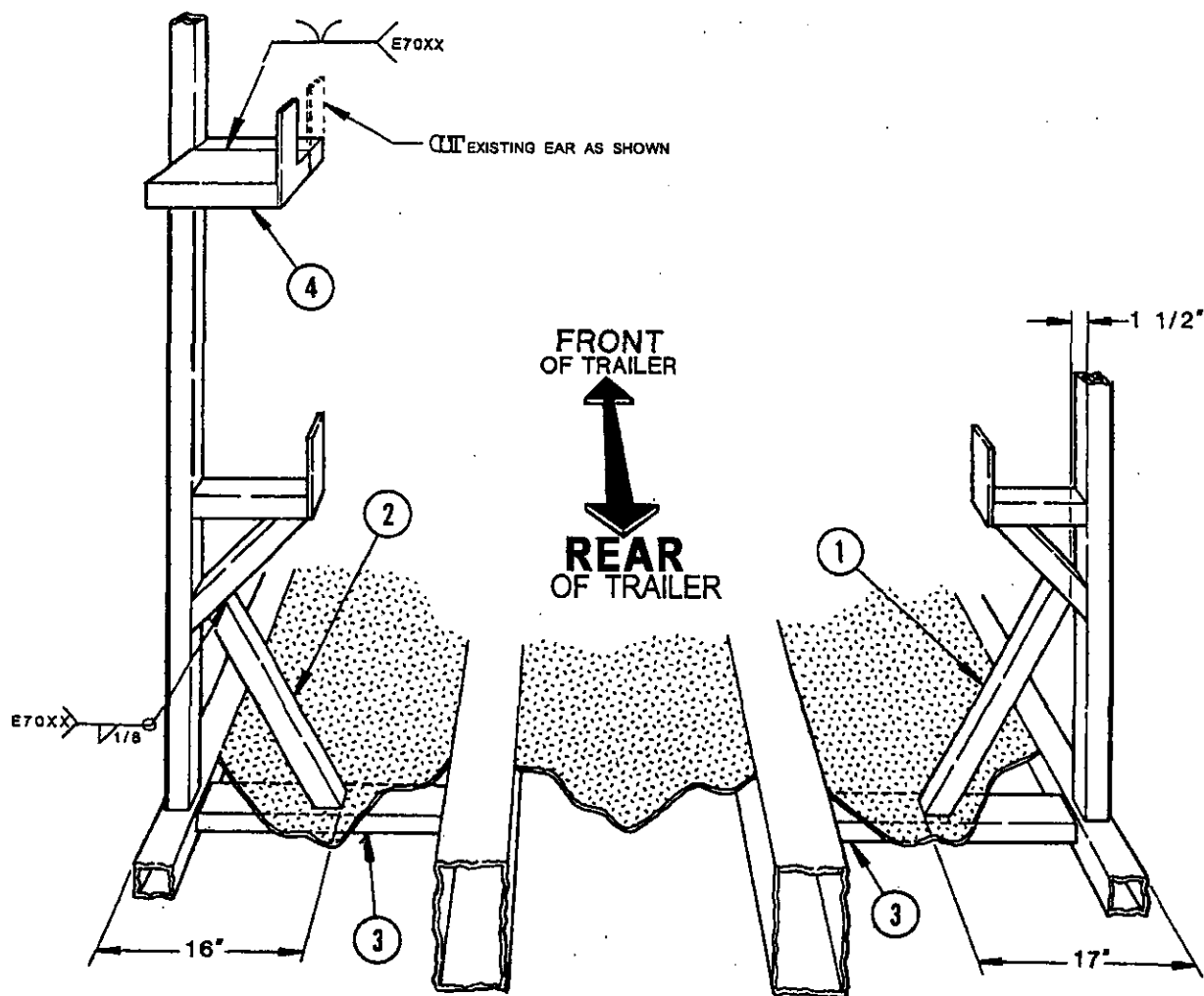

### PARTS LIST

Kit Number K76-0300-00 ~~Auxiliary~~ Trailer Rack Rework

Item No.	Quantity	Part Number	Description
2	6	376-09215	ANGLE BRACE - 25-3/16 Lg. (392-517-048)
3	12	376-09216	ANGLE BRACE - 19-5/8 Lg. (392-517-049)
			FLOOR BRACE (392-516-037)
4	6	376-32750	OFFSET VEHICLE HANGER (K76-0300-01)



Number: B392R1015-0

Date: June 30, 1987

Supersedes:

---



---

# SERVICE BULLETIN

---



---

Effective Serial Numbers: 392-008-86 through 392-010-86

Ride: THUNDERBOLT

Subject: Vehicle Back Brace

A kit is now available to provide additional support in the back rest area of the vehicles on THUNDERBOLT amusement rides with the above noted serial numbers. CHANCE RIDES, INC. recommends that this kit be installed to extend the service life of the vehicle fiberglass.

Order kit number K76-0304-00, which includes all necessary parts and hardware for one complete ride. Install the kit using the instructions provided on the reverse side of this bulletin.

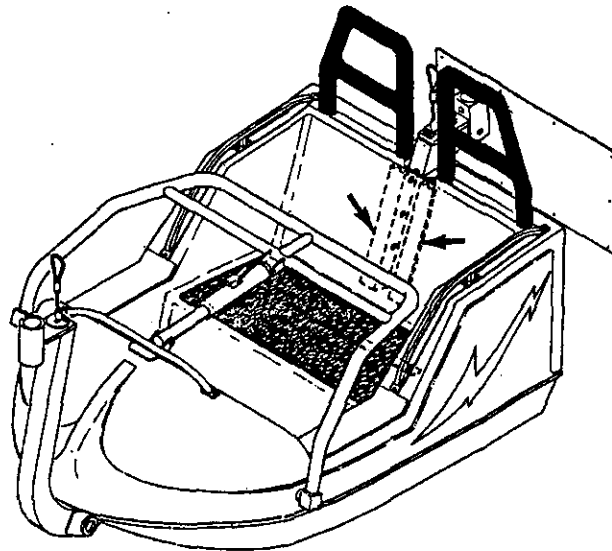

### PARTS LIST

Quantity	Part Number	Description
36	376-09094	BACK BRACE (392-111-001)
144	684-61451	POP RIVET - SC86ES

## INSTALLATION INSTRUCTIONS

All work must be performed by a competent, qualified mechanics, capable of understanding the function of the parts and their proper installation. Read these instructions thoroughly and make sure You understand them before installing the kit.

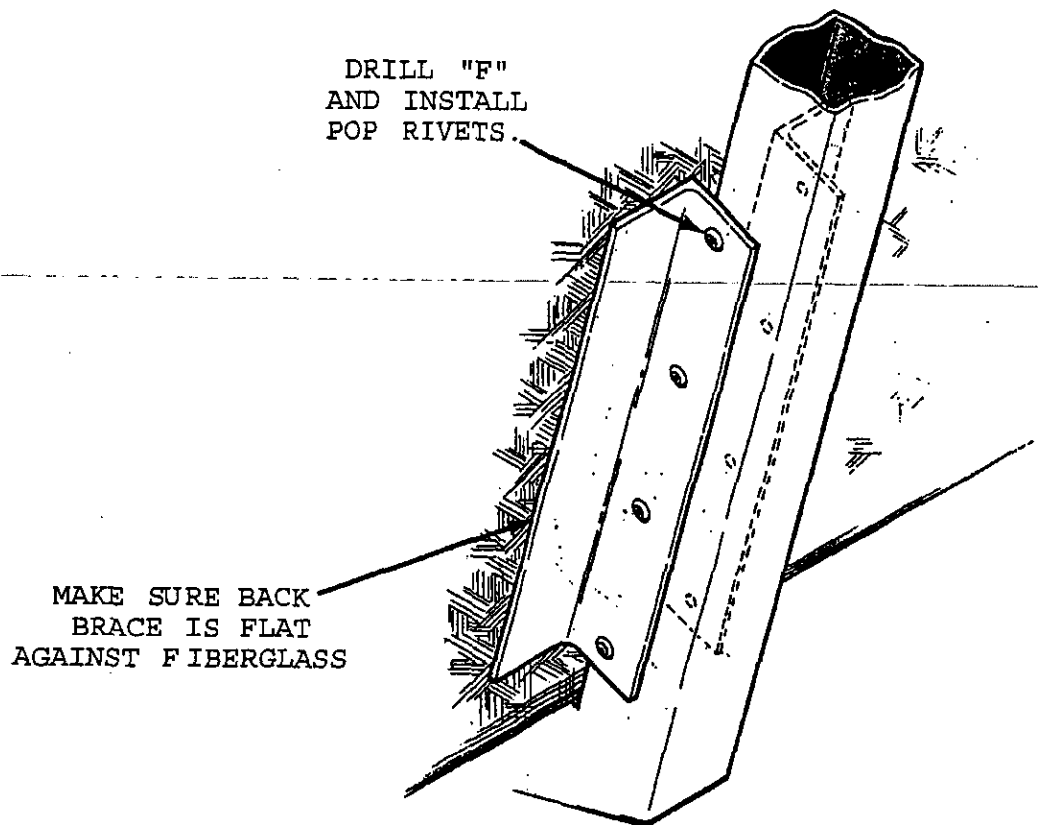

1. Remove the back panel from the vehicle.
2. Place the back brace on the vehicle frame so that it is flat against the fiberglass in the back rest area.
3. Locate and drill holes (Size "F") and install the back brace with pop rivets.
4. Use the same procedure to install the back brace on the opposite side of the vehicle frame
5. Install the back panel.
6. Repeat Steps 1 through 5 on the remaining vehicles.



Number:  
B76-0306-00  
Date:  
September 9, 1987

Supersedes:

America's Largest Manufacturer of Amusement Rides

# SERVICE BULLETIN

Effective Serial Numbers:  
85-53001 through 85-53007

Ride:  
THUNDERBOLT

Subject:  
Vehicle Frame  
Pivot Modification

As a safety precaution, CHANCE MANUFACTURING CO., INC. requires that the owners of THUNDERBOLT amusement rides with the above noted serial numbers perform the modification described in this bulletin. This modification will provide improved bearing retention in the vehicle frame pivot.

Order kit number K76-0306-00, which includes all necessary parts and hardware for one complete ride. Install the kit using the instructions provided on the reverse side of this bulletin. Fill out the attached Certification Of Compliance for the installation no later than January 1, 1988.

## PARTS LIST

Kit Number K76-0306-00 Vehicle Frame Pivot Modification

<u>Quantity</u>	<u>Part Number</u>	<u>Description</u>
36	376-04416	BEARING (392-136-001)
18	686-07531	CAPSCREW - Gr.8 (5/16-18 x 5-1/2)
18	691-48044	NUT - Lock (5/16-18)
36	696-85306	WASHER (5/16)
36	686-07662	CAPSCREW (3/8-16 x 1/2)

12-10-87  
10-10-87  
10-10-87

## INSTALLATION INSTRUCTIONS

All work must be performed by a competent, qualified mechanic, capable of understanding the function of the parts and their proper installation. Read these instructions thoroughly and make sure you understand them before installing the kit.

1. Remove all four set screws from the vehicle frame pivot.
2. Unscrew and discard the bearing on one side of the vehicle. Be sure to keep the spacer. Install the new bearing and existing spacer in the frame using green Loctite thread sealant, and tighten the bearing. Repeat the procedure on the other side of the vehicle.
3. Install the 5/16-18 x 5-1/2 cap screw, washers and nut through the new bearings as shown. Tighten the nut to 15-18 lb-ft.
4. Install 3/8-36 x 1/2 cap screws in the two set screw holes using green Loctite thread sealant, to prevent grease from escaping.
5. Use a grease gun to liberally lubricate the new bearings.
6. Repeat Steps 1 through 5 on the remaining vehicles.

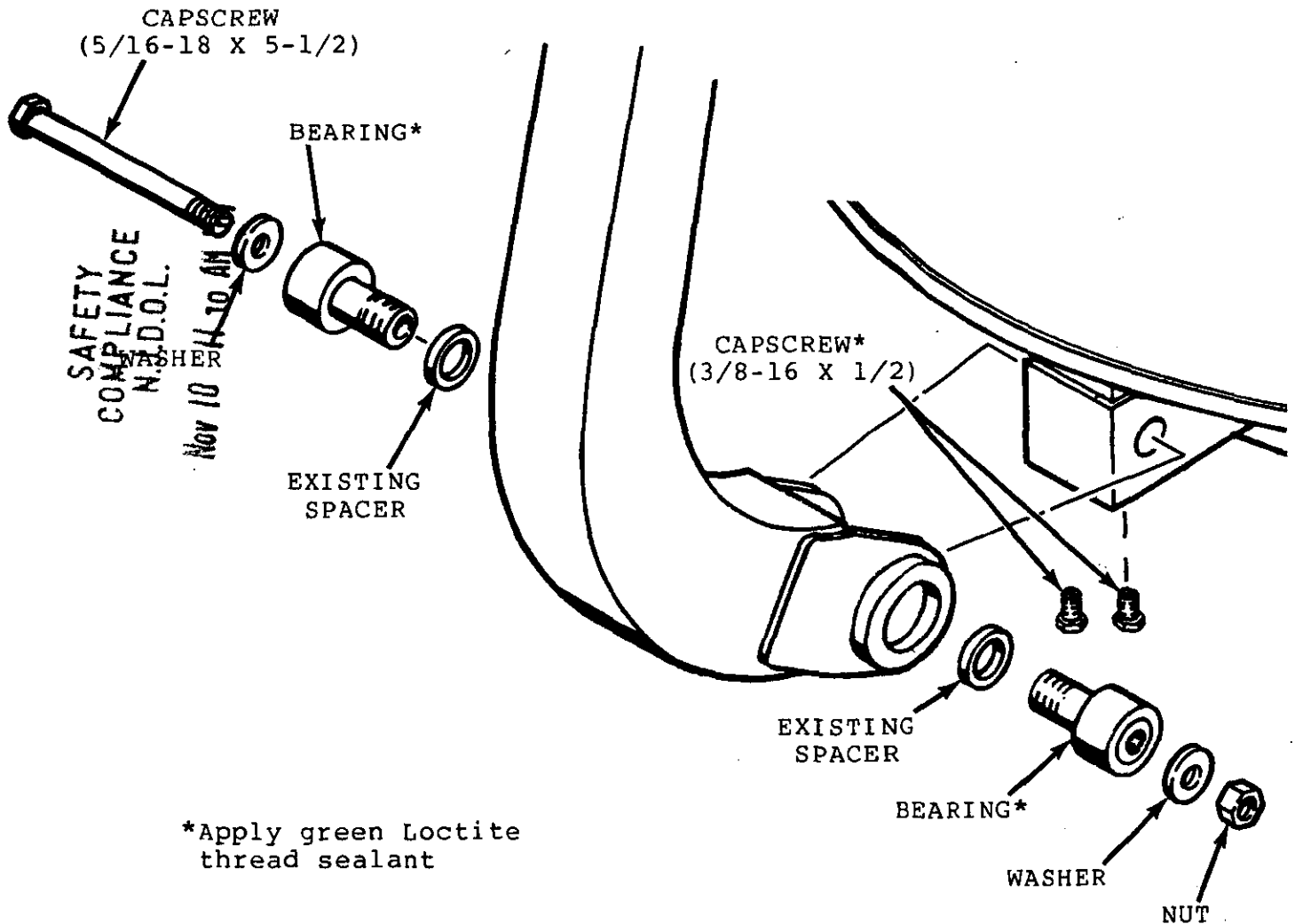





# Certification of Compliance

SERVICE BULLETIN B76-0306-00

We hereby certify the procedure outlined in the above-mentioned service bulletin has been performed on the \_\_\_\_\_

Serial No(s) \_\_\_\_\_, in accordance

with the instructions and specifications supplied by Chance Manufacturing Company, Inc.

Date Bulletin Received \_\_\_\_\_

Date Procedure Performed \_\_\_\_\_

Name and Address of Person performing Procedure:

\_\_\_\_\_  
\_\_\_\_\_

**Attested:**

Owner \_\_\_\_\_

Maintenance Supervisor \_\_\_\_\_

Address \_\_\_\_\_

Address \_\_\_\_\_

City \_\_\_\_\_ State \_\_\_\_\_

City \_\_\_\_\_ State \_\_\_\_\_

By: \_\_\_\_\_

Date: \_\_\_\_\_

Date: \_\_\_\_\_

**Results:** \_\_\_\_\_

\_\_\_\_\_  
\_\_\_\_\_  
\_\_\_\_\_

This certification must be completed and returned to CHANCE MANUFACTURING COMPANY, INC. no later than January 1, 1988.

10/14/80 11:00 AM  
CHANCE MANUFACTURING CO. INC.  
MILWAUKEE, WIS.



Number: B392R1016-0

Date: September 9, 1987

Supersedes:

---

---

## SERVICE BULLETIN

---

---

Effective Serial Numbers: 392-008-86 through 392-010-86

Ride: THUNDERBOLT

Subject: Vehicle Frame  
Pivot Modification

As a safety precaution, CHANCE RIDES, INC. requires that the owners of THUNDERBOLT amusement rides with the above noted serial numbers perform the modification described in this bulletin. This modification will provide improved bearing retention in the vehicle frame pivot.

Order kit number K76-0306-00, which includes all necessary parts and hardware for one complete ride. Install the kit using the instructions provided on the reverse side of this bulletin. Fill out the attached Certification Of Compliance for the installation no later than January 1, 1988.

### PARTS LIST

Kit Number K76-0306-00 Vehicle Frame Pivot Modification

<u>Quantity</u>	<u>Part Number</u>	<u>Description</u>
36	376-04416	BEARING (392-136-001)
18	686-07531	CAPSCREW Gr.8 (5/16-18 x5-1/2)
18	691-48044	NUT - Lock (5/16-18)
36	696-85306	WASHER (5/16)
36	686-07662	CAPSCREW (3/8-16 x 1/2)

## INSTALLATION INSTRUCTIONS

All work must be performed by a competent, qualified mechanics, capable of understanding the function of the parts and their proper installation. Read these instructions thoroughly and make sure you understand them before installing the kit.

1. Remove all four set screws from the vehicle frame pivot.
2. Unscrew and discard the bearing on one side of the vehicle. Be sure to keep the spacer. Install the new bearing and existing spacer in the frame using green Loctite thread sealant, and tighten the bearing. Repeat the procedure on the other side of the vehicle.
3. Install the 5/16-18 x 5-1/2 capscrew, washers and nut through the new bearings as shown. Tighten the nut to 15-18 lb-ft.
4. Install 3/8-16 x 1/2 capscrews in the two set screw holes using green Loctite thread sealant, to prevent grease from escaping.
5. Use a grease gun to liberally lubricate the new bearings.
6. Repeat Steps 1 through 5 on the remaining vehicles.

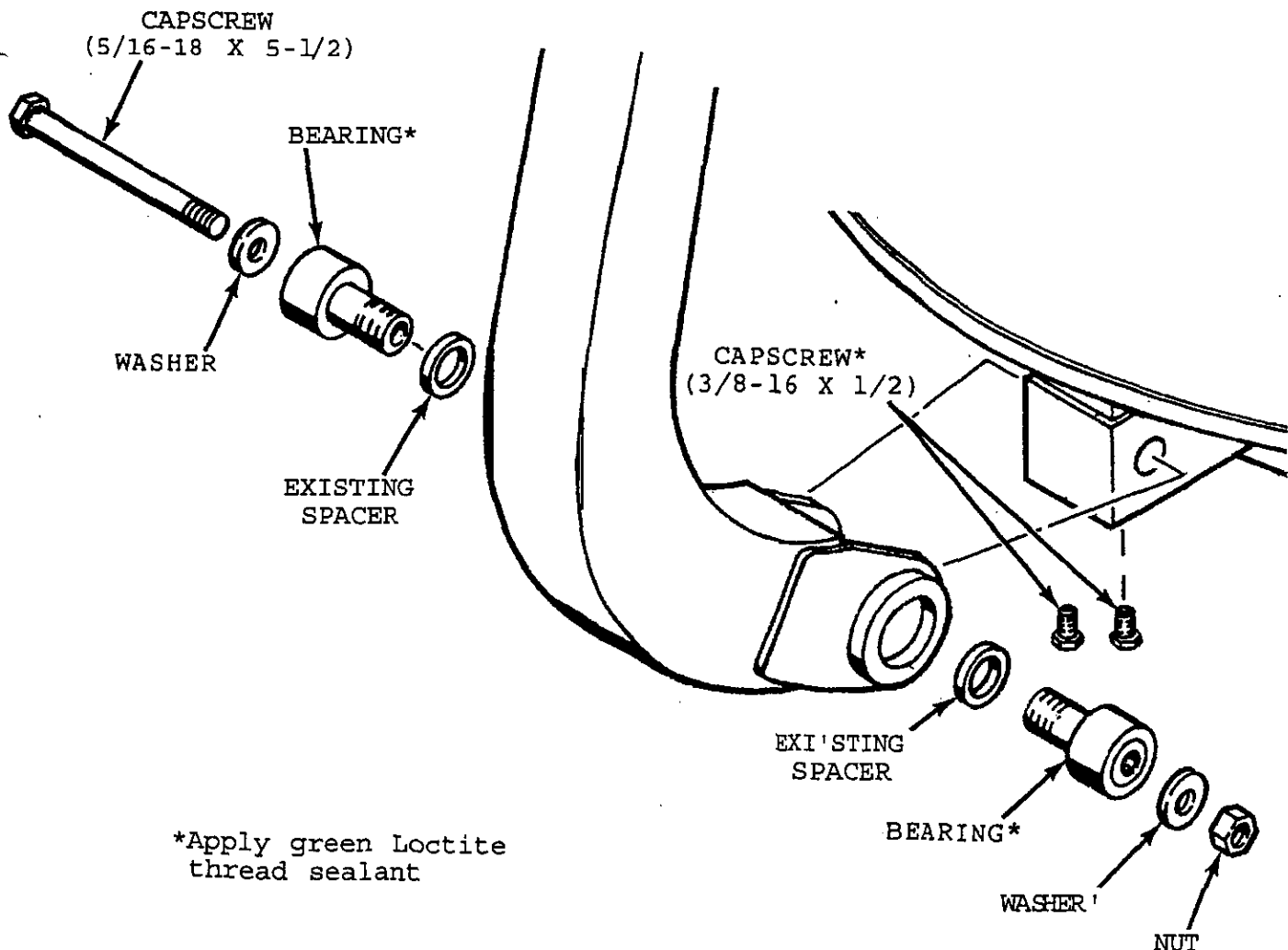



Number: B76-0317-00

Date: March 21, 1988

Supersedes:

*America's Largest Manufacturer of Amusement Rides*

# SERVICE BULLETIN

Effective Serial Numbers: 85-53001 through 85-53007

Ride: THUNDERBOLT

Subject: Master Sweep Bearing  
Cap Rework

As a safety precaution, CHANCE MANUFACTURING CO., INC. requires that the owners of THUNDERBOLT amusement rides with the above noted serial numbers perform the modification described in this bulletin. This modification will provide improved retention of the master sweep bearings in the center hub.

Order kit number K76-0317-00, which includes all necessary parts and hardware for one complete ride. Install the kit using the instructions provided on the following pages of this bulletin. Fill out the attached Certification Of Compliance for the installation within 15 days of receipt of the kit.

## PARTS LIST

Kit Number K76-0317-00 Master Sweep Bearing Cap Rework

<u>Item No.</u>	<u>Quantity</u>	<u>Part Number</u>	<u>Description</u>
1	1	376-31703	Drill Guide (K76-0317-01)
2	4	686-09831	Capscrew - 7/8-9 x 4-1/2" (Grade 8)
3	4	376-85568	Hardened Washer - Special (K76-0317-02)
4	1	---	Tap (7/8-9 Thread)
5	3	686-09512	Bolt - 3/4-10 x 1-1/2"
6	3	686-10226	Bolt - 7/8-9 x 1-1/2"
7	1	---	Drill Bit (49/64" Diameter)
8	1	---	Drill Bit (29/32" Diameter)

Factory and Sales Office: 4219 Irving • P.O. Box 12328 • Wichita, Kansas 67277 • (316) 942-7411

## INSTALLATION INSTRUCTIONS

1. Use the chain hoist to remove the two sweeps from the master sweep.
2. Using the hoist to support the weight of the master sweep, remove the four 3/4-10 bolts from the bearing caps. Remove the cap and move the master sweep out of the way.

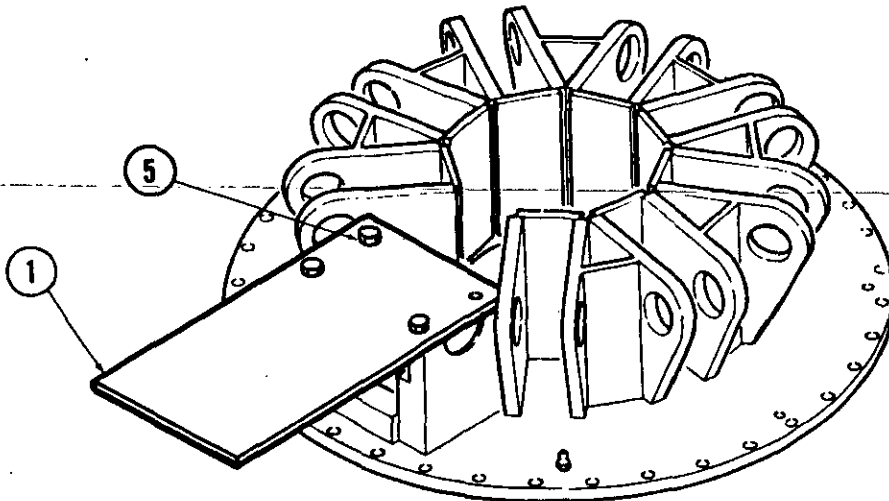

3. Use three 3/4-10 x 1-1/2" bolts (Item #5) to mount the drill guide (Item #1) to the bearing blocks on the center hub as shown.

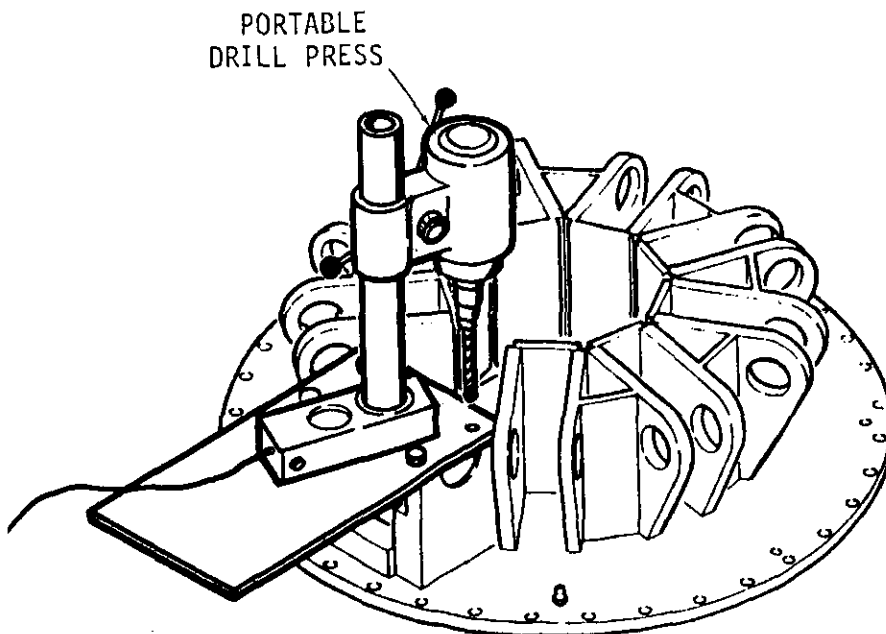

4. Using a 1-1/4" capacity portable drill press with a magnetic base, locate the drill exactly over the existing threaded hole. Drill the hole to 49/64" diameter, 3" deep, using the bit provided (Item #7). DO NOT USE A HAND-HELD DRILL MOTOR.

5. Tap the hole to 7/8-9, 2-1/2" deep using the tap provided (Item #4). Install a 7/8-9 x 1-1/2" bolt.(Item #6).
6. Remove the next 3/4-10 bolt and repeat Steps 4 and 5 on that hole.
7. Repeat Steps 4, 5 and 6 until all four holes have been drilled and tapped to 7/8-9.
8. Remove the capscrews and the drilling guide.
9. Drill the four holes in the bearing cap to 29/32" diameter, using a drill press and the drill bit provided (Item #8). DO NOT USE A HAND HELD DRILL MOTOR.

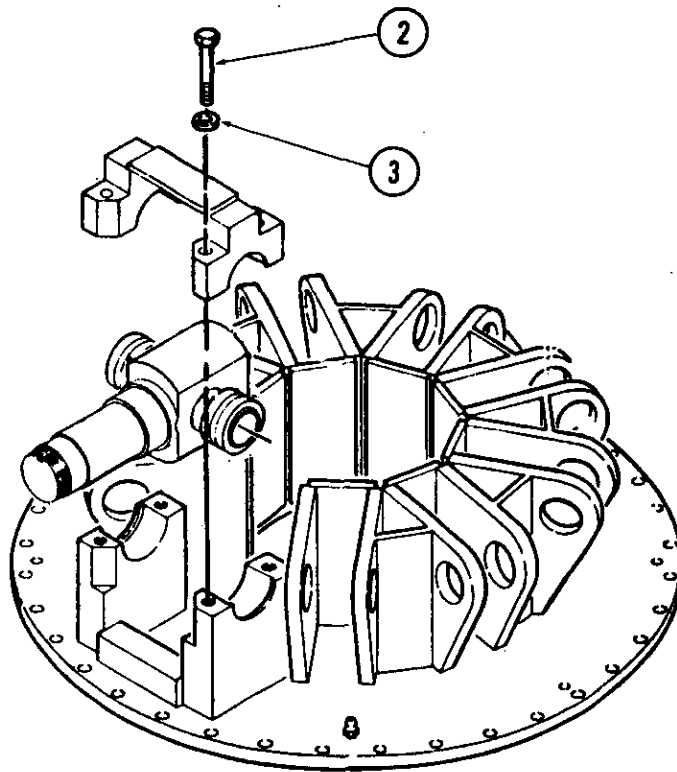

10. Install the master sweep and bearing cap using the 7/8-9 capscrews (Item #2) with the special hardened flatwashers (Item #3) under the heads. Tighten the capscrew to 460 ft-lbs. torque.
11. Reassemble the sweeps to the master sweep.
12. Check the torque of the capscrews at weekly intervals or at every set-up, whichever occurs first.



## Certification of Compliance

SERVICE BULLETIN B76-0317-00

We hereby certify the procedure outlined in the above-mentioned service bulletin has been performed on the \_\_\_\_\_

Serial No(s) \_\_\_\_\_, in accordance with the instructions and specifications supplied by Chance Manufacturing Company, Inc.

Date Bulletin Received \_\_\_\_\_

Date Procedure Performed \_\_\_\_\_

Name and Address of Person performing Procedure:

\_\_\_\_\_  
\_\_\_\_\_

**Attested:**

Owner \_\_\_\_\_

Maintenance Supervisor \_\_\_\_\_

Address \_\_\_\_\_

Address \_\_\_\_\_

City \_\_\_\_\_ State \_\_\_\_\_

City \_\_\_\_\_ State \_\_\_\_\_

By: \_\_\_\_\_

Date: \_\_\_\_\_

Date: \_\_\_\_\_

**Results:** \_\_\_\_\_  
\_\_\_\_\_  
\_\_\_\_\_  
\_\_\_\_\_

This certification must be completed and returned to Chance Manufacturing Company, Inc. within fifteen (15) days of receipt of the bulletin



Number: B392R1020-0

Date: March 21, 1988

Supersedes:

---

---

## SERVICE BULLETIN

---

---

Effective Serial Numbers: 392-008-86 through 392-014-87

Ride: THUNDERBOLT

Subject: Master Sweep Bearing  
Cap Rework (Capscrews)

As a safety precaution, CHANCE RIDES, INC. requires that the owners of THUNDERBOLT amusement rides with the above noted serial numbers perform the modification described in this bulletin. This modification will provide improved retention of the master sweep bearings in the center hub.

Order kit number K76-0317-00, which includes all necessary parts and hardware for one complete ride. Install the kit using the instructions provided on the following pages of this bulletin. Fill out the attached Certification Of Compliance for the installation within 15 days of receipt of the kit.

### PARTS LIST

Kit Number K76-0317-00 Master Sweep Bearing Cap Rework

Item No.	Quantity	Part Number	Description
1	1	376-31703	Drill Guide (K76-0317-01)
2	4	686-09831	Capscrew - 7/8-9 x 4-1/2" (Grade 8)
3	4	376-85568	Hardened Washer - Special (K76-0317-02)
4	1	---	Tap (7/8-9 Thread)
5	3	686-09512	Bolt - 3/4-10 x 1-1/2"
6	3	686-10226	Bolt - 7/8-9 x 1-1/2"
7	1	---	Drill Bit (49/64" Diameter)
8	1	---	Drill Bit (29/32" Diameter)



## INSTALLATION INSTRUCTIONS

1. Use the chain hoist to remove the two sweeps from the master sweep.
2. Using the hoist to support the weight of the master sweep, remove the four  $3/4$ -10 bolts from the bearing caps. Remove the cap and move the master sweep out of the way.

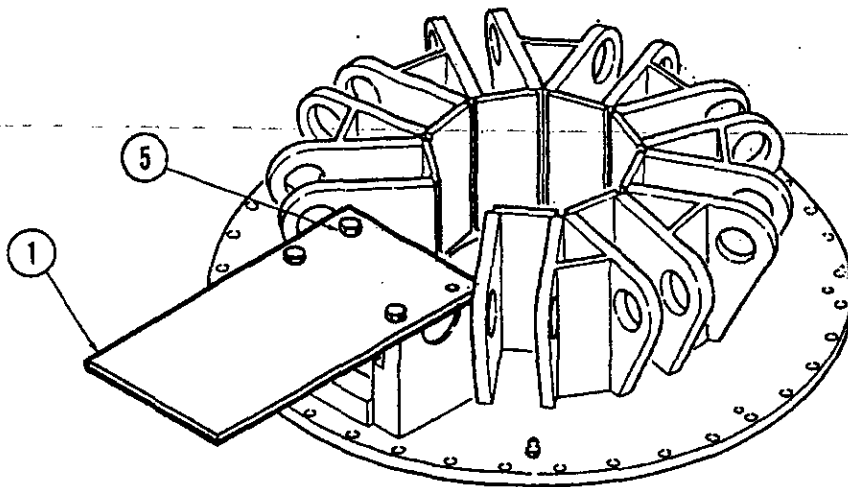

3. Use three  $3/4$ -10 x  $1-1/2$ " bolts (Item #5) to mount the drill guide (Item #1) to the bearing blocks on the center hub as shown.

PORTABLE  
DRILL PRESS,

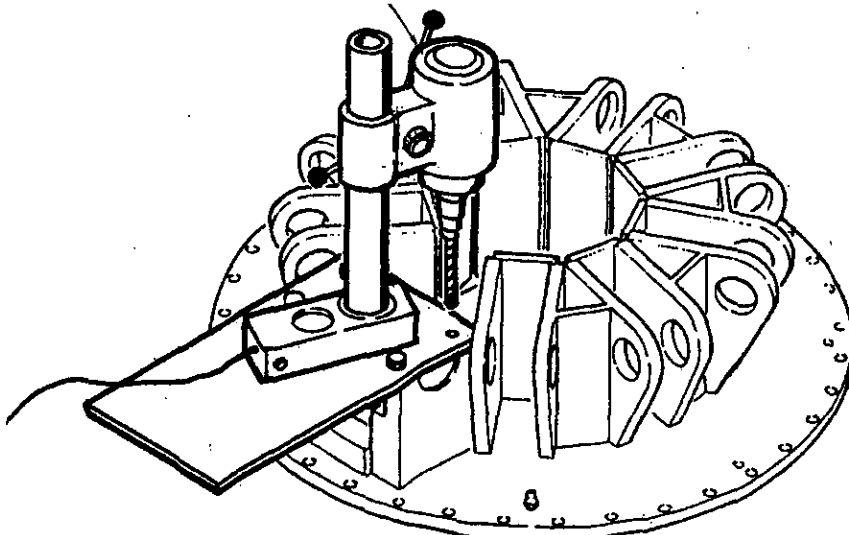

4. Using a  $1-1/4$ " capacity portable drill press with a magnetic base, locate the drill exactly over the existing threaded hole. Drill the hole to  $49/64$ " diameter, 3" deep, using the bit provided (Item# 7). DO NOT USE A HAND-HELD DRILL MOTOR.

5. Tap the hole to 7/8-9, 2-1/2" deep using the tap provided (Item #4). Install a 7/8-9 x 1-1/2" bolt.(Item #6).
6. Remove the next 3/4-10 bolt and repeat Steps 4 and 5 on that hole.
7. Repeat Steps 4, 5 and 6 until all four holes have been drilled and tapped to 7/8-9.
8. Remove the capscrews and the drilling guide.
9. Drill the four holes in the bearing cap to 29/32" diameter, using a drill press and the drill bit provided (Item #8). DO NOT USE A HAND HELD DRILL MOTOR.

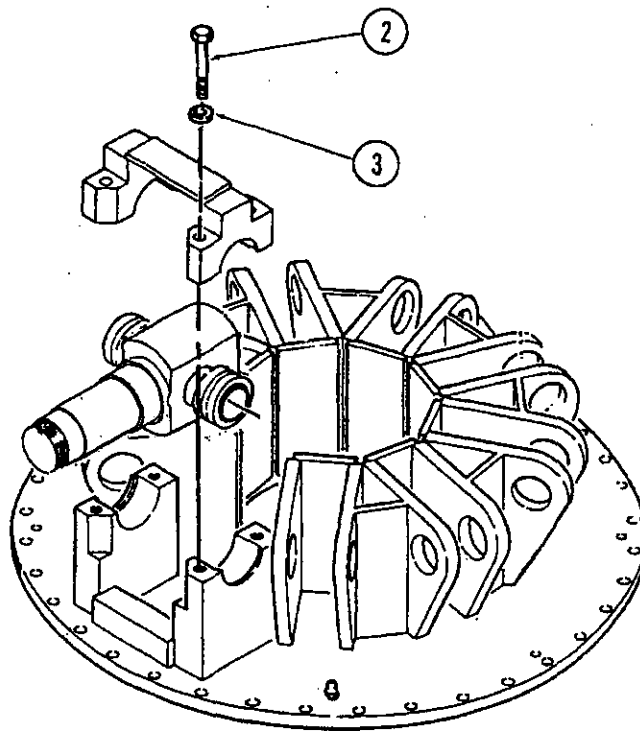

10. Install the master sweep and bearing cap using the 7/8-9 capscrews (Item #2) with the special hardened flatwashers (Item #3) under the heads. Tighten the capscrew to 460 ft-lbs. torque.
11. Reassemble the sweeps to the master sweep.
12. Check the torque of the capscrews at weekly intervals or at every set-up, whichever occurs first.



Number: B392R1023-0

Date: Nov. 28, 1988

---

---

## SERVICE BULLETIN

---

---

Effective Serial Number: All Units

Ride: THUNDERBOLT

Subject: Operation Of Shut-Off  
Valves For Hydraulic  
Leveling Jacks

As a safety precaution, CHANCE RIDES, INC. requires that all owners of THUNDERBOLT amusement rides instruct their employees to follow the correct procedure for operation of the shut-off valves for the hydraulic leveling jacks. Safety decals are enclosed with this bulletin to remind employees of these instructions.

Install the five decals (part no 277-22B200), one on each leveling jack and one near the shut-off valves. After the decals have been installed, always follow the recommended operating procedures.

### **WARNING**

**RETRACT THE HYDRAULIC LEVELING JACKS AND CLOSE SHUT-OFF VALVES FOR THE JACKS DURING NORMAL RIDE OPERATION.**

If the valves are left open, hydraulic pressure from the drive system, or pressure from hydraulic oil expanding due to heat can cause one or more of the jacks to extend, making the ride unstable. Injuries to passengers and/or bystanders can result.



**INSPECTION PROCEDURE**

Inspect the spreader bar system on your ride, comparing it to the illustrations on the following pages.

**EQUAL LENGTH SPREADER BARS**

If your ride has equal length spreader bars and a spring-loaded spreader bar as shown in the illustration on the opposite page, you must replace the spring-loaded spreader bar. Order the following kit:

**SPRING-LOADED SPREADER BAR REWORK KIT No. K37-0330-01**  
(consists of these parts necessary for one complete ride)

**PARTS LIST**

<u>Item</u>	<u>Part No.</u>	<u>Description</u>	<u>Qty.</u>
1	376-0399700	SPRING SPREADER BAR ASSEMBLY (392-201A005) . . .	1
	376-7189900	..Spring Loaded Spreader Bar (392-210-001) . . .	1
	237-0444200	..Rod End . . . . .	2
	691-4764600	..Jam Nut (1-1/4-12) . . . . .	2
2	390-5230000	TAPER PIN - 3/4 x 5-11/16" (CSN10A05-07) . . . . .	2
3	694-5190200	HAIRPIN - 5/32" . . . . .	2
4	B37-0251-0B	BULLETIN - Spreader Bar Instructions . . . . .	1

**IMPORTANT:** The new rod ends provided with the kit are of a new design and do not require bushings. **DO NOT USE THE OLD ROD ENDS WITH THE NEW SPRING-LOADED SPREADER BAR.** Discard the old rod ends.

68. WA 40 11 0 771  
SAFETY  
COMPLIANCE  
M.J.D.O.L.

**INSPECTION PROCEDURE (continued)**

**EQUAL LENGTH SPREADER BARS**

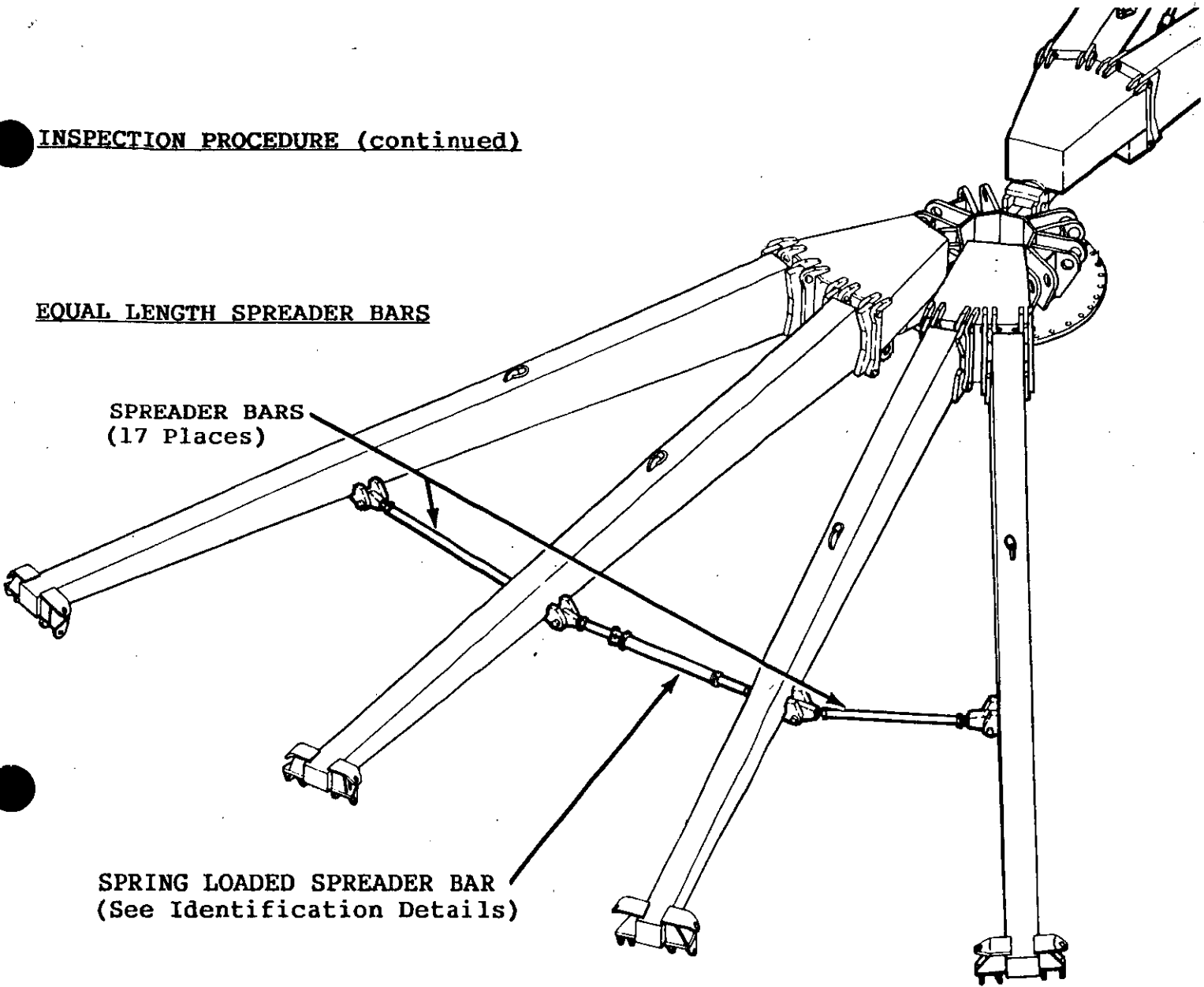

**NEW STYLE  
SPRING-LOADED SPREADER BAR**

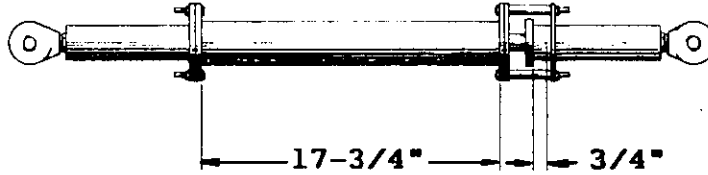

**OLD STYLE  
SPRING LOADED SPREADER BAR**

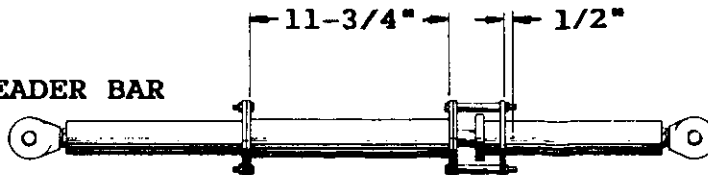

INSPECTION PROCEDURE (continued)

UNEQUAL LENGTH SPREADER BARS

If your ride has unequal length spreader bars as shown in the above illustration, you must replace the entire spreader bar system. Order the following kit:

SPREADER BAR SYSTEM REWORK KIT No. K37-0330-02  
(consists of these parts necessary for one complete ride)

PARTS LIST

<u>Item</u>	<u>Part No.</u>	<u>Description</u>	<u>Qty.</u>
1	376-0399600	SOLID SPREADER BAR ASSEMBLY (392-201A004)	17
	337-4162300	..Spreader Bar (337-598-001)	1
	237-0444200	..Rod End	2
	691-4764600	..Jam Nut (1-1/4-12)	2
2	376-0399700	SPRING SPREADER BAR ASSEMBLY (392-201A005)	1
	376-7189900	..Spring Loaded Spreader Bar (392-210-001)	1
	237-0444200	..Rod End	2
	691-4764600	..Jam Nut (1-1/4-12)	2
3	390-5230000	TAPER PIN - 3/4 x 5-11/16" (CSN10A05-07)	2
4	694-5190200	HAIRPIN - 5/32"	2
5	B37-0251-0B	BULLETIN - Spreader Bar Instructions	1

**IMPORTANT:** The new rod ends provided with the kit are of a new design and do not require bushings. DO NOT USE THE OLD ROD ENDS WITH THE NEW SPREADER BAR. Discard the old rod ends.

68. MAR 11 0 51  
SAFETY  
COMPLIANCE  
H.D.O.L.

INSPECTION PROCEDURE (continued)

UNEQUAL LENGTH SPREADER BARS

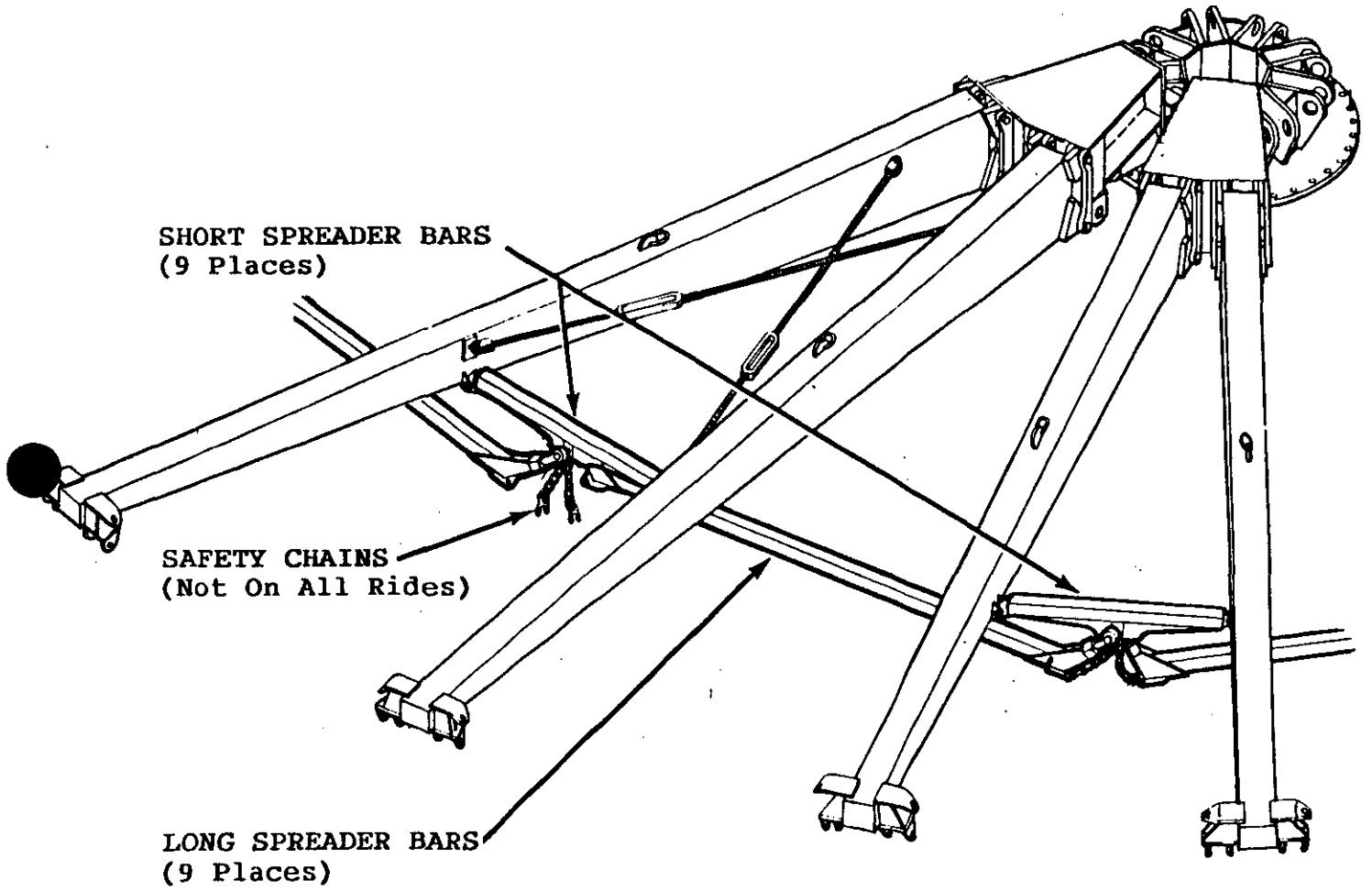



INSPECTION PROCEDURE (continued)

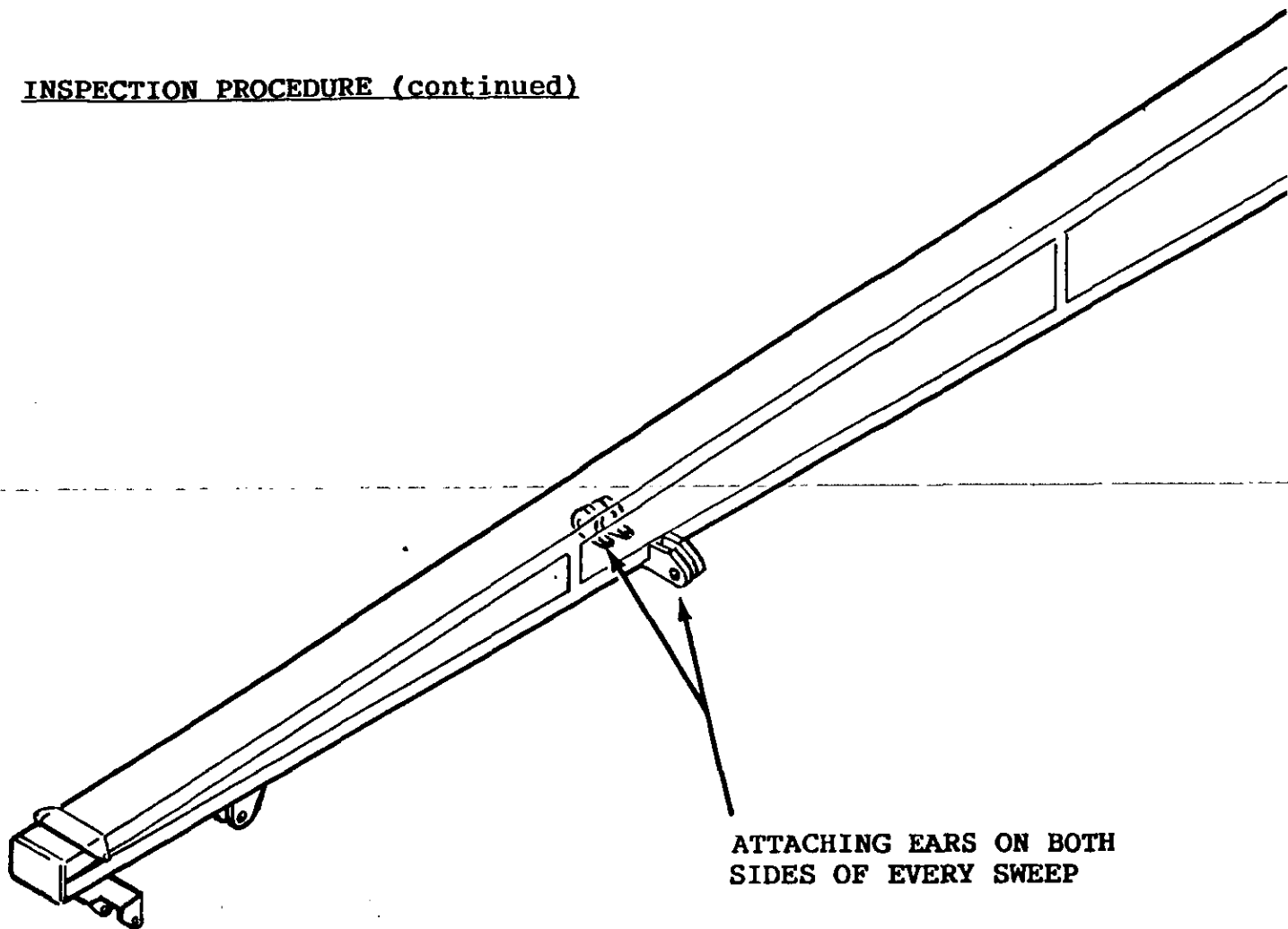

ATTACHING EARS ON BOTH SIDES OF EVERY SWEEP

If your ride does not have a spreader bar attaching ear on both sides of every sweep, you must install the remaining ears before replacing the spreader bar system. Order the following kit:

SPREADER BAR ATTACHING EAR KIT No. K37-0333-00  
 (consists of these parts necessary for one complete ride)

PARTS LIST

<u>Item</u>	<u>Part No.</u>	<u>Description</u>	<u>Qty.</u>
1	376-4237400	EAR AND BUSHING WELDMENT-R.H.(392-565-001) . . . . .	9
2	376-4237500	EAR AND BUSHING WELDMENT-L.H.(392-565-002) . . . . .	9
3	376-2737500	TOOL - Alignment (392-566-001) . . . . .	1
4	---	INSTALLATION INSTRUCTIONS . . . . .	1

68. 11 10 11  
 SAFETY COMPLIANCE  
 J.D.O.L.



**Certification of Compliance**  
**SERVICE BULLETIN** B76-0332-00

We hereby certify the procedure outlined in the above-mentioned service bulletin has been performed on the \_\_\_\_\_  
Serial No(s) \_\_\_\_\_, in accordance with the instructions and specifications supplied by Chance Manufacturing Company, Inc.

Date Bulletin Received \_\_\_\_\_

Date Procedure Performed \_\_\_\_\_

Name and Address of Person performing Procedure:

\_\_\_\_\_  
\_\_\_\_\_

**Attested:**

Owner \_\_\_\_\_

Maintenance Supervisor \_\_\_\_\_

Address \_\_\_\_\_

Address \_\_\_\_\_

City \_\_\_\_\_ State \_\_\_\_\_

City \_\_\_\_\_ State \_\_\_\_\_

By: \_\_\_\_\_

Date: \_\_\_\_\_

Date: \_\_\_\_\_

**Results:** \_\_\_\_\_  
\_\_\_\_\_  
\_\_\_\_\_  
\_\_\_\_\_

This certification must be completed and returned to Chance Manufacturing Company, Inc. within fifteen (15) days of receipt of the bulletin



B392R1004-A

Dec. 31, 1988

A392R1004-0  
(6-30-86)

America's Largest Manufacturer of Amusement Rides

---

---

# SERVICE BULLETIN

---

---

All Units Which Have Been Reworked To Comply  
With Service Bulletin B392R1027-0.

THUNDERBOLT

Installation, Inspection And  
Adjustment Of Spreader Bars

Safety Alert Bulletin Number A392R1004-0 is superseded by this Service Bulletin. It is no longer in effect and should be destroyed.

CHANCE RIDES, INC. wishes to emphasize the importance of the spreader bars on THUNDERBOLT amusement rides. Worn, damaged or improperly adjusted spreader bars can cause damage to the sweeps, spreader bars and center hub, and cause rough operation, which can result in injury to passengers.

READ THESE INSTRUCTIONS THOROUGHLY AND BECOME FAMILIAR WITH THE ENTIRE PROCEDURE. All work must be performed by competent, qualified mechanics, capable of understanding the function of the parts and their proper installation.

Complete the spreader bar inspection, installation and adjustment procedure using the instructions on the following pages of this bulletin. If you have any questions regarding the instructions or this procedure, contact the CHANCE CUSTOMER SERVICE DEPARTMENT.



Number: B392R1027-0

Date: Dec. 31, 1988

Supersedes:

---

---

## SERVICE BULLETIN

---

---

Effective Serial Numbers: 85-53008, 392-009-86 and 392-010-86

Ride: THUNDER BOLT

Subject: Spreader Bar Inspection  
And Rework

**A**

**WARNING: FAILURE TO COMPLY WITH THIS SERVICE BULLETIN CAN RESULT IN FAILURE OF THE SPREADER BAR SYSTEM AND INJURY TO PASSENGERS.**

CHANCE RIDES, INC. has developed a new spreader bar system which provides longer life of the spreader bars, sweeps and center hub, and increased passenger safety.

ALL OWNERS OF THE ABOVE NOTED THUNDERBOLT AMUSEMENT RIDES ARE REQUIRED TO PERFORM THE INSPECTION AND APPROPRIATE REWORK TO UPDATE THEIR SPREADER BARS TO THE NEW DESIGN.

Perform the inspection as described on the following pages of this bulletin to determine the necessary rework required for your ride. Order the appropriate rework kit(s) listed on the following pages of this bulletin, depending upon the configuration of your ride:

Install the kit(s) using the instructions provided with each kit. All work must be performed by competent, qualified mechanics, capable of understanding the function of the parts and their proper installation.

Fill out the attached Certification Of Compliance for the inspection and the rework within fifteen (15) days of receipt of this bulletin. If there are any questions regarding the instructions or this repair, contact the CHANCE CUSTOMER SERVICE DEPARTMENT.

**INSPECTION PROCEDURE**

Inspect the spreader bar system on your ride, comparing it to the illustrations on the following pages.

**EQUAL LENGTH SPREADER BARS**

If your ride has ~~equal length spreader bars and a spring-loaded spreader bar~~ as shown in the illustration on the opposite page, you must replace the spring-loaded spreader bar. Order the following kit:

**SPRING-LOADED SPREADER BAR REWORK KIT No. K37-0330-03**  
(consists of these parts necessary for one complete ride)

**PARTS LIST**

<u>Item</u>	<u>Part No.</u>	<u>Description</u>	<u>Qty.</u>
1	376-0399700	SPRING SPREADER BAR ASSEMBLY (392-201A005) . . .	1
	376-7189900	..Spring Loaded Spreader Bar (392-210-001) . . .	1
	237-0444200	..Rod End . . . . .	2
	691-4764600	..Jam Nut (1-1/4-12) . . . . .	2
2	390-5230000	TAPER PIN - 3/4 x 5-11/16" (CSN10A05-07) . . . . .	2
3	694-5190200	HAIRPIN - 5/32" . . . . .	2
4	B392R1004-A	BULLETIN - Spreader Bar Instructions . . . . .	1

**IMPORTANT:** The new rod ends provided with the kit are of a new design and do not require bushings. DO NOT USE THE OLD ROD ENDS WITH THE NEW SPRING-LOADED SPREADER BAR. Discard the old rod ends.

INSPECTION PROCEDURE (continued)

EQUAL LENGTH SPREADER BARS

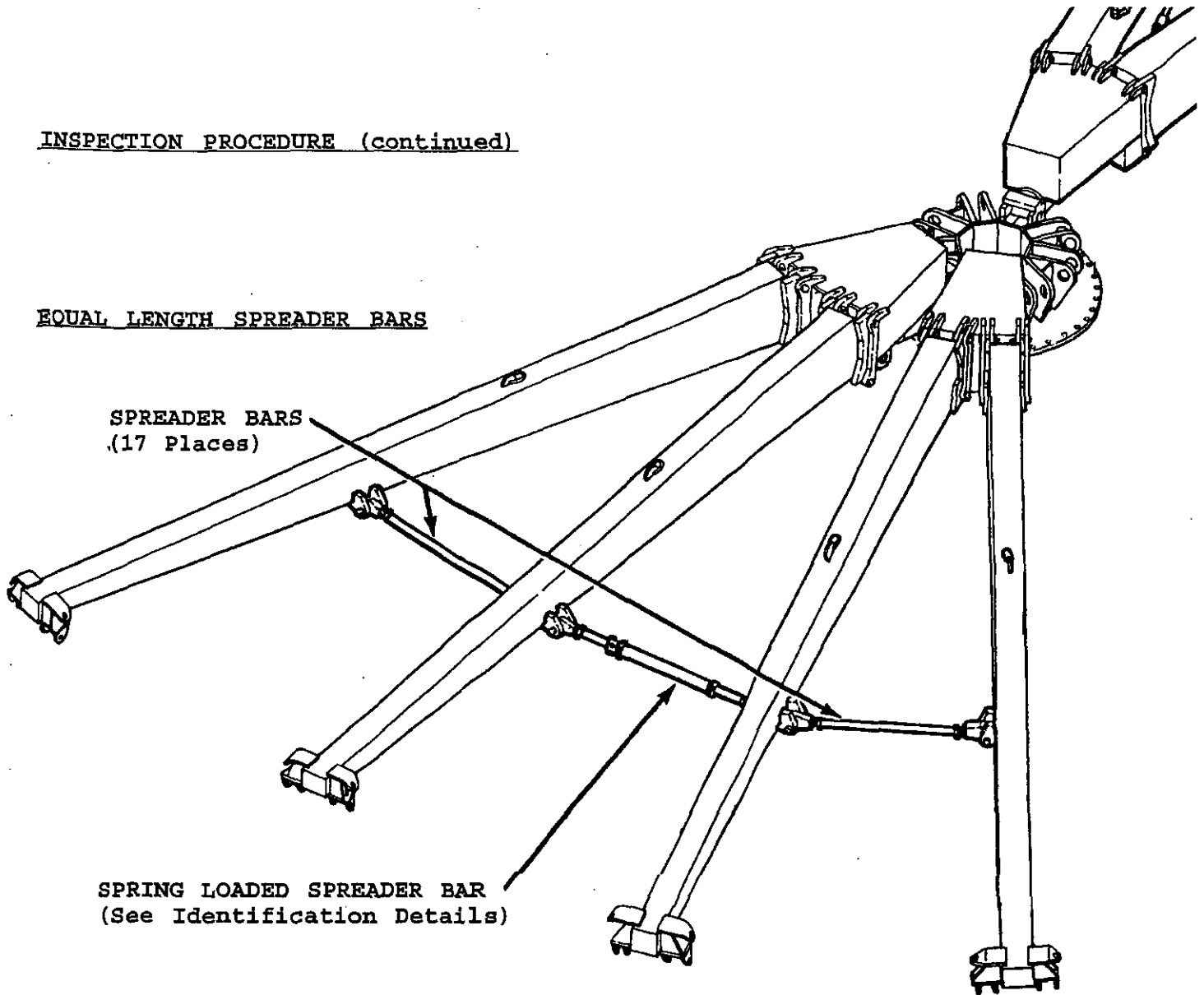

NEW STYLE  
SPRING-LOADED SPREADER BAR

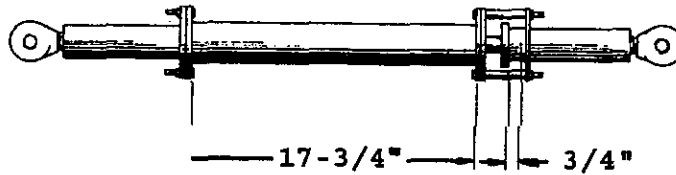

OLD STYLE  
SPRING-LOADED SPREADER BAR

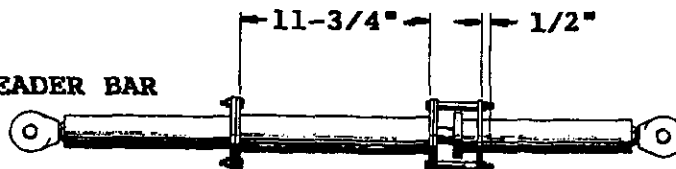

INSPECTION PROCEDURE (continued)

UNEQUAL LENGTH SPREADER BARS

If your ride has unequal length spreader bars as shown in the above illustration, you must replace the entire spreader bar system. Order the following kit:

SPREADER BAR SYSTEM REWORK KIT No. K37-0330-04  
(consists of these parts necessary for one complete ride)

PARTS LIST

<u>Item</u>	<u>Part No.</u>	<u>Description</u>	<u>Qty.</u>
1	376-0399600	SOLID SPREADER BAR ASSEMBLY (392-21A004)	17
	337-4162300	..Spreader Bar (337-598-001)	1
	237-0444200	..Rod End	2
	691-4764600	..Jam Nut (1-1/4-12)	2
2	376-0399700	SPRING SPREADER BAR ASSEMBLY (392-201A005)	1
	376-7189900	..Spring Loaded Spreader Bar (392-210-001)	1
	237-0444200	..Rod End	2
	691-4764600	..Jam Nut 1-1/4-12	2
3	390-5230000	TAPER PI - 3/4 x 5-11/16" (CSN10A05-07)	2
4	694-5190200	HAIRPIN - 5/32"	2
5	B392R1004-A	BULLETIN - Spreader Bar Instructions	1

**IMPORTANT:** The new rod ends provided with the kit are of a new design and do not require bushings. DO NOT USE THE OLD ROD ENDS WITH THE NEW SPREADER BAR. Discard the old rod ends.

INSPECTION PROCEDURE (continued)

UNEQUAL LENGTH SPREADER BARS

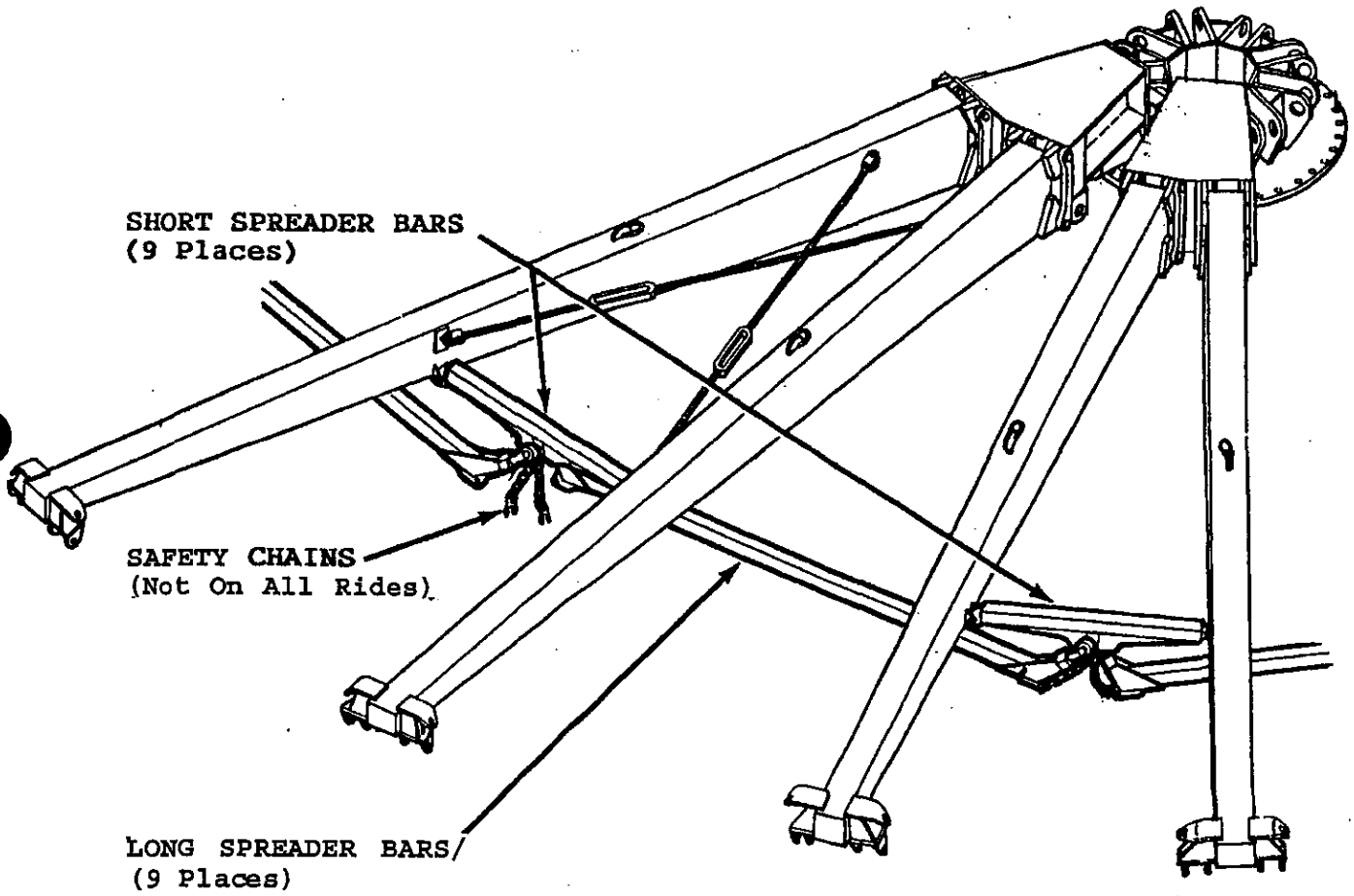



INSPECTION PROCEDURE (continued)

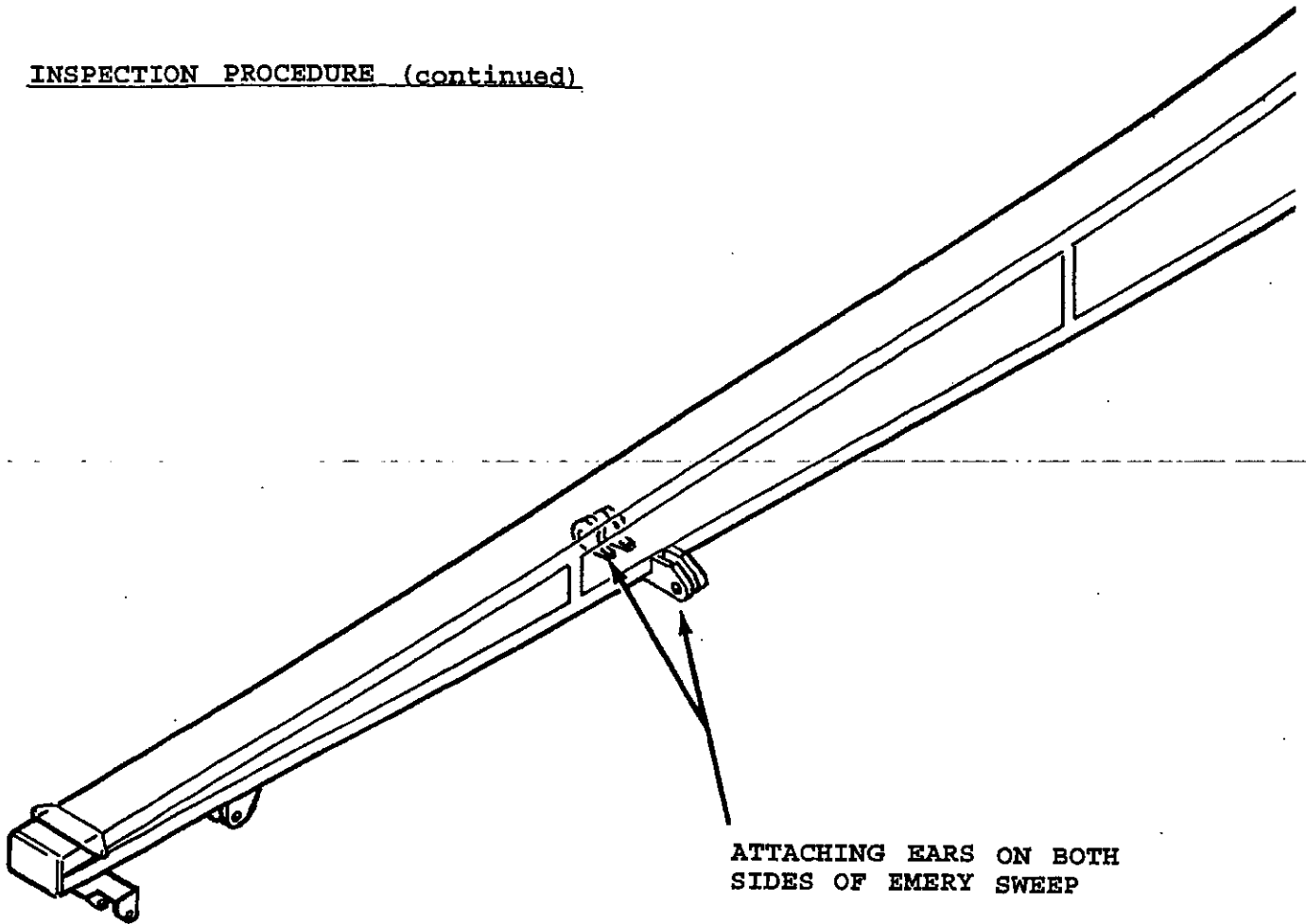

If your ride does not have a spreader bar attaching ear on both sides of every sweep, you must install the remaining ears before replacing the spreader bar system. Order the following kit:

SPREADER BAR ATTACHING EAR KIT No. K37-0333-00  
(consists of these parts necessary for one complete ride)

PARTS LIST

<u>Item</u>	<u>Part No.</u>	<u>Description</u>	<u>Qty.</u>
1	376-4237400	EAR AND BUSHING WELDMENT-R.H. (392-565-001)	. . . 9
2	376-4237500	EAR AND BUSHING WELDMENT-L.H. (392-565-002)	. . . 9
3	376-2737500	TOOL - Alignment (392-566-001)	..... 1
4	---	INSTALLATION INSTRUCTIONS	..... 1



Number: B392R1042-0

Date: July 12, 1989

Supersedes:

America's Largest Manufacturer of Amusement Rides

---

---

# SERVICE BULLETIN

---

---

Effective Serial Numbers: 86-53008 and 392-009-86 through 392-019-89

Ride: THUNDERBOLT

Subject: Hydraulic Motor Mount Rework



**WARNING: FAILURE TO COMPLY WITH THIS SERVICE BULLETIN CAN RESULT IN FAILURE OF THE DRIVE MOTOR, CAUSING THE RIDE TO STOP ABRUPTLY. THIS CAN RESULT IN INJURY TO PASSENGERS.**

It has been determined by CHANCE RIDES, INC. that the hydraulic drive motor shaft can fail during operation. The motor mount and pinion gear have been redesigned to reduce the load on the motor shaft.

All owners of the above noted THUNDERBOLT amusement rides are required to perform the rework described in this bulletin.

Perform the rework using the instructions on the following pages of this bulletin. Order Kit No. K392R1042-0 and install the kit using the instructions provided. All work must be performed by qualified personnel, capable of understanding the function of the parts and their proper installation.

Return the attached Certification Of Compliance within 15 days from receipt of the bulletin. If there are any questions regarding the instructions or this rework, contact the CHANCE CUSTOMER SERVICE DEPARTMENT.

PARTS LIST - Kit No. K392R1042-0,

The following parts are included to rework one ride.

Ref. No.	Part Number	Description	Qty. Reqd.
1.	34510300	*MOUNT ASSEMBLY (392-618-001)	1
2.	34517006	MOTOR MOUNT (392-615-001)	1
3.	34517007	MOUNT PLATE (392-616-001)	1
4.	34946300	PAD (392-621-003)	4
5.		LIFTING ADAPTER	1
6.	64806900	NUT - Pinion (1-1/2 - 12 Flexlock)	1
7.	33476502	HOSE - Hydraulic (392-650-001)	1
8.	33476503	HOSE - Hydraulic (392-650-002)	2
9.	60910600	CAPSCREW - Grade 5 (5/8-11 x 1-3/4)	8
10.	68552900	WASHER - Hardened (5/8)	8

\* For replacement parts for the motor mount assembly, refer to drawing on page 12 of this bulletin.



**WARNING:** The hydraulic motor and its mounting components are extremely heavy. To prevent personal injury, never attempt to remove or install any parts without a jack and blocking to adequately support the parts as they are lowered or raised.

## REWORK INSTRUCTIONS

**NOTE:** This rework requires partial disassembly of the ride. Use the normal tear-down or set up procedures given in the CHANCE OPERATION & MAINTENANCE MANUAL when a partially disassembled ride configuration is required.

1. Remove all cars and spreader bars from the ride. Use the chain hoist to remove all sweeps from the double sweeps.
2. Use the chain hoist to support the master double sweep and remove the bearing caps. Move the double sweep out of the way.

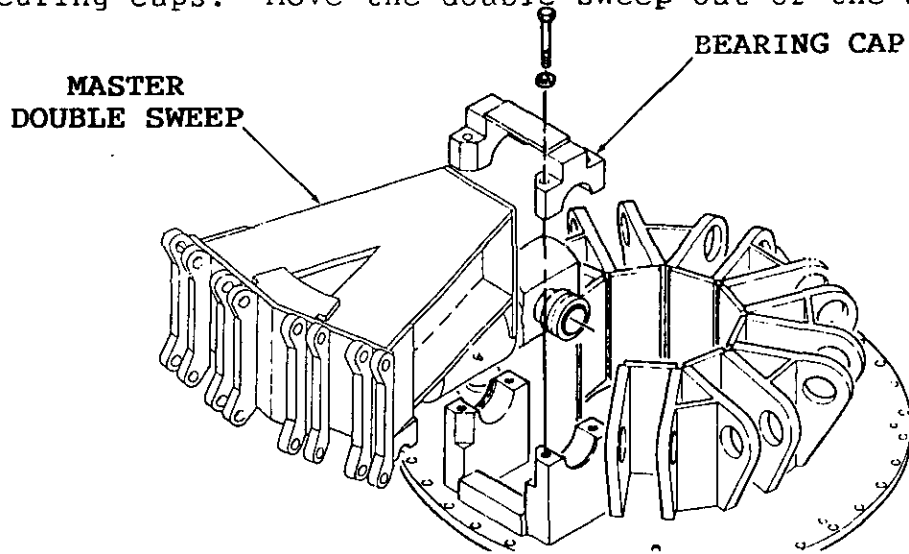

3. Use the chain hoist to remove the remaining double sweeps. Remove the sweep spindle retainer shafts and move the double sweeps out of the way.

**IMPORTANT:** Keep each retainer shaft with the sweep spindle from which it is removed. The double sweeps should be marked so that they are installed in their original positions.

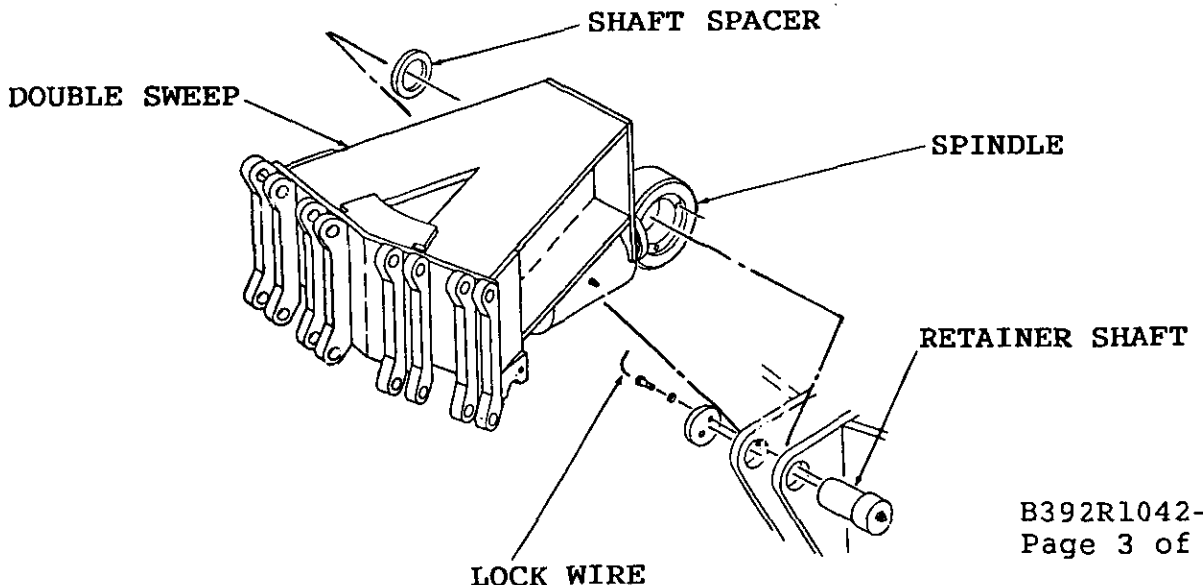

4. Remove the capscrews from the center hub.
5. With the center truss pole retracted, install chains across the trusses and attach to the center hub in four places as shown. Carefully raise the center pole, lifting the center hub. Install the safety bar.

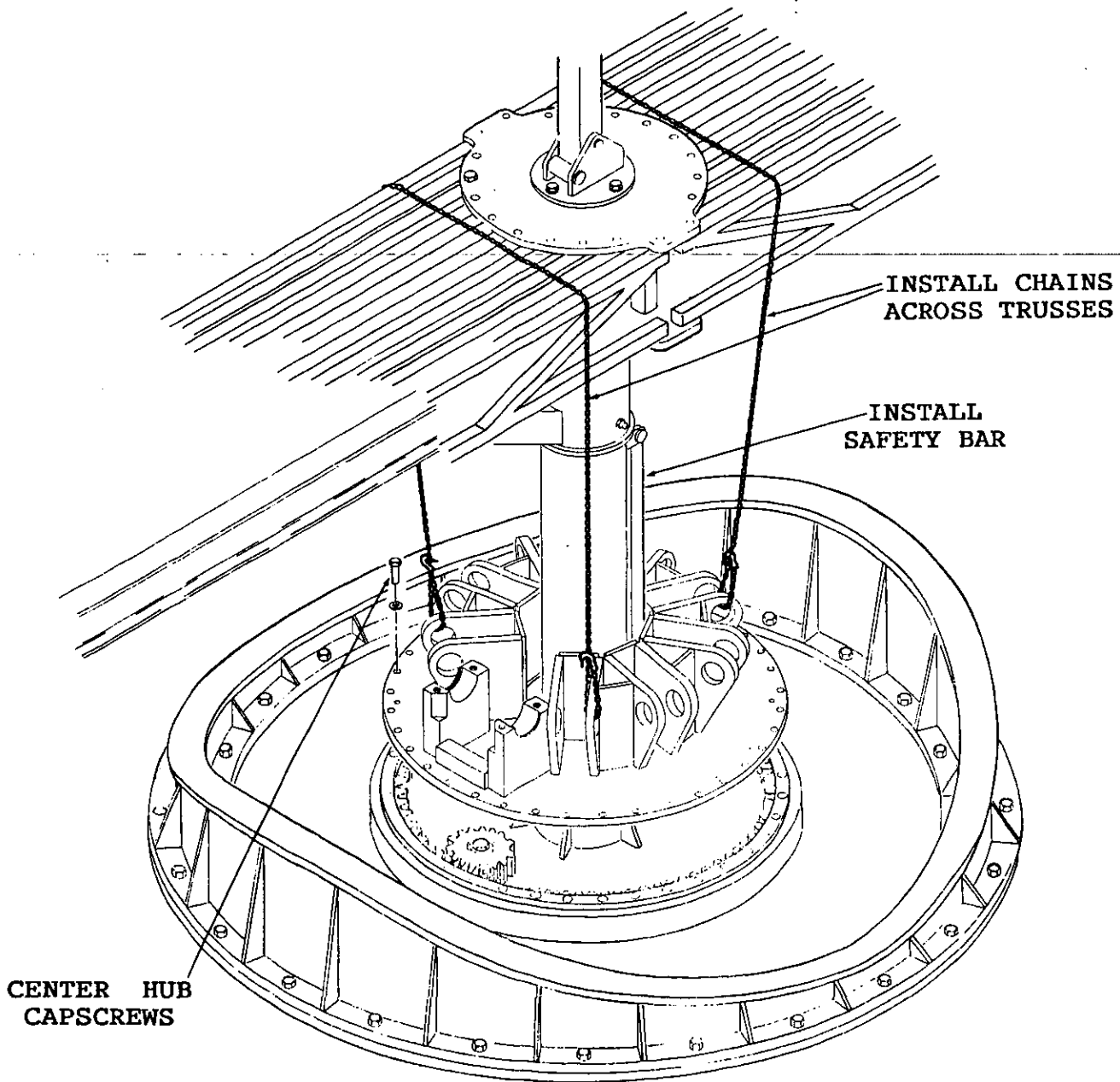

6. Remove the plumbing from the hydraulic motor. Make note of which ports are connected by each hydraulic line. These lines will be replaced with new hoses.

7. Using a hydraulic jack and blocking under the hydraulic motor, remove the five capscrews which mount the motor. Lower and remove the motor.
8. Remove the pinion nut and special washer from the motor shaft. Use a suitable puller to remove the pinion gear from the motor shaft. Return the pinion gear to the factory. Discard the nut, but save the special washer and the key.
9. Use an air/arc to remove the weld between the existing motor mount and the hub. Remove the attaching hardware and remove the motor mount. Grind the surface to remove any remaining weld.

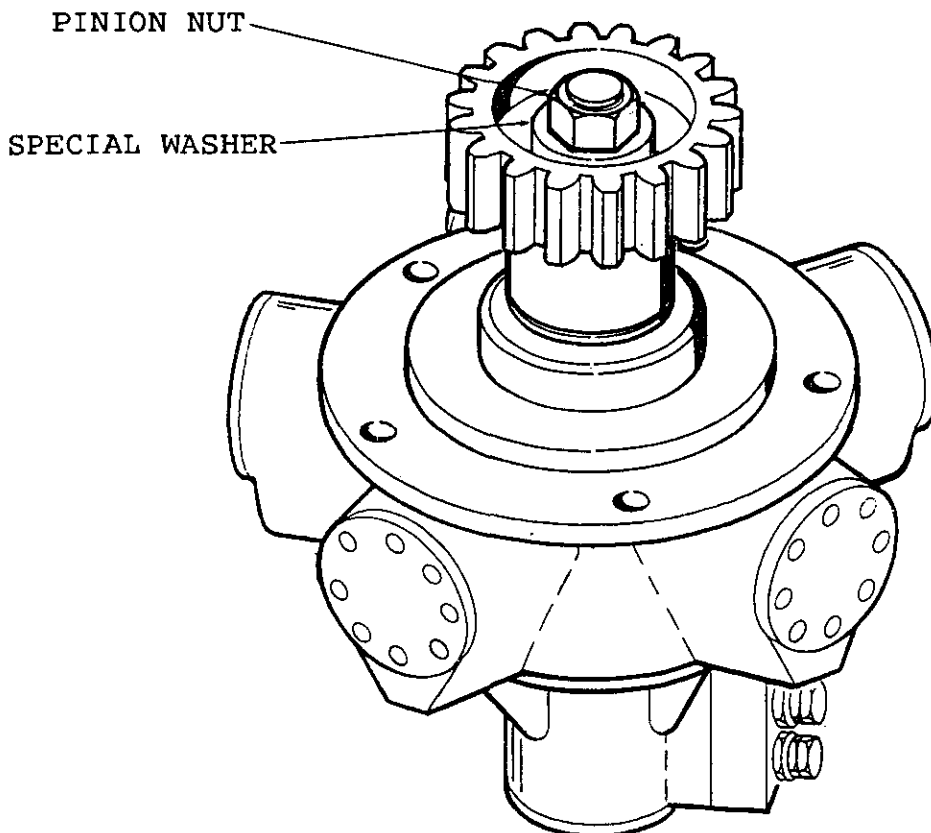
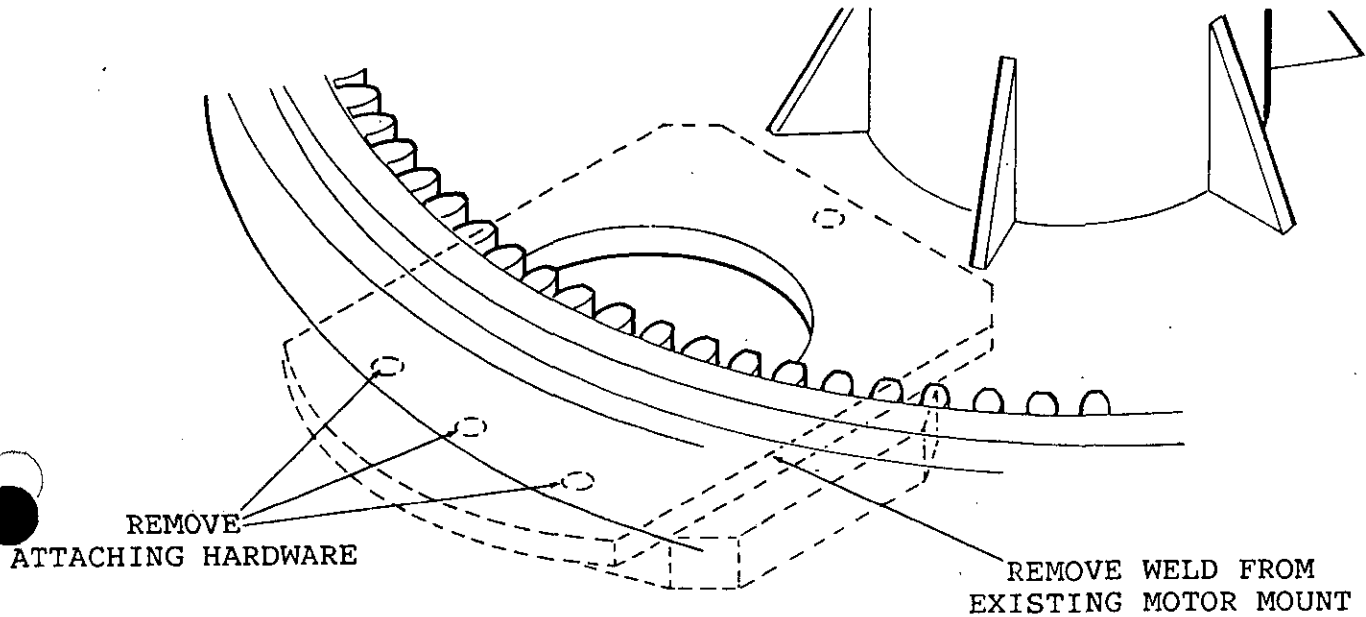

10. Install the new mount plate (Item #3) with the existing hardware, but do not tighten at this time.

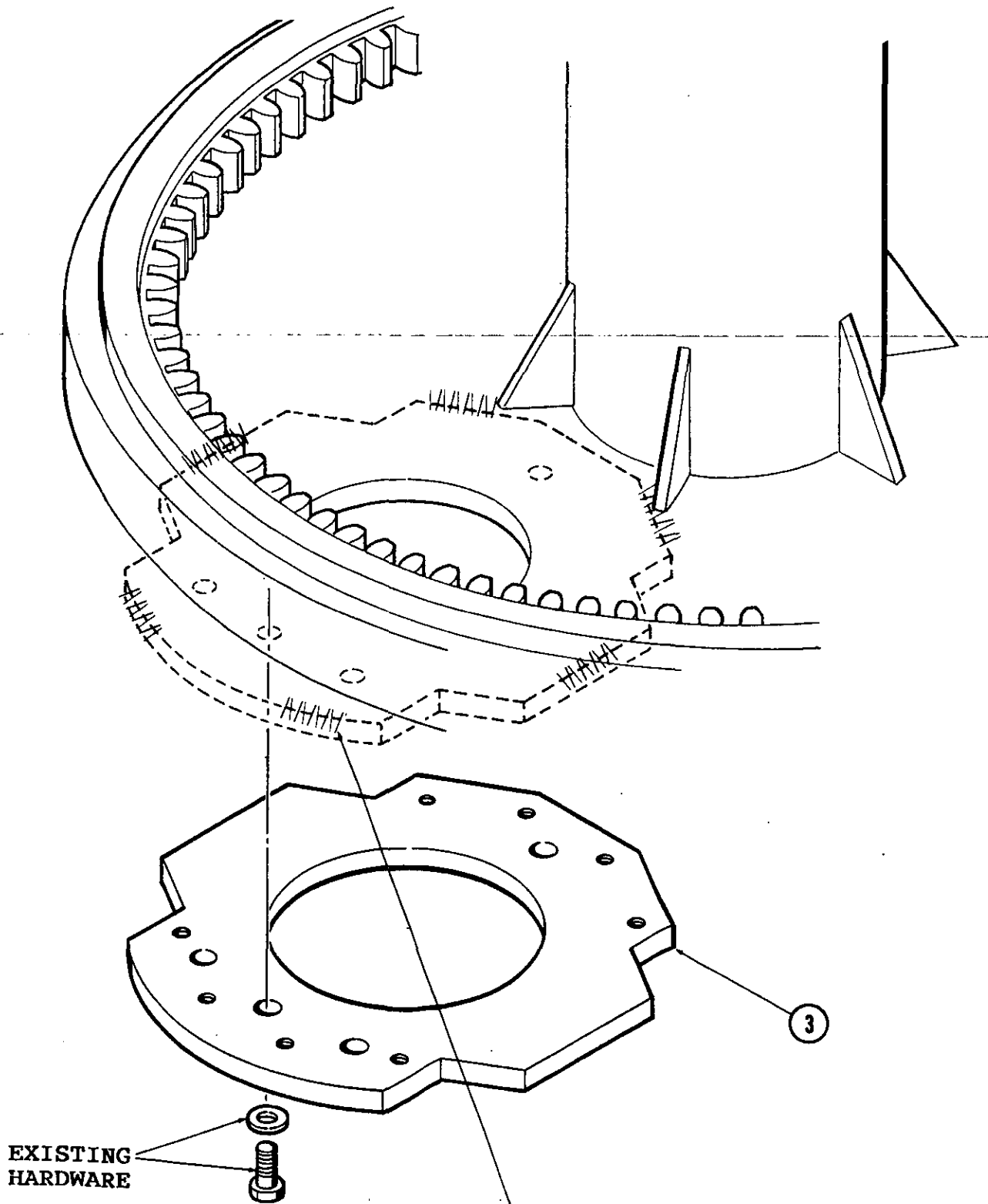

1/4" E70XX WELD, APPROXIMATELY 2" LONG  
(6 PLACES)  
**IMPORTANT: DO NOT WELD UNTIL STEP #13.**

11. Install the mount assembly (Item #1 to the mount plate using the capscrews and hardened washers (Items #9 and #10). Tighten the capscrews to 105 ft-lbs. (5/8-11 Grade 5 capscrews).

**IMPORTANT:** Loosen the jam nuts and turn all four stop bolts out until their spherical ends do not protrude.

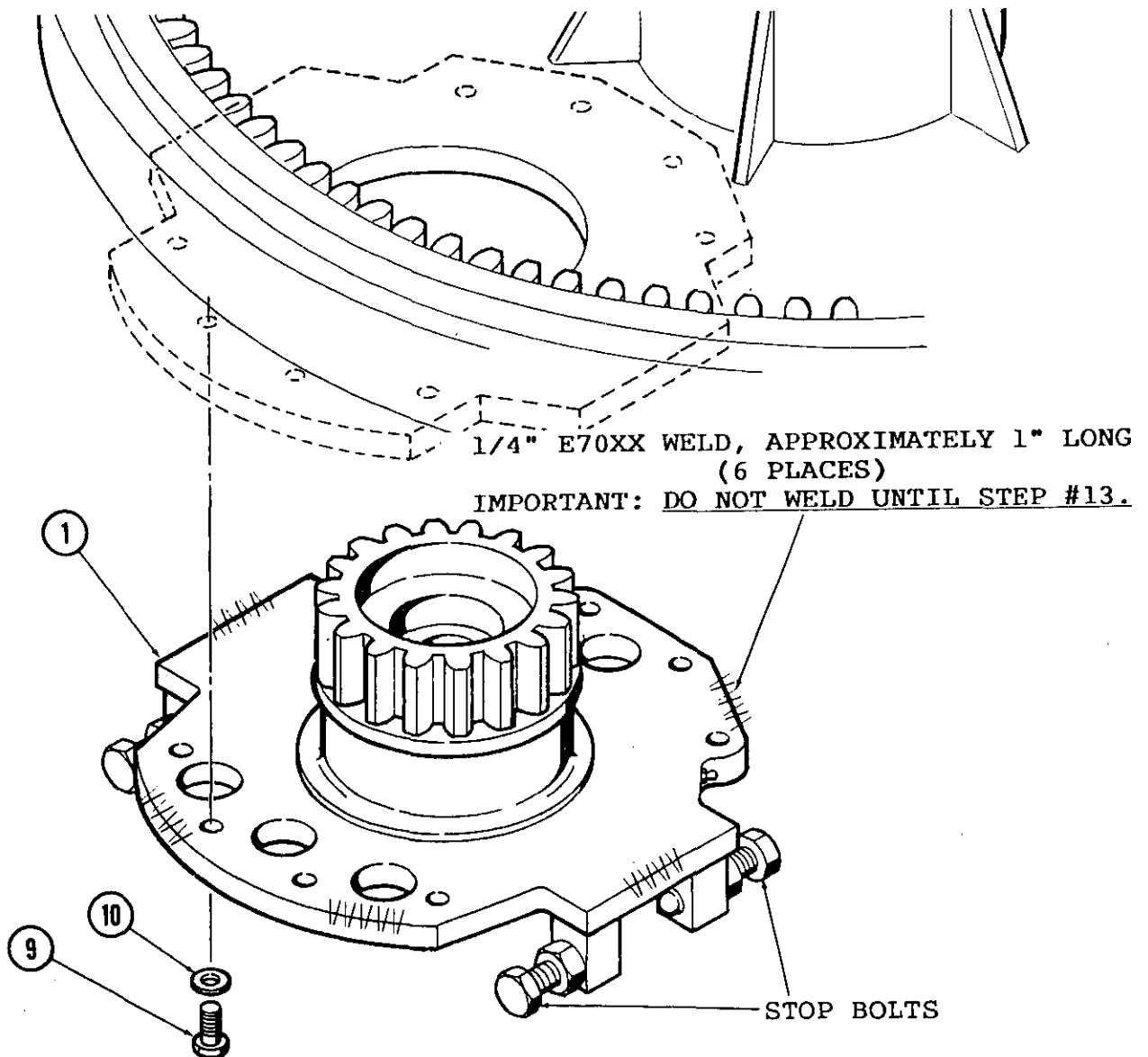

12. Adjust the mesh of the pinion gear to the ring gear by moving the mount plate as required to obtain 0.005 inch of between the teeth.
13. When the correct adjustment is obtained, tighten the four bolts to 145 ft-lbs. (5/8-11 Grade 8 bolts with hardened washer). Weld the mount plate to the frame as shown in the illustration on page 6. Weld the housing of the mount assembly to the mount plate as shown in the illustration on this page.



14. Install the motor mount (Item #2) on the motor using the existing hardware. Tighten the bolts to 185 ft-lbs. (3/4-10 Grade 5 bolts with hardened washers).

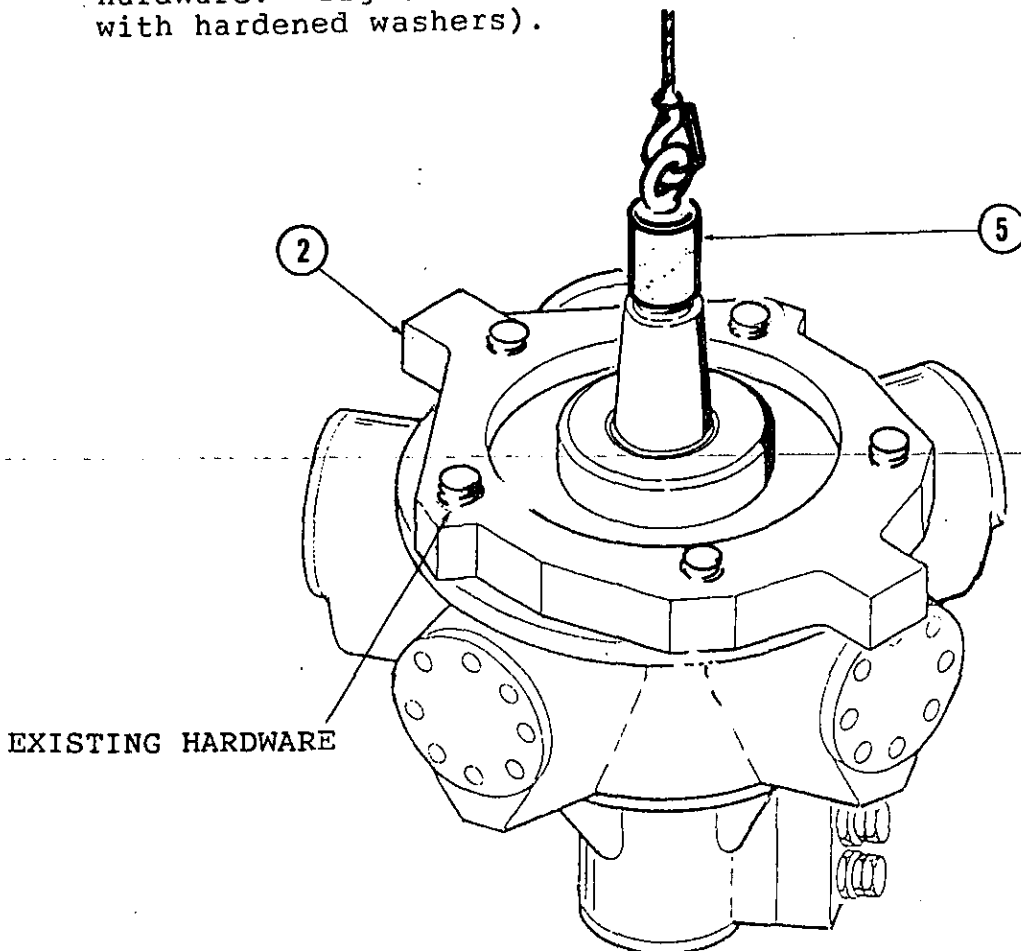

15. Install the existing key in the motor shaft keyway.
16. Install the lifting adapter (Item #5) on the hydraulic motor shaft. Attach a suitable cable or chain hoist to the lifting adapter, through the center of the pinion gear as shown on the following page.
17. Using the hoist in conjunction with the hydraulic jack, raise the motor into position. Make sure the key lines up with the keyway in the pinion.

**NOTE:** Do not attempt to raise the motor completely into position with the hoist. Raise it high enough that the lifting adapter can be removed and the special washer and pinion nut can be installed.

18. Make sure the motor is securely blocked from underneath and remove the lifting adapter.

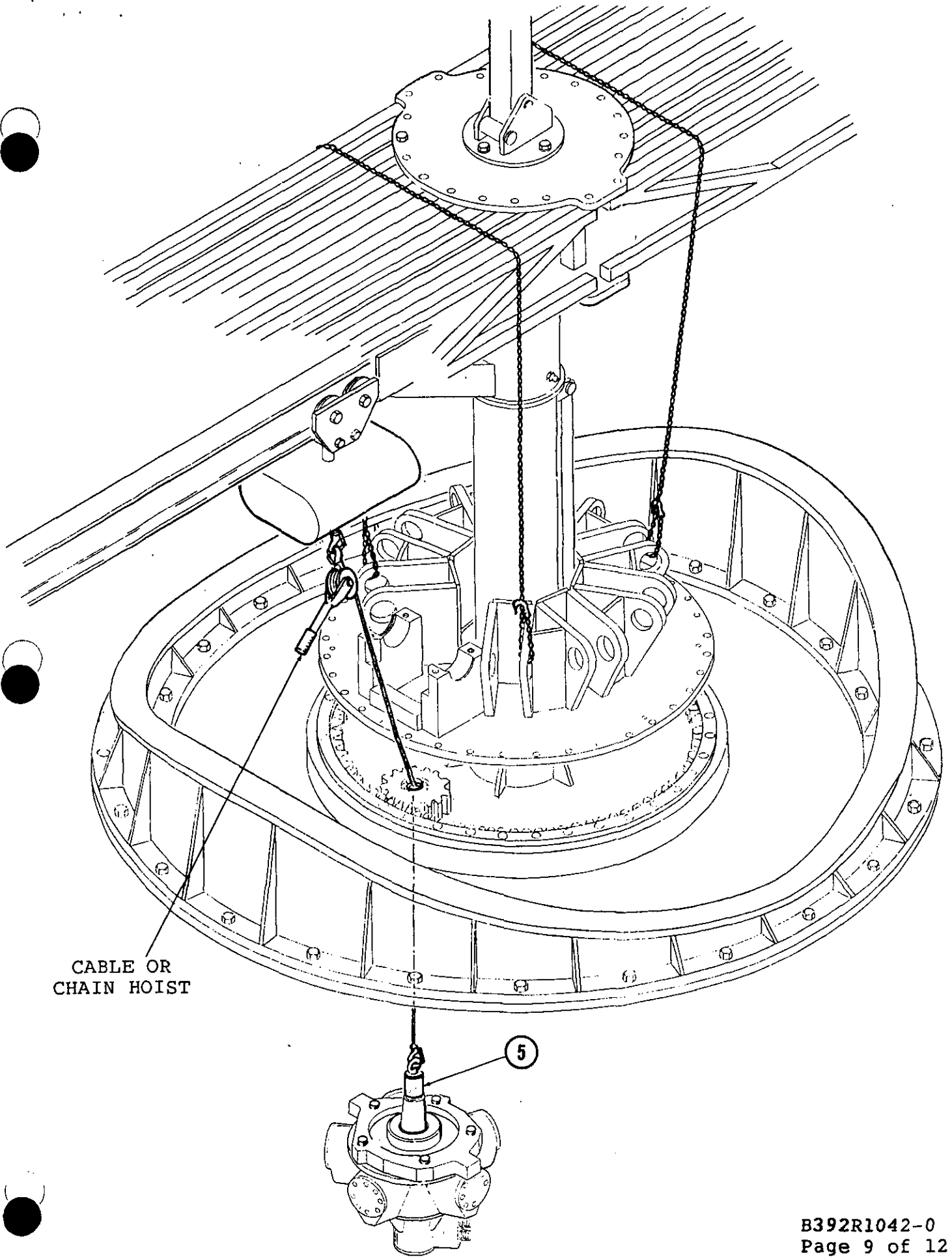

CABLE OR  
CHAIN HOIST

5

19. Install the existing special washer and new pinion nut (Item #6)

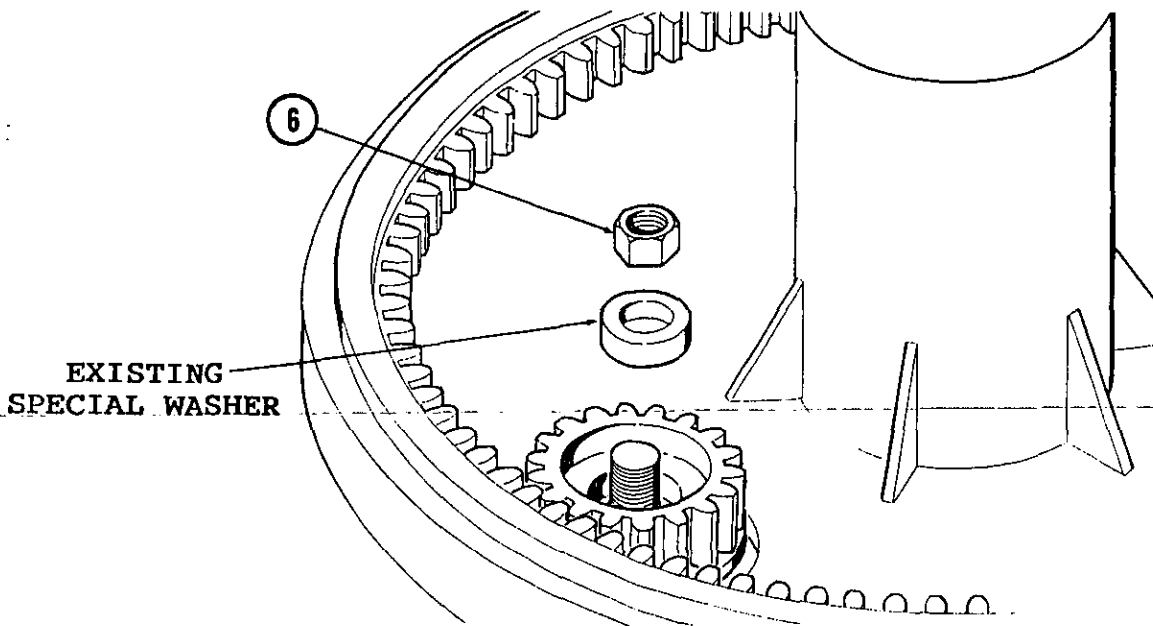

20. Tighten the nut to 700 ft-lbs. As the nut is tightened, the motor will be drawn up into position.

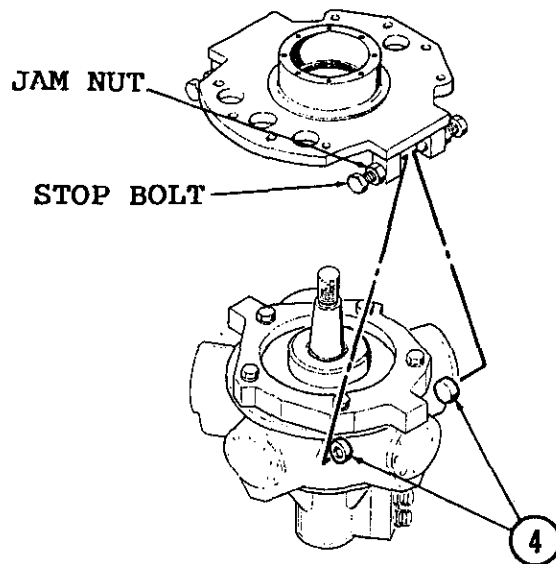

21. Tighten the four stop bolts evenly, with a pad (Item #4) installed over the spherical end of each stop bolt. Tighten the stop bolts until snug, then tighten the jam nuts.

22. Install the hydraulic hoses (Items #7 and #8).
23. Lower the center hub into position. Install the capscrews and washers and tighten to 105 ft-lbs. (5/8-11 Grade 8 capscrews with hardened washers).
24. Install all double sweeps except the master double sweep. Install the retainer shafts and tighten the capscrews to 105 ft-lbs. Install new lockwire in the capscrews.

**NOTE:** Install the shaft spacer on the side of the sweep spindle opposite the large end of the retainer shaft.

25. Install the master double sweep. Install the bearing caps, hardened washers and capscrews. Tighten the capscrews to 460 ft-lbs. (7/8-9 Grade 8 capscrews with hardened washers).
26. Install all sweeps on the double sweeps. Install and adjust the spreader bars as instructed in Service Bulletin B392R1004-A.
27. Complete the ride set-up procedure as described in the CHANCE OPERATION & MAINTENANCE MANUAL.

**IMPORTANT:** Thoroughly lubricate the bearings in the mount assembly through the grease fitting provided using No. 2 lithium base grease. The bearings must be lubricated at weekly intervals.

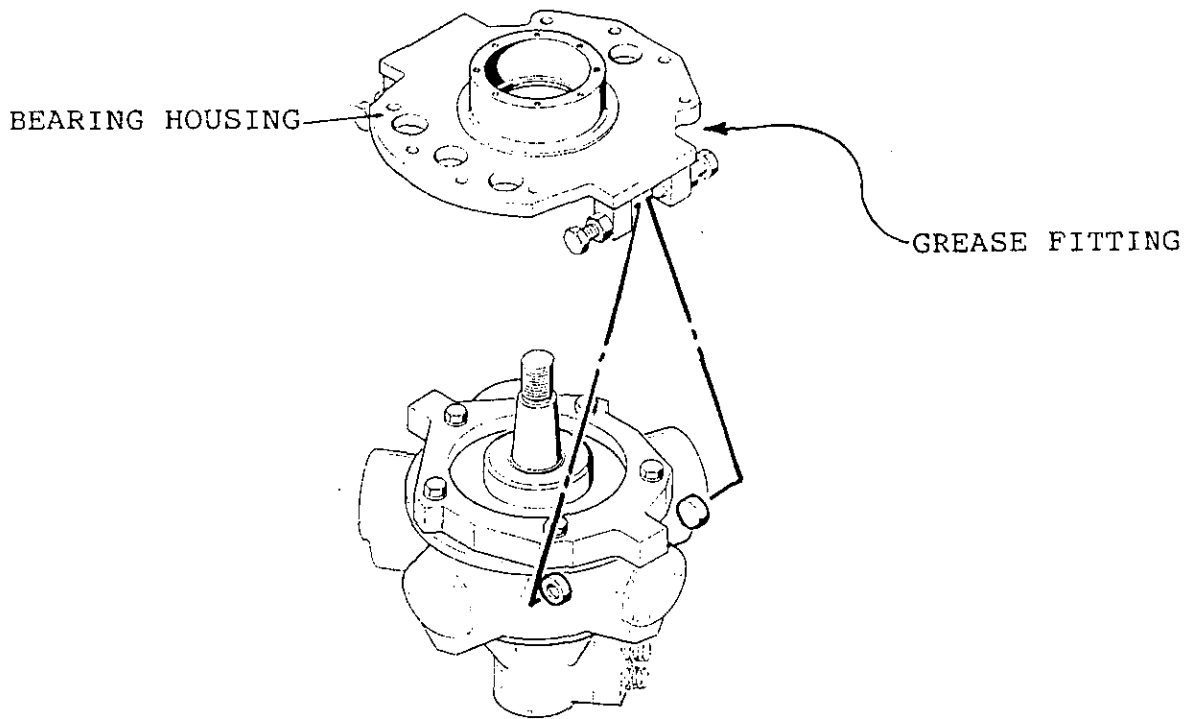

## REPLACEMENT PARTS

The 34510300 MOUNT ASSEMBLY (392-618-001)  
consists of the following parts

35242600	..PINION GEAR (392-624-001)	1
33493400	..BEARING HOUSING (392-609-001)	1
30742200	..STOP BOLT (392-621-004)	2
36451700	..SEAL - Upper (392-621-005)	1
36451600	..SEAL - Lower (392-621-002)	1
31220200	..BEARING CAP (392-621-001)	1
71395300	..SHIM - 0.003 (392-623-001)	A/R
71395400	..SHIM - 0.007 (392-623-002)	A/R
71395500	..SHIM - 0.015 (392-623-003)	A/R
290-0518001	..BEARING CUP	2
290-0446701	..BEARING CONE	2
290-6129801	..SNAP RING - External (4-1/4")	1
697-8981200	..GREASE FITTING - 45° (1/4-28)	1
691-4762800	..JAM NUT (7/8-9)	4
686-0786200	..CAPSCREW - Hex Head (3/8-16 x 1)	8
696-8553100	..WASHER - Hardened (3/8)	8

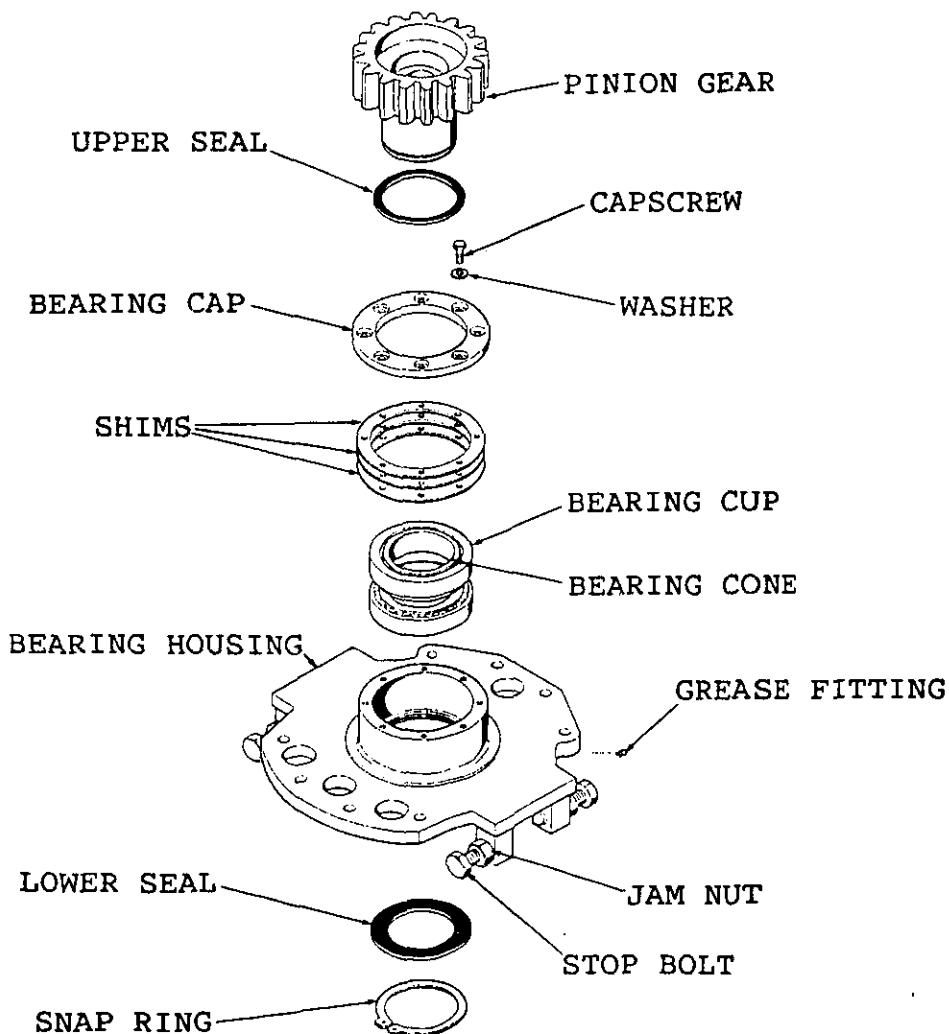



# Certification of Compliance

SERVICE BULLETIN B392R1042-0

We hereby certify the procedure outlined in the above-mentioned service bulletin has been performed on the \_\_\_\_\_  
Serial No(s) \_\_\_\_\_, in accordance with the instructions and specifications supplied by Chance Rides, Inc.

Date Bulletin Received \_\_\_\_\_

Date Procedure Performed \_\_\_\_\_

Name and Address of Person performing Procedure:

\_\_\_\_\_  
\_\_\_\_\_

**Attested:**

Owner \_\_\_\_\_

Maintenance Supervisor \_\_\_\_\_

Address \_\_\_\_\_

Address \_\_\_\_\_

City \_\_\_\_\_ State \_\_\_\_\_

City \_\_\_\_\_ State \_\_\_\_\_

By: \_\_\_\_\_

Date: \_\_\_\_\_

Date: \_\_\_\_\_

**Results:** \_\_\_\_\_  
\_\_\_\_\_  
\_\_\_\_\_  
\_\_\_\_\_

This certification must be completed and returned to Chance Rides, Inc. within fifteen (15) days of receipt of the bulletin.



Number: B392R1042-A

Date: July 28, 1989

Supersedes: B392R1042-0

---

---

## SERVICE BULLETIN

---

---

Effective Serial Numbers: 86-5308 and 392-00986 through 392-01989

Ride: THUNDERBOLT

Subject: Hydraulic Motor Mount Rework

**WARNING: FAILURE TO COMPLY WITH THIS SERVICE BULLETIN CAN RESULT IN FAILURE OF THE DRIVE MOTOR, CAUSING THE RIDE TO STOP ABRUPTLY. THIS CAN RESULT IN INJURY TO PASSENGERS.**

This bulletin supersedes Service Bulletin No. B392R1042-0. It is no longer in effect and should be destroyed.

It has been determined by CHANCE RIDES, INC. that the hydraulic drive motor shaft can fail during operation. The motor mount and pinion gear have been redesigned to reduce the load on the motor shaft.

All owners of the above noted THUNDERBOLT amusement rides are required to perform the rework described in this bulletin by January 1, 1990.

Perform the rework using the instructions on the following pages of this bulletin. Order Kit No. K392R1042-0 and install the kit using the instructions provided. All work must be performed by qualified personnel, capable of understanding the function of the parts and their proper installation.

Return the attached Certification Of Compliance no later than January 1, 1990. If there are any questions regarding the instructions or this rework, contact the CHANCE CUSTOMER SERVICE DEPARTMENT.

**PARTS LIST - Kit No. K392R1042-0,**

The following parts are included to rework one ride.

Ref. No.	Part Number	Description	Qty. Read.
1.	34510300	*MOUNT ASSEMBLY (392-618-001)	1
2.	34517006	MOTOR MOUNT (392-615-001)	1
3.	34517007	MOUNT PLATE (392-616-001)	1
4.	34946300	PAD (392-621-003)	4
5.	30122600	LIFTING ADAPTER	1
6.	64815500	NUT - Pinion (1-1/2 - 12 Flexlock)	1
7.	33476502	HOSE - Hydraulic (392-650-001)	1
8.	33476503	HOSE - Hydraulic (392-650-002)	2
9.	60910600	CAPSCREW - Grade 5 (5/8-11 x 1-3/4)	8
10.	68552900	WASHER - Hardened (5/8)	8

\* For replacement parts for the motor mount assembly, refer to drawing on page 12 of this bulletin.

**WARNING:** The hydraulic motor and its mounting components are extremely heavy. To prevent personal injury, never attempt to remove or install any parts without a jack and blocking to adequately support the parts as they are lowered or raised.



## REWORK INSTRUCTIONS

NOTE: This rework requires partial disassembly of the ride. Use the normal tear-down or set up procedures given in the CHANCE OPERATION & MAINTENANCE MANUAL when a partially disassembled ride configuration is required.

1. Remove all cars and spreader bars from the ride. Use the chain hoist to remove all sweeps from the double sweeps.
2. Use the chain hoist to support the master double sweep and remove the bearing caps. Move the double sweep out of the way.

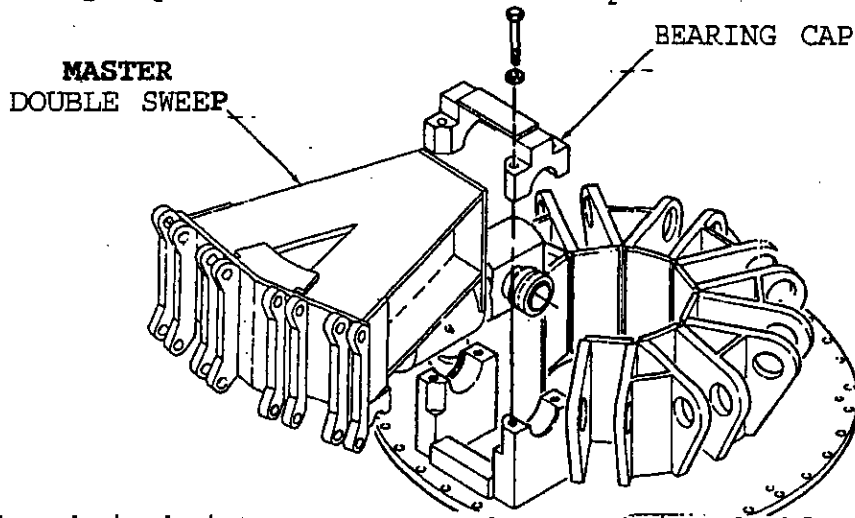

3. Use the chain hoist to remove the remaining double sweeps. Remove the sweep spindle retainer shafts and move the double sweeps out of the way.

IMPORTANT: Keep each retainer shaft with the sweep spindle from which it is removed. The double sweeps should be marked so that they are installed in their original positions.

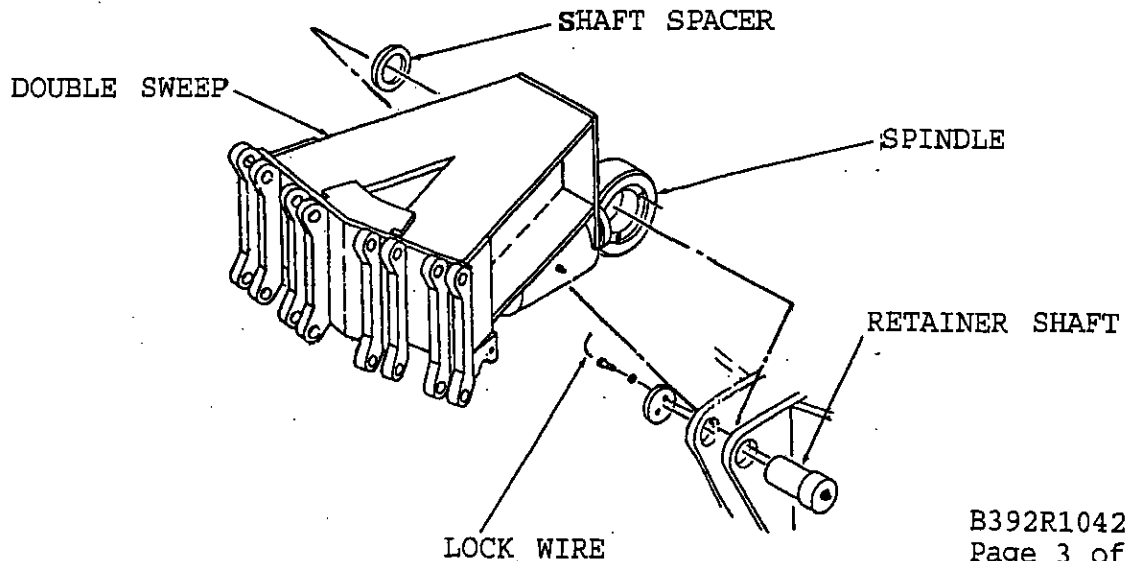

4. Remove the capscrews from the center hub.
5. With the center truss pole retracted, install chains across the trusses and attach to the center hub in four places as shown. Carefully raise the center pole, lifting the center hub. Install the safety bar.

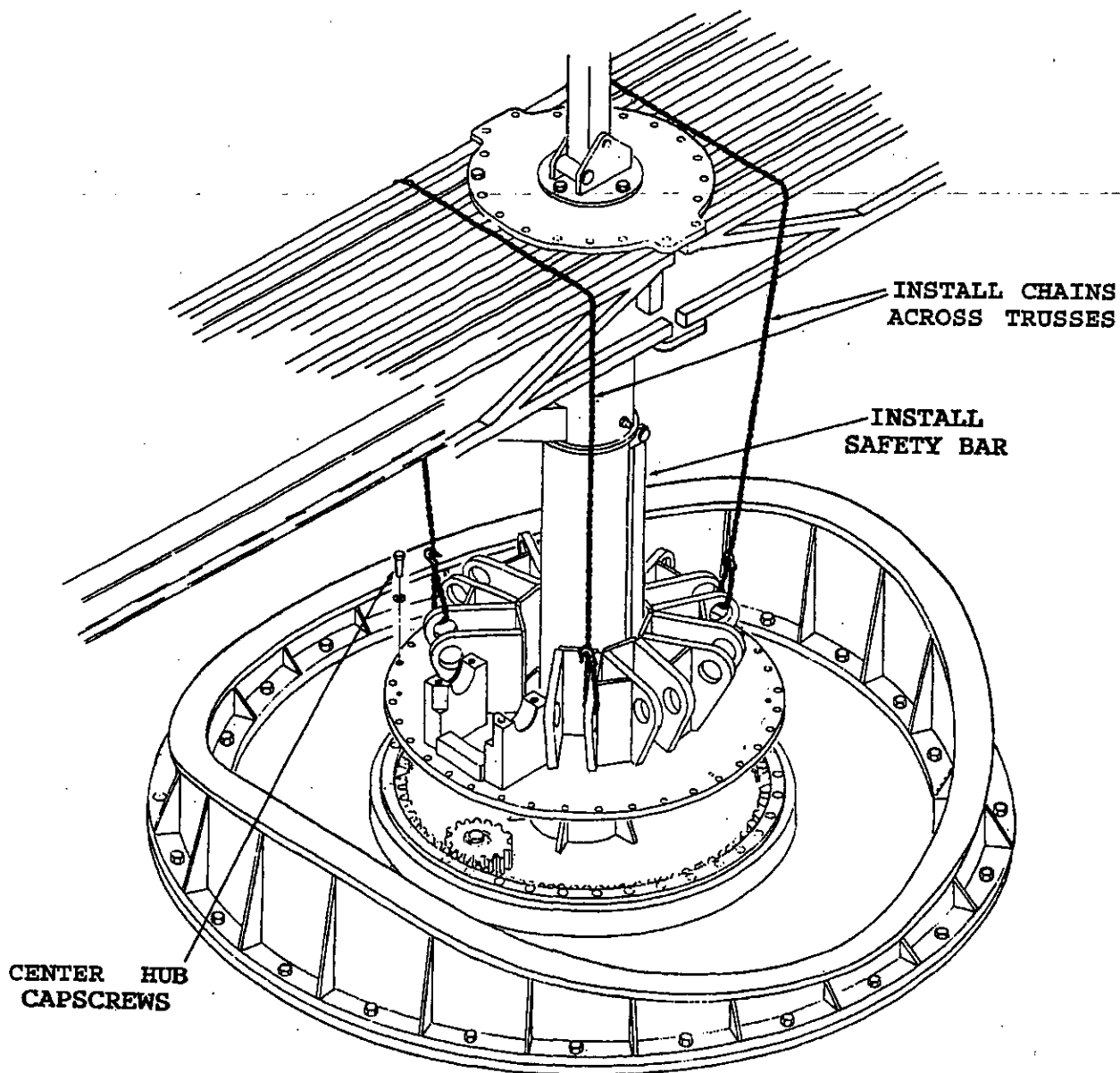

6. Remove the plumbing from the hydraulic motor. Make note of which ports are connected by each hydraulic line. These lines will be replaced with new hoses.

7. Using a hydraulic jack and blocking under the hydraulic motor, remove the five capscrews which mount the motor. Lower and remove the motor.
8. Remove the pinion nut and special washer from the motor shaft. Use a suitable puller to remove the pinion gear from the motor shaft. Return the pinion gear to the factory. Discard the nut, but save the special washer and the key.
9. Use an air/arc to remove the weld between the existing motor mount and the hub. Remove the attaching hardware and remove the motor mount. Grind the surface to remove any remaining weld.

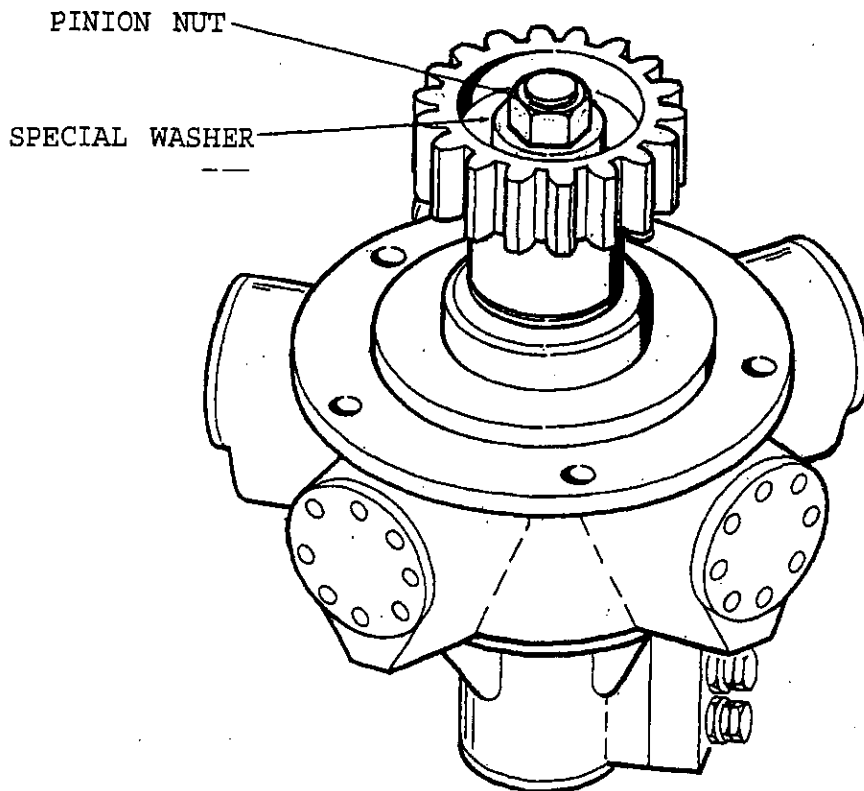
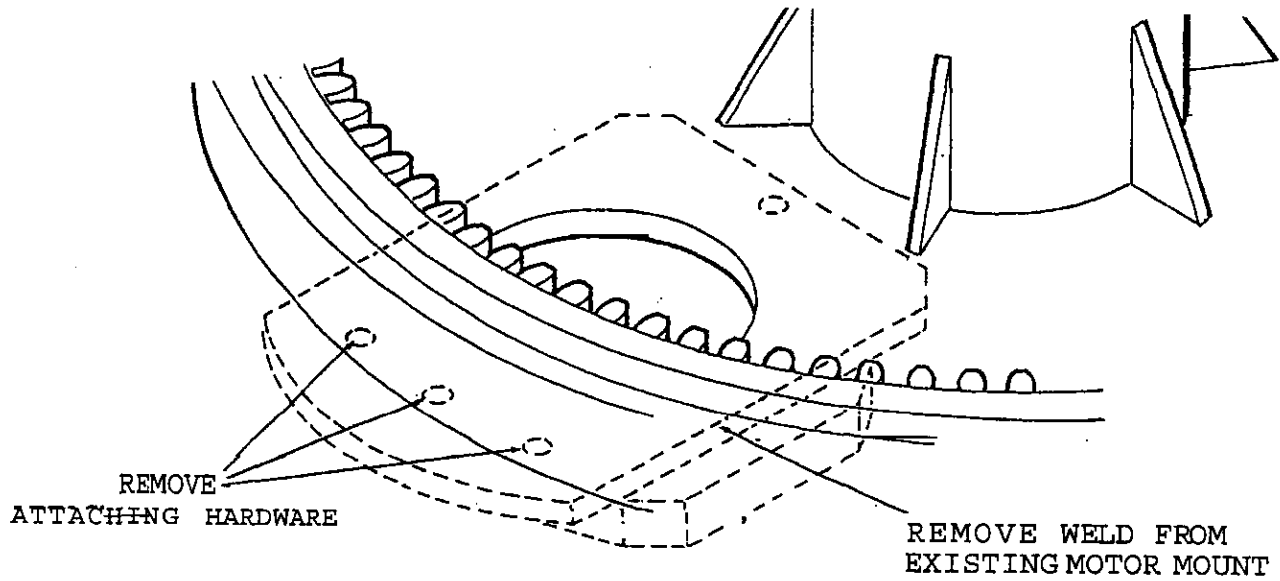

10. Install the new mount plate (Item #3) with the existing hardware, but do not tighten at this time.

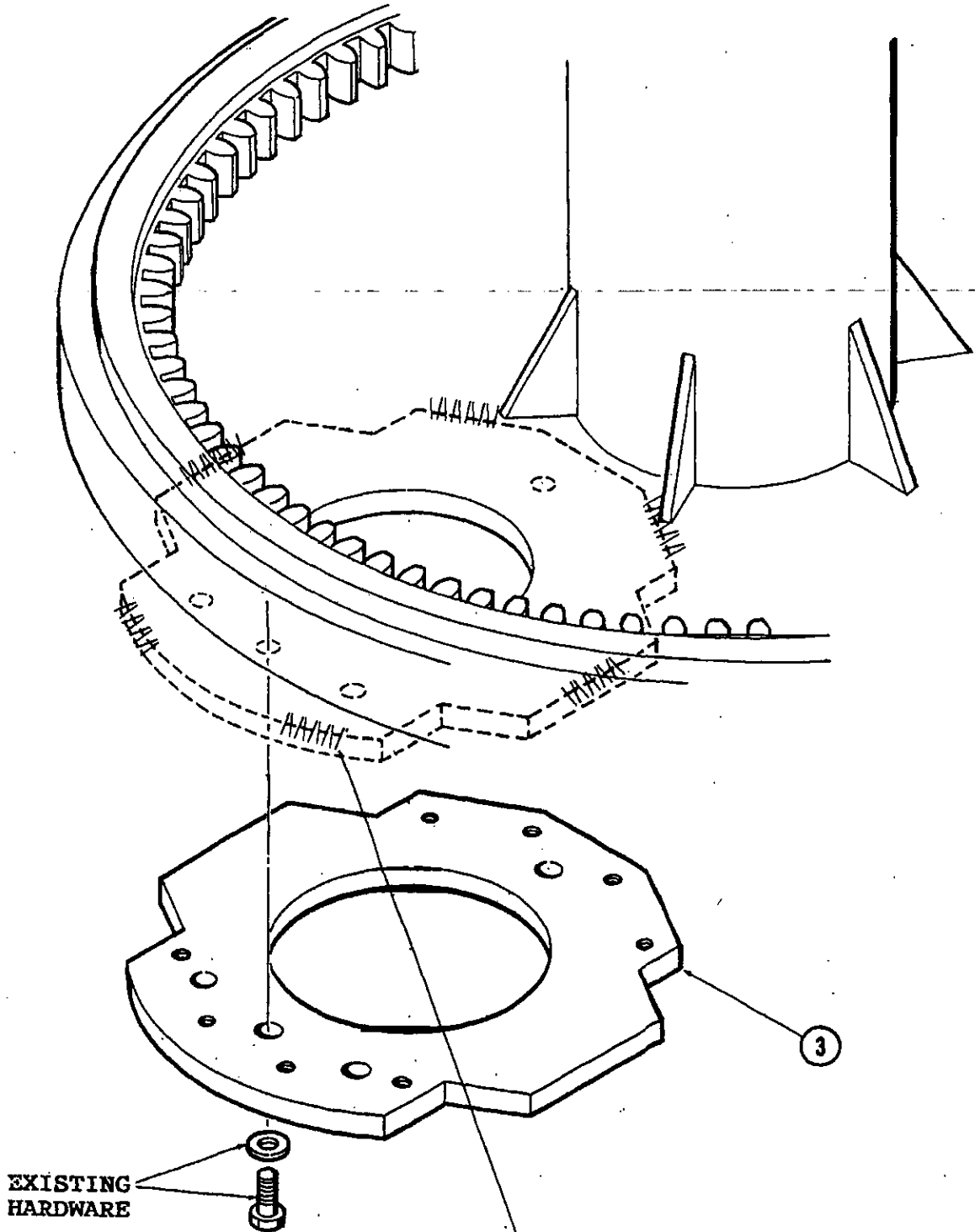

EXISTING  
HARDWARE

1/4" E70XX WELD, APPROXIMATELY 2" LONG  
(6 PLACES)  
IMPORTANT: DO NOT WELD UNTIL STEP #13.

- 11, Install the mount assembly (Item #1 to the mount plate using the capscrews and hardened washers (Items #9 and #10). Tighten the capscrews to 105 ft-lbs. (5/8-11 Grade 5 capscrews).

**IMPORTANT:** Loosen the jam nuts and turn all four stop bolts out until their spherical ends do not protrude.

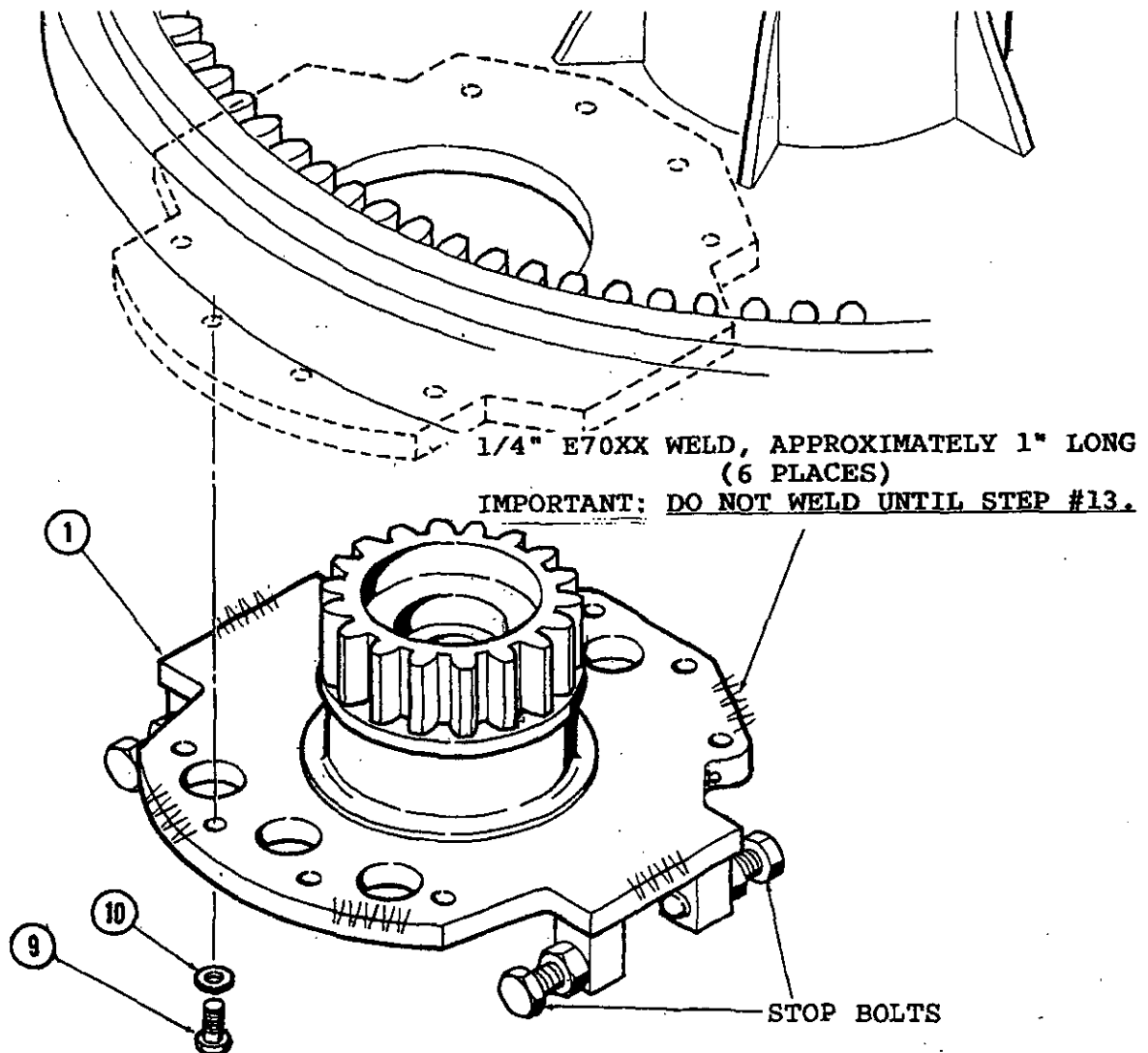

12. Adjust the mesh of the pinion gear to the ring gear by moving the mount plate as required to obtain 0.005 inch of between the teeth.
- 1.3 When the correct adjustment is obtained, tighten the four bolts to 145 ft-lbs. (5/8-11 Grade 8 bolts with hardened washer). Weld the mount plate to the frame as shown in the illustration on page 6. Weld the housing of the mount assembly to the mount plate as shown in the illustration on this page.

14. Install the motor mount (Item #2) on the motor using the existing hardware. Tighten the bolts to 185 ft-lbs. (3/4-1.0 Grade 5 bolts with hardened washers).

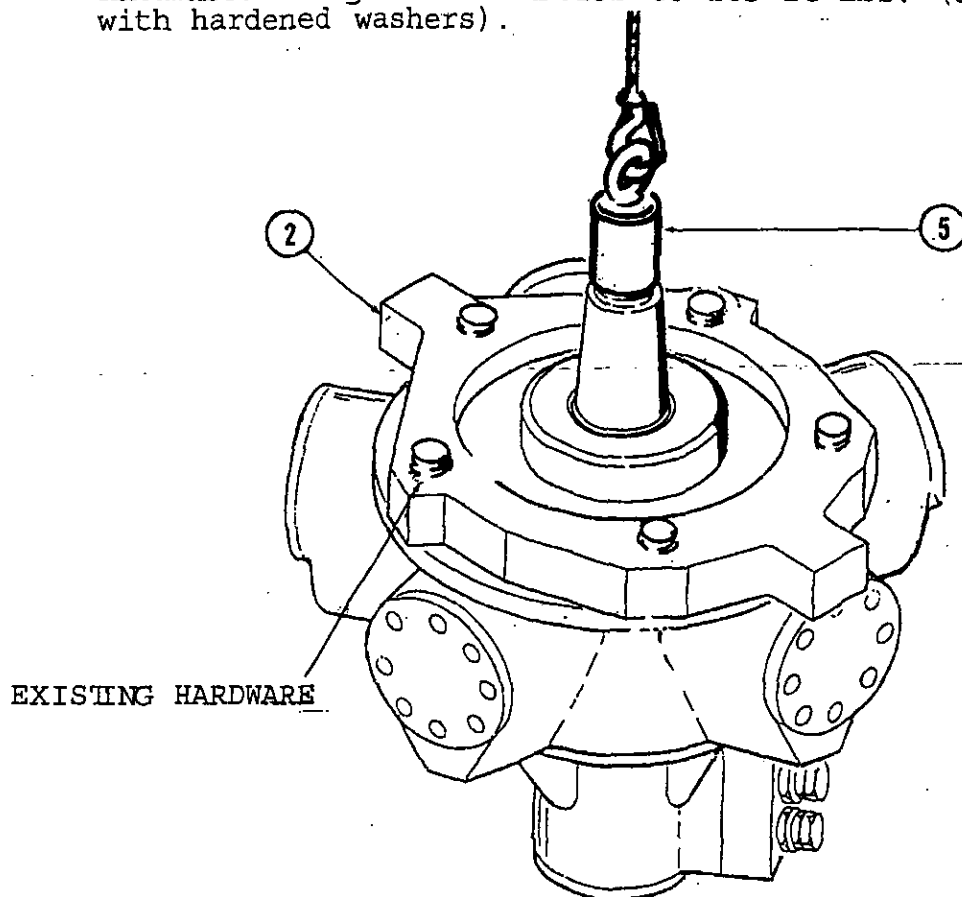

15. Install the existing key in the motor shaft keyway.
16. Install the lifting adapter (Item #5) on the hydraulic motor shaft. Attach a suitable cable or chain hoist to the lifting adapter, through the center of the pinion gear as shown on the following page.
17. Using the hoist in conjunction with the hydraulic jack, raise the motor into position. Make sure the key lines up with the keyway in the pinion.

NOTE: Do not attempt to raise the motor completely into position with the hoist. Raise it high enough that the lifting adapter can be removed and the special washer and pinion nut can be installed.

18. Make sure the motor is securely blocked from underneath and remove the lifting adapter.

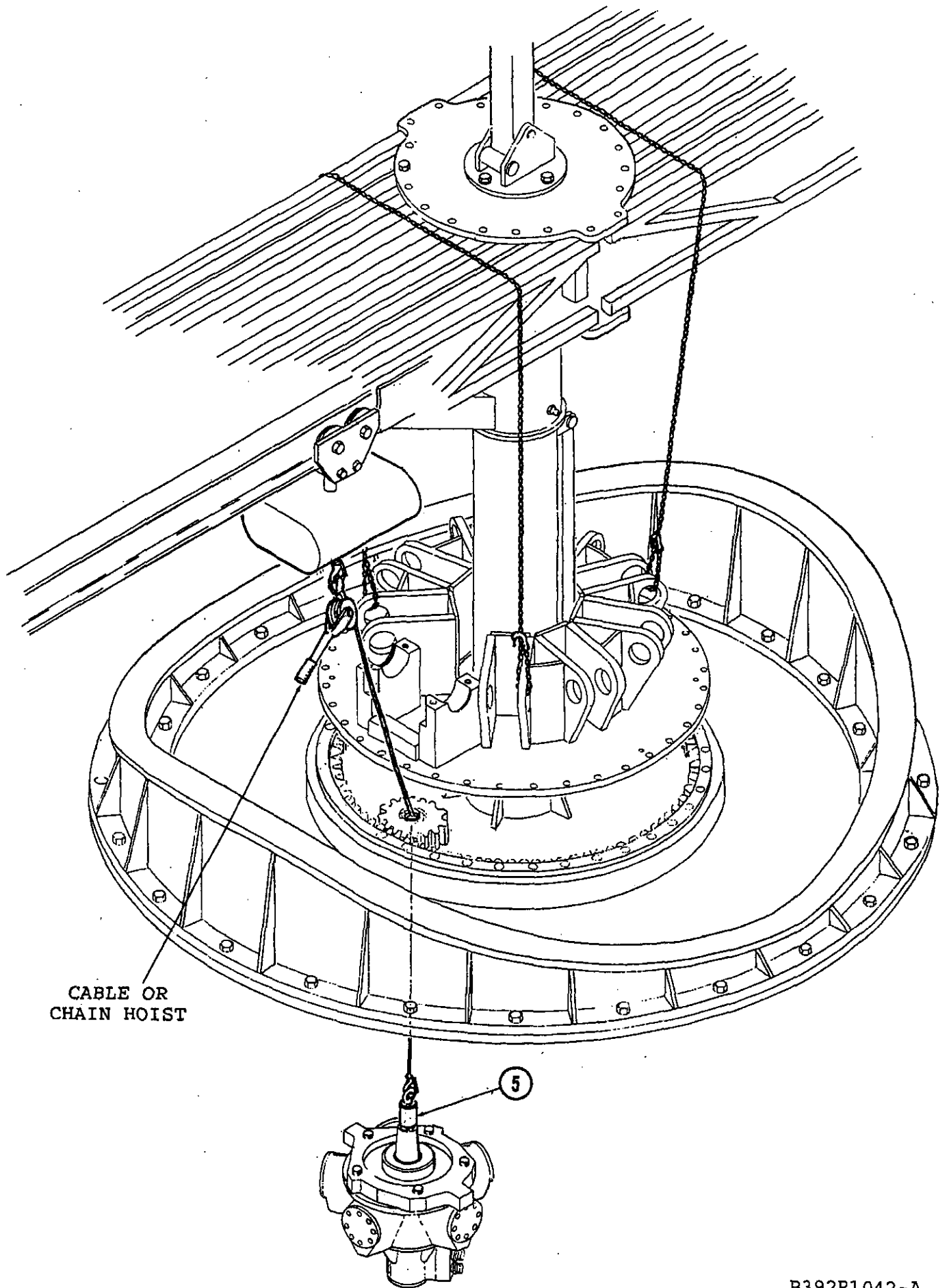

CABLE OR  
CHAIN HOIST

5

19. Install the existing special washer and new pinion nut (Item #6)

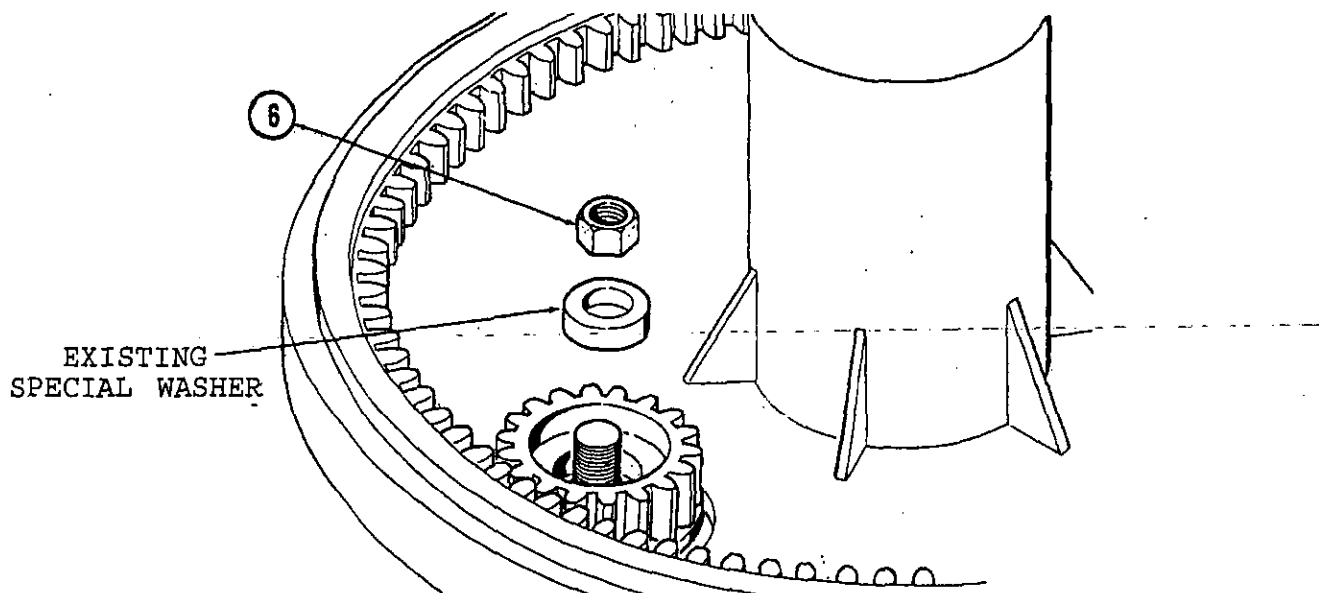

20. Tighten the nut to 700 ft-lbs. As the nut is tightened, the motor will be drawn up into position.

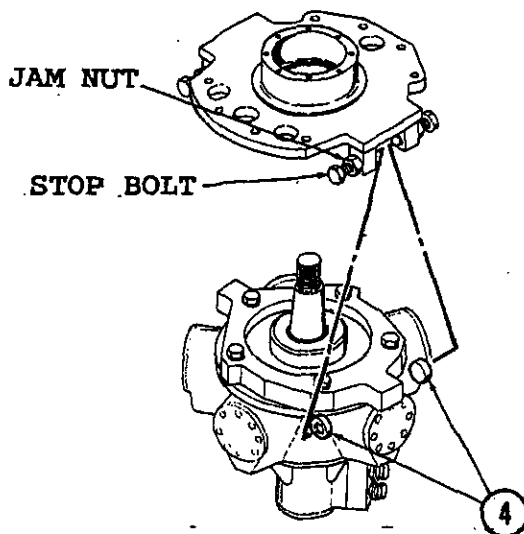

21. Tighten the four stop bolts evenly, with a pad (Item #4) installed over the spherical end of each stop bolt. Tighten the stop bolts until snug, then tighten the jam nuts.



22. Install the hydraulic hoses (Items #7 and #8).
23. Lower the center hub into position. Install the capscrews and washers and tighten to 145 ft-lbs. (5/8-11 Grade 8 capscrews with hardened washers).
24. Install all double sweeps except the master double sweep. Install the retainer shafts and tighten the capscrews to 105 ft-lbs. Install new lockwire in the capscrews.

**NOTE:** Install the shaft spacer on the side of the sweep spindle opposite the large end of the retainer shaft.

25. Install the master double sweep. Install the bearing caps, hardened washers and capscrews. Tighten the capscrews to 460 ft-lbs. (7/8-9 Grade 8 capscrews with hardened washers).
26. Install all sweeps on the double sweeps. Install and adjust the spreader bars as instructed in Service Bulletin B392R1004-A.
27. Complete the ride set-up procedure as described in the CHANCE OPERATION & MAINTENANCE MANUAL.

**IMPORTANT:** Thoroughly lubricate the bearings in the mount assembly through the grease fitting provided using No. 2 lithium base grease. The bearings must be lubricated at weekly intervals.

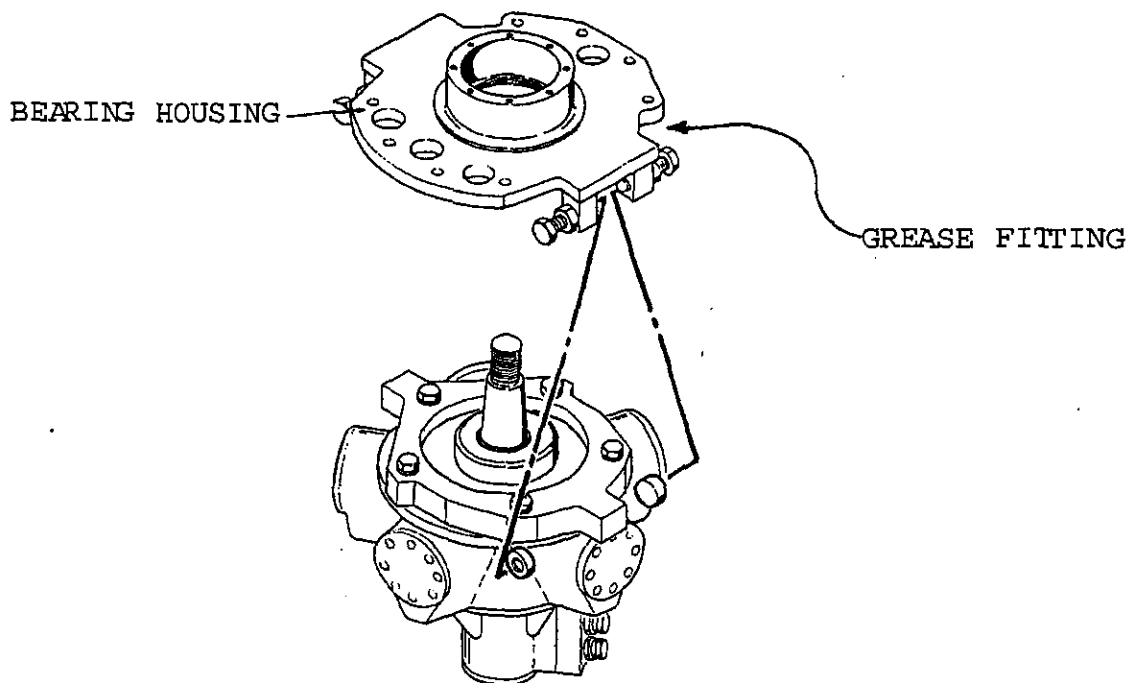

## REPLACEMENT PARTS

The 34510300 MOUNT ASSEMBLY (392-618-001)  
consists of the following parts

35242600	..PINION GEAR (392-624-001)	1
33493400	..BEARING HOUSING (392-609-001)	1
30742200	..STOP BOLT (392-621-004)	2
36451700	..SEAL - Upper (392-621-005)	1
36451600	..SEAL - Lower (392-621-002)	1
31220200	..BEARING CAP (392-621-001)	1
71395300	..SHIM - 0.003 (392-623-001)	A/R
71395400	..SHIM - 0.007 (392-623-002)	A/R
71395500	..SHIM - 0.015 (392-623-003)	A/R
290-0518001	..BEARINGCUP	2
290-0446701	..BEARING CONE	2
290-6129801	..SNAP RING - External (4-1/4")	1
697-8981200	..GREASE FITTING - 45" (1/4-28)	1
691-4762800	..JAM NUT (7/8-9)	4
686-0786200	..CAPSCREW - Hex Head (3/8-16 x 1)	8
696-8553100	..WASHER - Hardened (3/8)	8

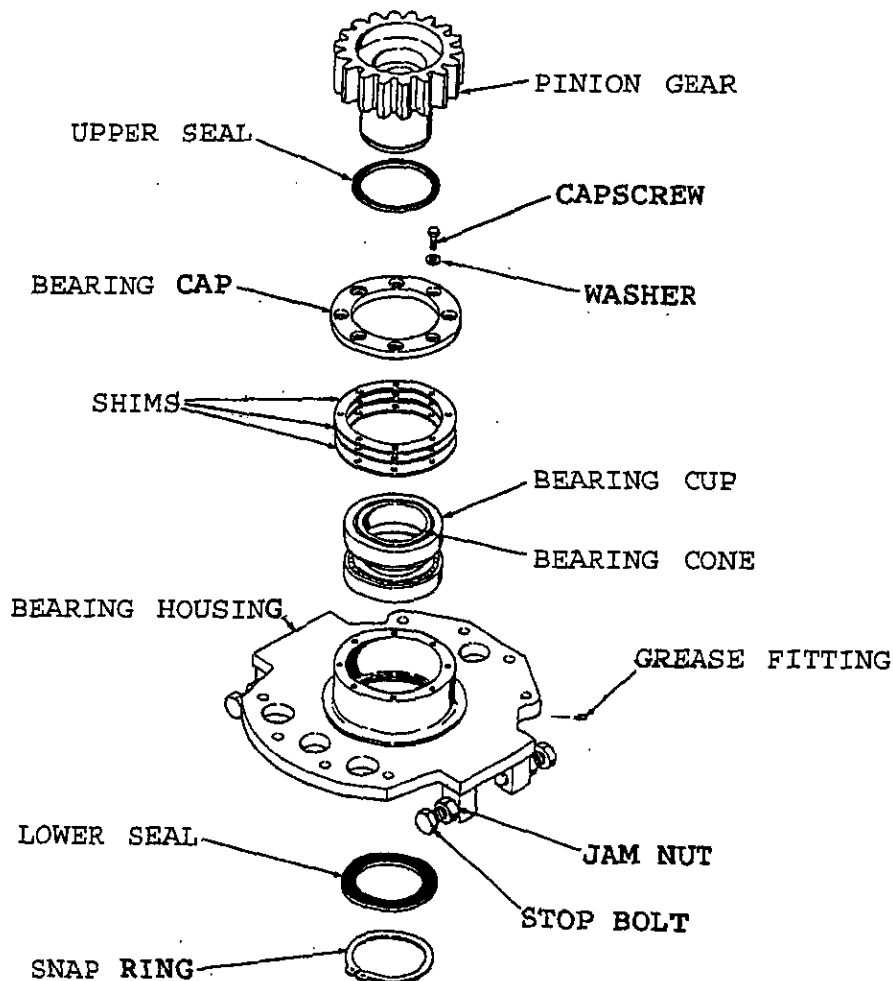



NUMBER: B392R1066-0

DATE: May 22, 1990

SUPERSEDES:

---

---

## SERVICE BULLETIN

---

---

Effective Serial Number: All Units - Chance Rides, Inc.  
All Units - Chance Manufacturing Co., Inc.

Chance Rides, Inc. SPECIFICALLY DISCLAIMS ANY  
LIABILITY for losses associated with rides  
produced by Chance Manufacturing Company, Inc.

Ride: THUNDERBOLT

Subject: Sweep Bars

Chance Rides, Inc. requires all owners of THUNDERBOLT amusement rides to inspect the ears on the sweeps and on the double sweeps for cracks as shown in the illustration on this bulletin. If the ears crack, failure of the part could occur, resulting in injury to passengers.

If any cracks are found, do not attempt to repair, contact Chance Rides Customer Service Department immediately for replacement parts. Do not operate ride until the Chance Rides, Inc. approved repair has been complete.

All work must be performed by qualified personnel, capable of understanding the function of the parts and their proper installation.

### NOTICE

Use only those components authorized, specified or provided by Chance Rides, Inc.

Chance Rides, Inc. SPECIFICALLY DISCLAIMS ANY LIABILITY for losses associated with any unauthorized alterations and/or modifications or additions and installations of unauthorized components.

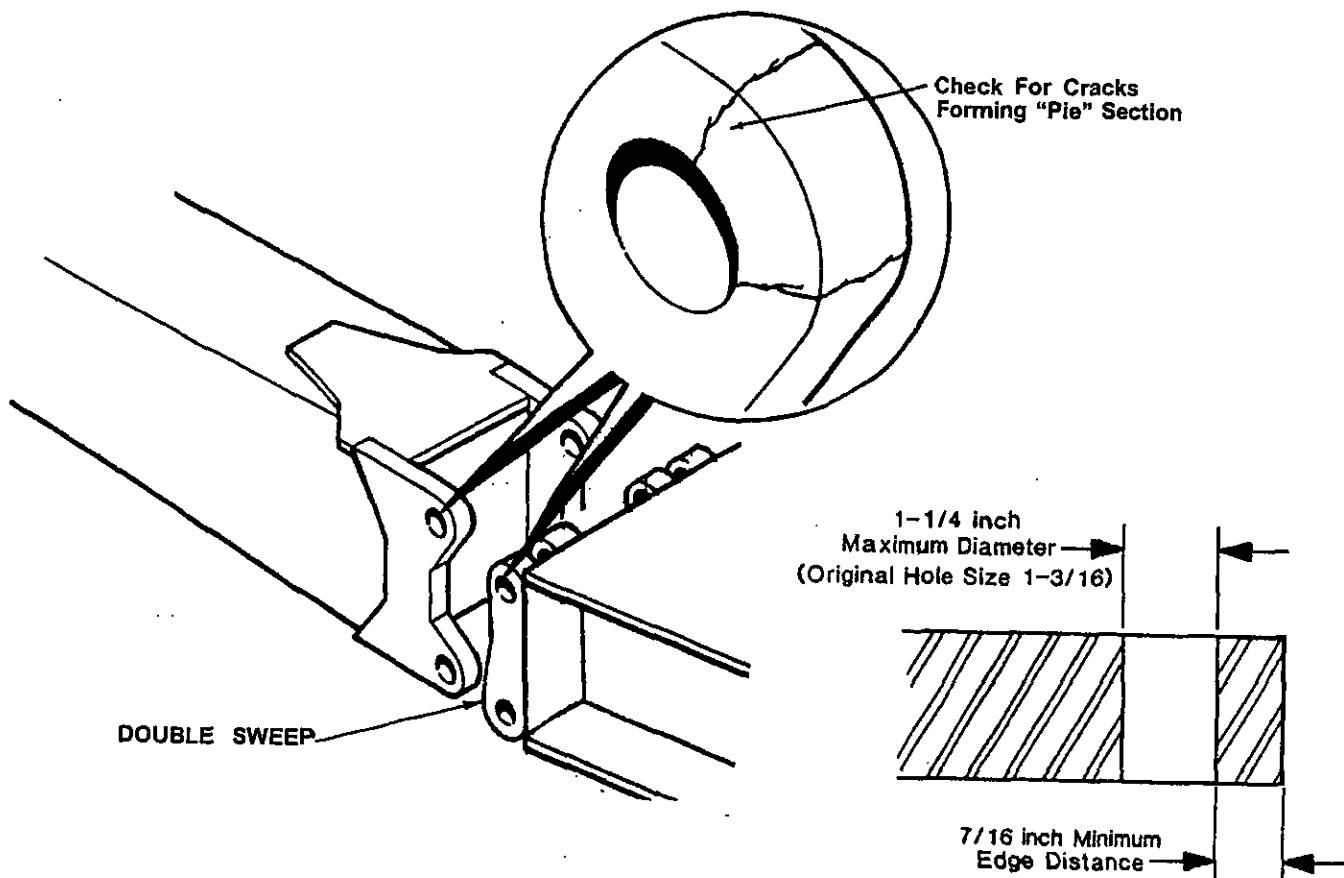



NUMBER: B392R1089-0

DATE: DEC. 15, 1990

SUPERSEDES:

---

---

## SERVICE BULLETIN

---

---

Effective Serial Number: All Units - Chance Rides, Inc.

All Units - Chance Manufacturing Co., Inc.

Chance Rides, Inc. SPECIFICALLY DISCLAIMS ANY LIABILITY for losses associated with rides produced by Chance Manufacturing Company, Inc.

Ride: THUNDERBOLT

Subject: Double Sweep Inspection

Chance Rides, Inc. requires all owners of THUNDERBOLT amusement rides to inspect the double sweeps for cracks around the bearing housing support plates. Inspection must be done as shown in the illustration on this bulletin. If the plate cracks, failure of the part could occur, resulting in possible injury to passengers.

If any cracks are found, contact the Chance Rides Customer Service Department. DO NOT ATTEMPT TO REPAIR OR WELD. DO NOT OPERATE the ride until the Chance Rides, Inc. approved repair rework kit number K392R1089-0 has been properly installed. If no cracks are found during inspection, the kit is not required.

All work must be performed by qualified personnel, capable of understanding the function of the parts and their proper installation.

### NOTICE

Use only those components authorized, specified or provided by Chance Rides, Inc.

Chance Rides! Inc. SPECIFICALLY DISCLAIMS ANY LIABILITY for losses associated with any unauthorized alterations and/or modifications or additions and installations of unauthorized components.

## INSPECTION PROCEDURES

1. Thoroughly clean all areas to be inspected. All areas must be free of grease and other foreign materials which could hamper inspection.
2. Visually inspect all areas as indicated on the illustration below.
3. This inspection must be done every 30 days or at each set up, whichever occurs first.

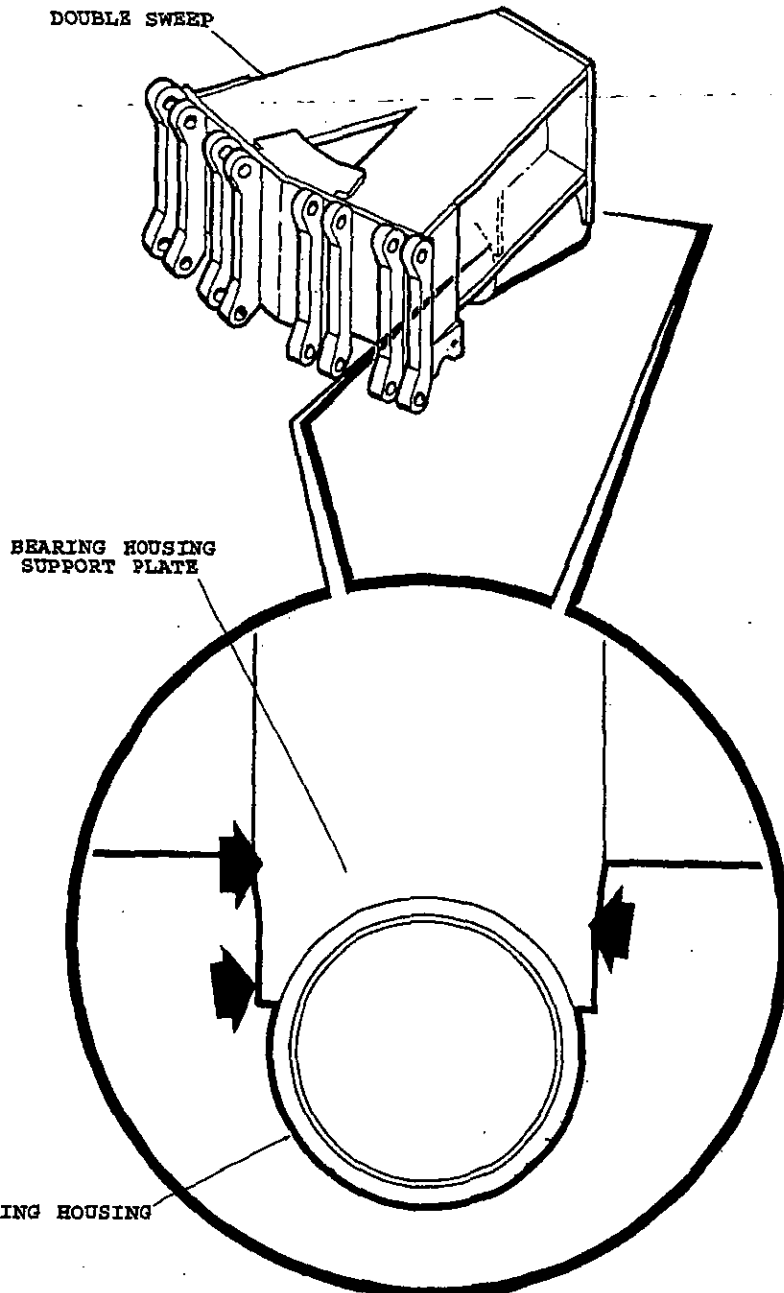



NUMBER: B392R1091-0

DATE: FEB. 28, 1991

SUPERSEDES:

---

---

## SERVICE BULLETIN

---

---

Effective Serial Number: All Units - Chance Rides, Inc.

All Units - Chance Manufacturing Co., Inc.

Chance Rides, Inc. SPECIFICALLY DISCLAIMS ANY LIABILITY for losses associated with rides produced by Chance Manufacturing Company, Inc.

Ride: THUNDERBOLT

Subject: Load/Unload Safety Decal

Chance Rides, Inc. has become aware that the vehicles on the THUNDERBOLT amusement ride may suddenly swing or shift while passengers are loading or unloading. This swing or shift is due to the passenger's weight on one side of the vehicle, placing the vehicle in an out-of-balance condition. ALL OPERATORS MUST VERBALLY CAUTION PERSONS OF POSSIBLE VEHICLE MOVEMENT AS THEY ENTER AND EXIT FROM THE VEHICLES.

A safety decal has been developed to help alert persons of possible vehicle movement as they enter and exit the vehicle. Chance Rides, Inc. requires all owner/operators of THUNDERBOLT rides to order and install one of these safety decals on each of the vehicles. A total of 18 decals are required for one ride. Order part number 22198506 and install as shown on this bulletin.

Complete the attached Certification Of Compliance and return it to Chance Rides, Inc. within fifteen (15) days from the receipt of the decals.

All work must be performed by qualified personnel, capable of understanding the function of the parts and their proper installation.

### NOTICE

Use only those components authorized, specified or provided by Chance Rides, Inc.

Chance Rides, Inc. SPECIFICALLY DISCLAIMS ANY LIABILITY for losses associated with any unauthorized alterations and/or modifications or additions and installations of unauthorized components.

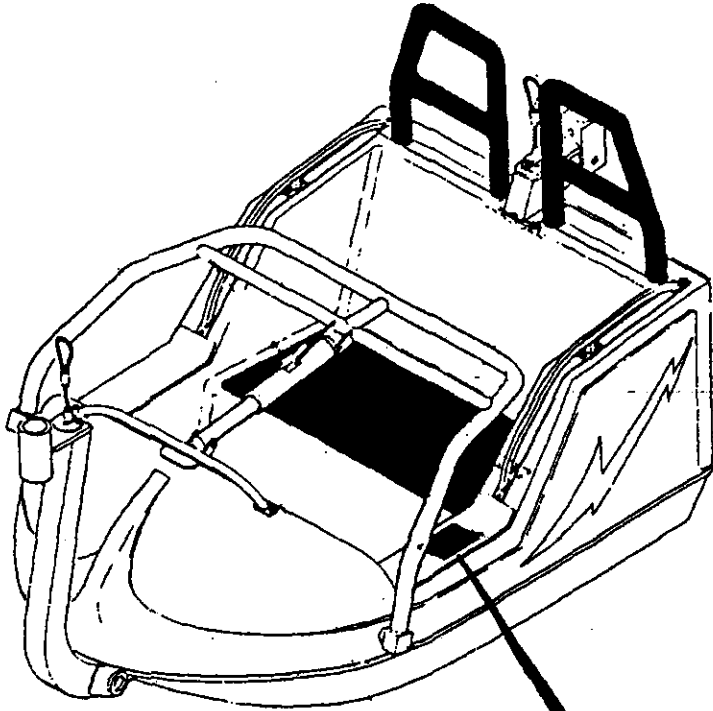

**CAUTION**

**VEHICLE MAY SWING  
WHILE ENTERING  
OR EXITING**