



Number: B37-0348-00

Date: July 12, 1989

Supersedes:

America's Largest Manufacturer of Amusement Rides

SERVICE BULLETIN

Effective Serial Numbers: 86-27066 and 85-53001 through 85-53007

Ride: THUNDERBOLT / MUSIC FEST Subject: Hydraulic Motor Mount Rework



WARNING: FAILURE TO COMPLY WITH THIS SERVICE BULLETIN CAN RESULT IN FAILURE OF THE DRIVE MOTOR, CAUSING THE RIDE TO STOP ABRUPTLY. THIS CAN RESULT IN INJURY TO PASSENGERS.

It has been determined by CHANCE MANUFACTURING CO., INC. that the hydraulic drive motor shaft can fail during operation. The motor mount and pinion gear have been redesigned to reduce the load on the motor shaft.

All owners of the above noted THUNDERBOLT and MUSIC FEST amusement rides are required to perform the rework described in this bulletin.

Perform the rework using the instructions on the following pages of this bulletin. Order Kit No. K392R1042-0 and install the kit using the instructions provided. All work must be performed by qualified personnel, capable of understanding the function of the parts and their proper installation.

Return the attached Certification Of Compliance within 15 days from receipt of the bulletin. If there are any questions regarding the instructions or this inspection, contact the CHANCE CUSTOMER SERVICE DEPARTMENT.

Factory and Sales Office: 4219 Irving • P.O. Box 12328 • Wichita, Kansas 67277 • (316) 942-7411

PARTS LIST - Kit No. K392R1042-0,
 The following parts are included to rework one ride.

Ref. No.	Part Number	Description	Qty. Reqd.
1.	34510300	*MOUNT ASSEMBLY (392-618-001)	1
2.	34517006	MOTOR MOUNT (392-615-001)	1
3.	34517007	MOUNT PLATE (392-616-001)	1
4.	34946300	PAD (392-621-003)	4
5.	--	LIFTING ADAPTER	1
6.	64806900	NUT - Pinion (1-1/2 - 12 Flexlock)	1
7.	33476502	HOSE - Hydraulic (392-650-001)	1
8.	33476503	HOSE - Hydraulic (392-650-002)	2
9.	60910600	CAPSCREW - Grade 5 (5/8-11 x 1-3/4)	8
10.	68552900	WASHER - Hardened (5/8)	8

* For replacement parts for the motor mount assembly, refer to drawing on page 12 of this bulletin.



WARNING: The hydraulic motor and its mounting components are extremely heavy. To prevent personal injury, never attempt to remove or install any parts without a jack and blocking to adequately support the parts as they are lowered or raised.

REWORK INSTRUCTIONS

NOTE: This rework requires partial disassembly of the ride. Use the normal tear-down or set up procedures given in the CHANCE OPERATION & MAINTENANCE MANUAL when a partially disassembled ride configuration is required.

1. Remove all cars and spreader bars from the ride. Use the chain hoist to remove all sweeps from the double sweeps.
2. Use the chain hoist to support the master double sweep and remove the bearing caps. Move the double sweep out of the way.

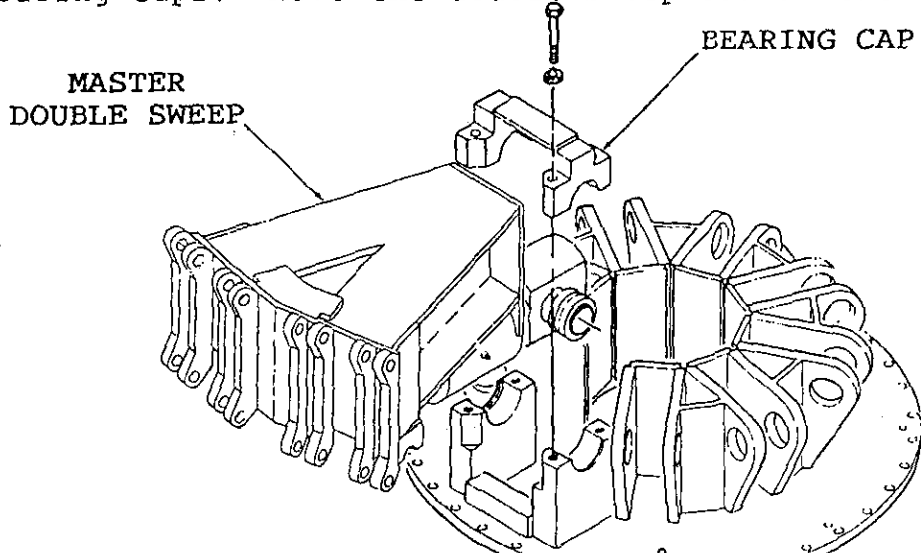

3. Use the chain hoist to remove the remaining double sweeps. Remove the sweep spindle retainer shafts and move the double sweeps out of the way.

IMPORTANT: Keep each retainer shaft with the sweep spindle from which it is removed. The double sweeps should be marked so that they are installed in their original positions.

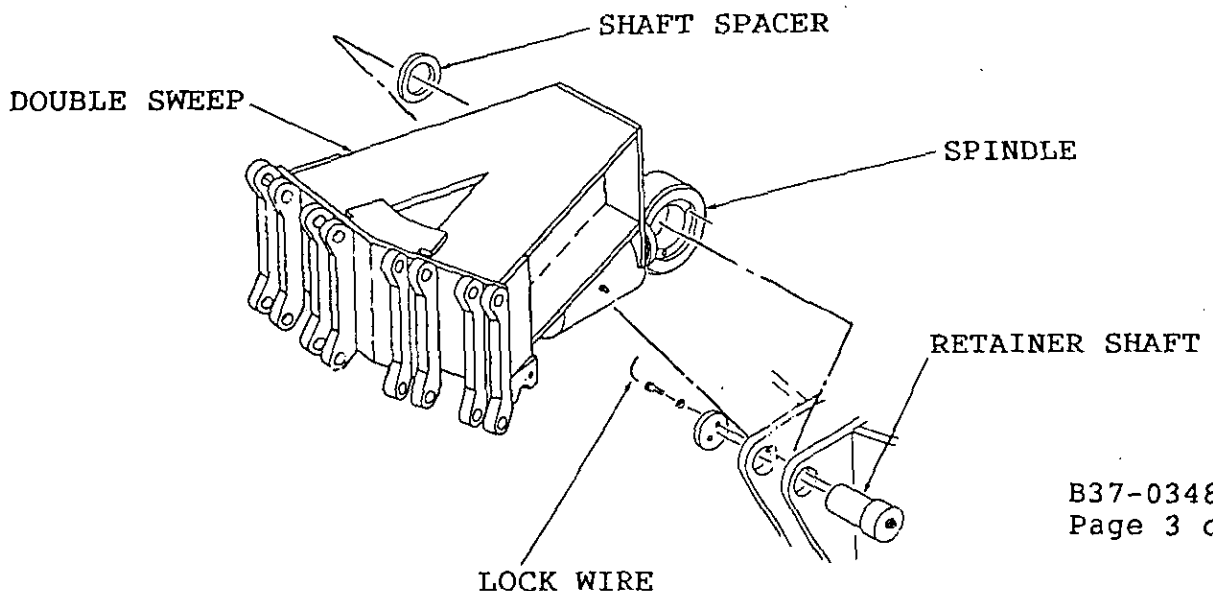

4. Remove the capscrews from the center hub.
5. With the center truss pole retracted, install chains across the trusses and attach to the center hub in four places as shown. Carefully raise the center pole, lifting the center hub. Install the safety bar.

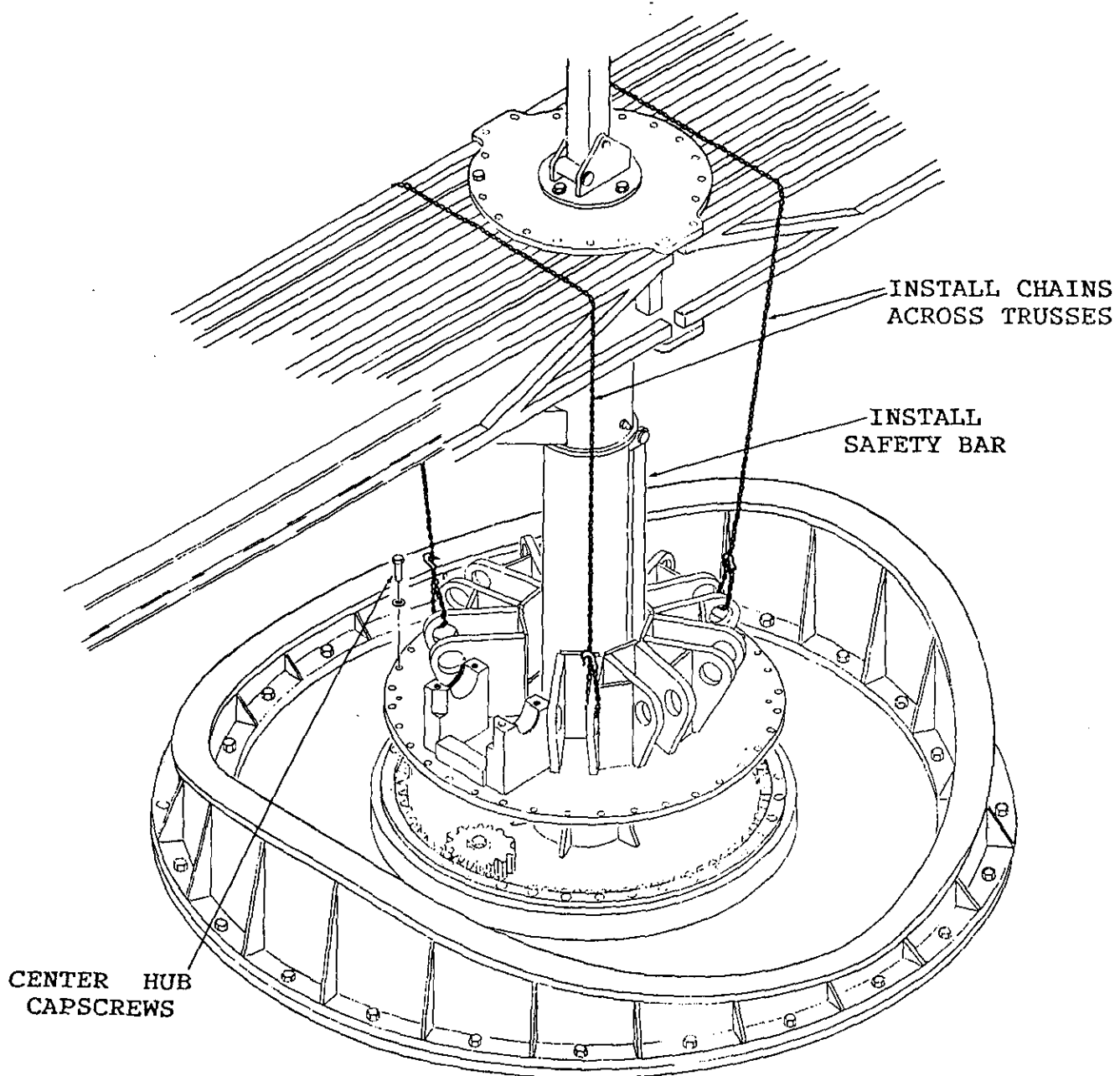

6. Remove the plumbing from the hydraulic motor. Make note of which ports are connected by each hydraulic line. These lines will be replaced with new hoses.

7. Using a hydraulic jack and blocking under the hydraulic motor, remove the five capscrews which mount the motor. Lower and remove the motor.
8. Remove the pinion nut and special washer from the motor shaft. Use a suitable puller to remove the pinion gear from the motor shaft. Return the pinion gear to the factory. Discard the nut, but save the special washer and the key.
9. Use an air/arc to remove the weld between the existing motor mount and the hub. Remove the attaching hardware and remove the motor mount. Grind the surface to remove any remaining weld.

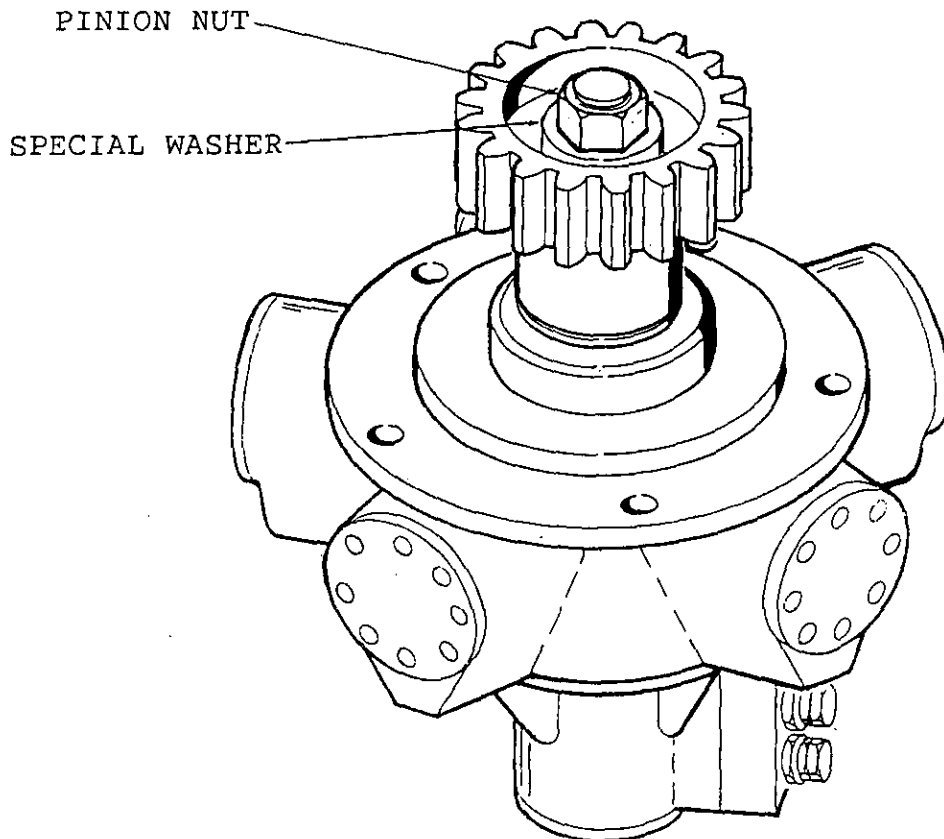
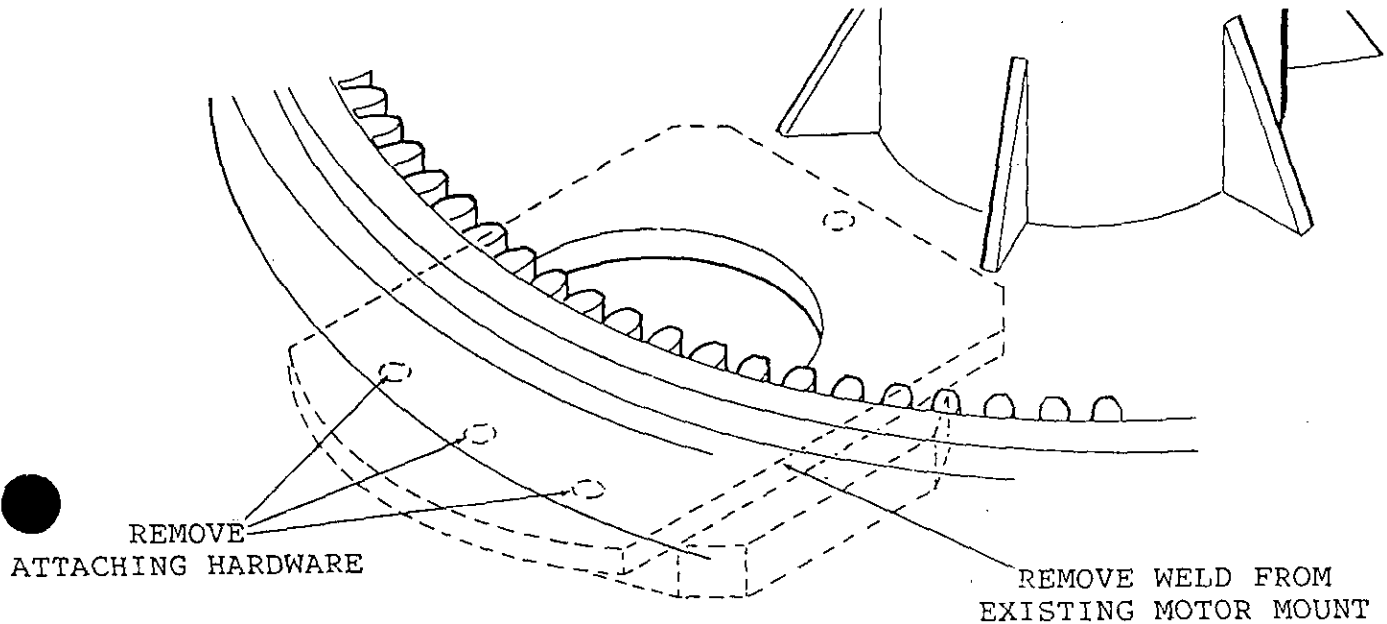

10. Install the new mount plate (Item #3) with the existing hardware, but do not tighten at this time.

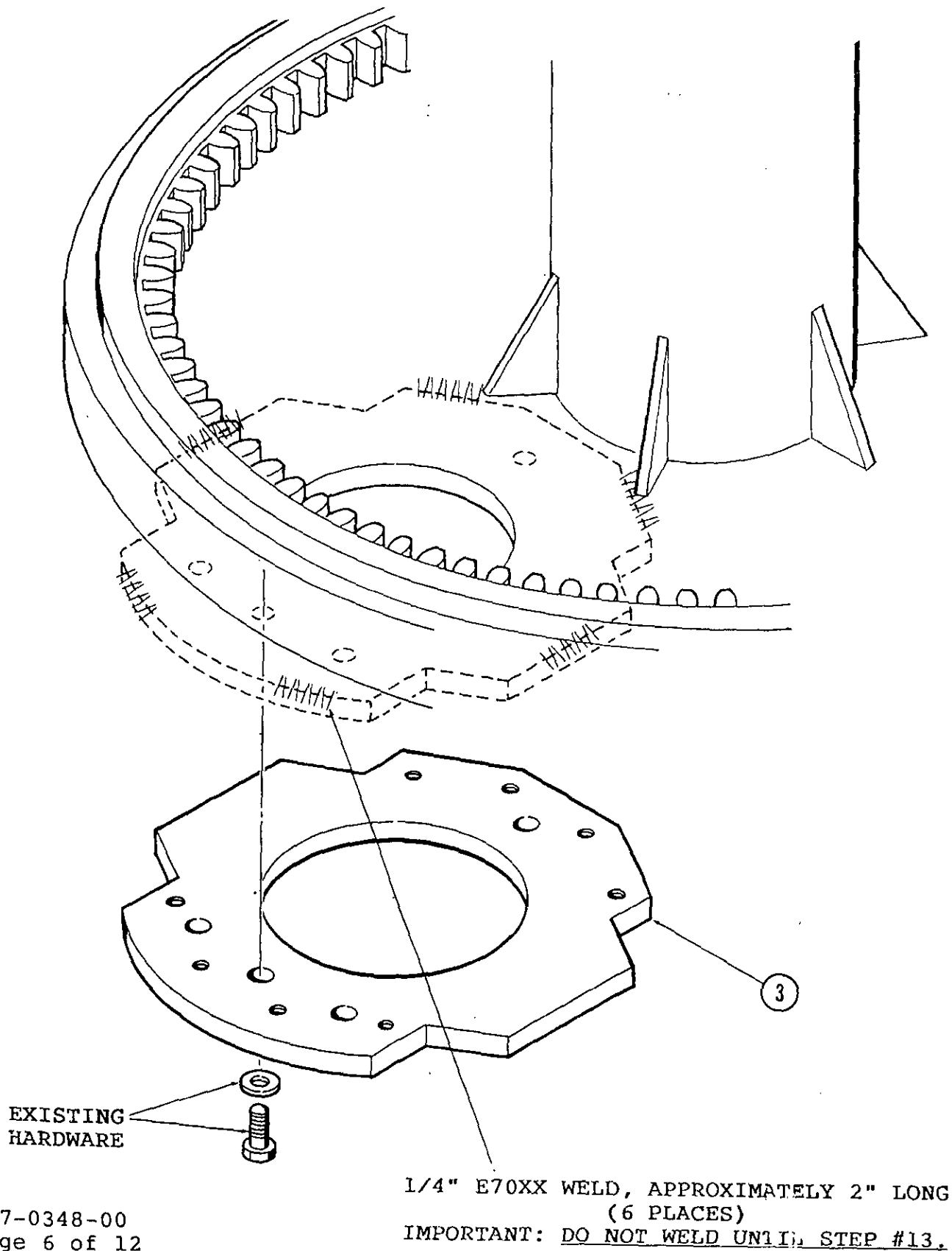

11. Install the mount assembly (Item #1 to the mount plate using the capscrews and hardened washers (Items #9 and #10). Tighten the capscrews to 105 ft-lbs. (5/8-11 Grade 5 capscrews).

IMPORTANT: Loosen the jam nuts and turn all four stop bolts out until their spherical ends do not protrude.

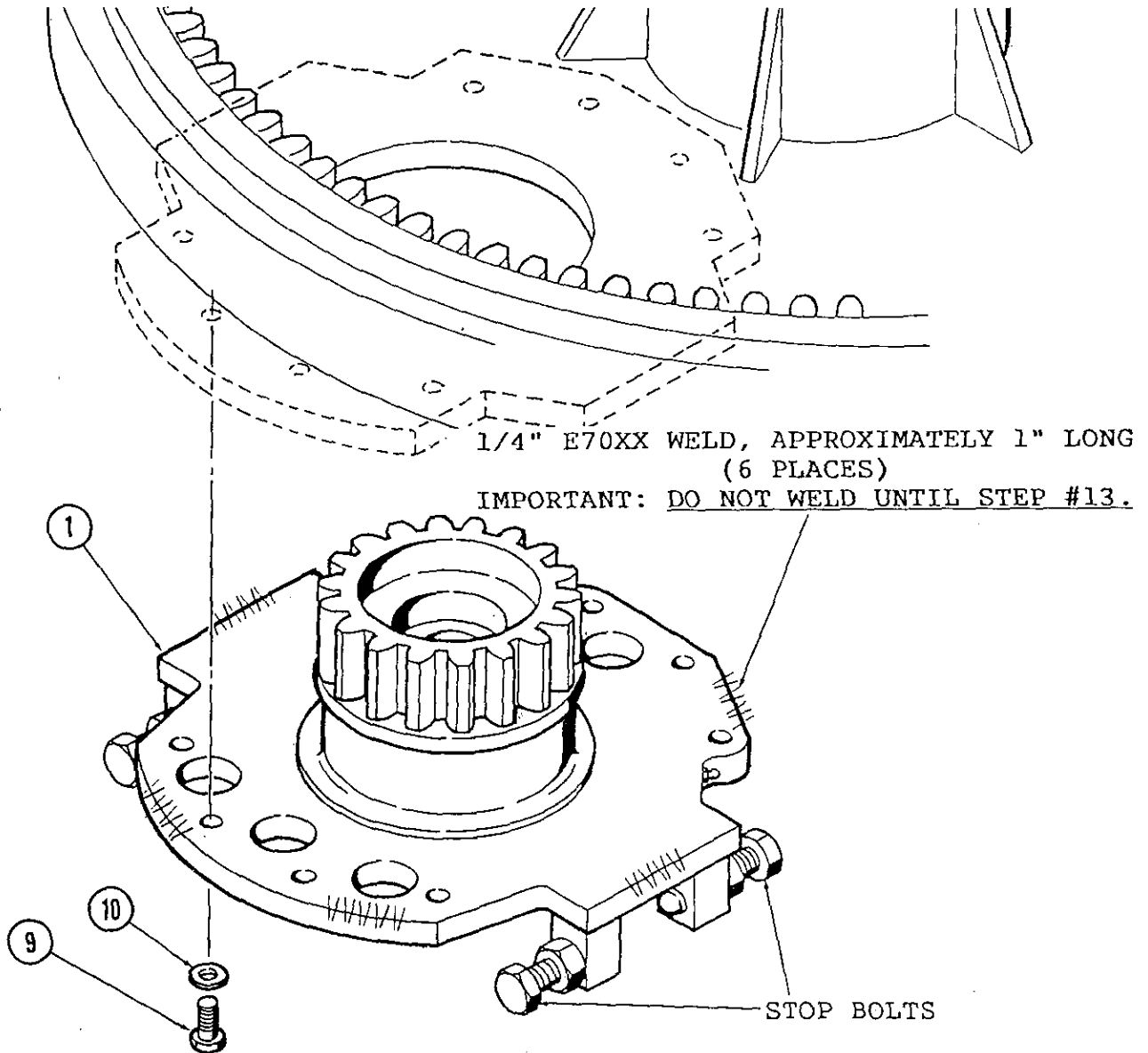

12. Adjust the mesh of the pinion gear to the ring gear by moving the mount plate as required to obtain 0.005 inch of between the teeth.
13. When the correct adjustment is obtained, tighten the four bolts to 145 ft-lbs. (5/8-11 Grade 8 bolts with hardened washer). Weld the mount plate to the frame as shown in the illustration on page 6. Weld the housing of the mount assembly to the mount plate as shown in the illustration on this page.

14. Install the motor mount (Item #2) on the motor using the existing hardware. Tighten the bolts to 185 ft-lbs. ($3/4$ -10 Grade 5 bolts with hardened washers).

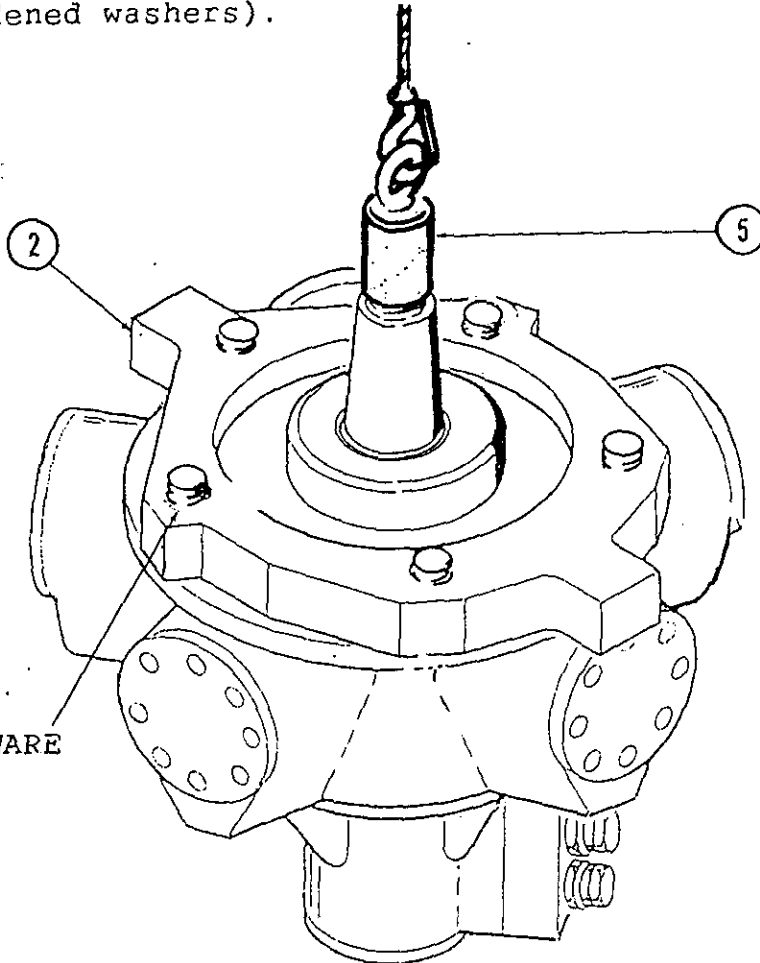

15. Install the existing key in the motor shaft keyway.
16. Install the lifting adapter (Item #5) on the hydraulic motor shaft. Attach a suitable cable or chain hoist to the lifting adapter, through the center of the pinion gear as shown on the following page.
17. Using the hoist in conjunction with the hydraulic jack, raise the motor into position. Make sure the key lines up with the keyway in the pinion.

NOTE: Do not attempt to raise the motor completely into position with the hoist. Raise it high enough that the lifting adapter can be removed and the special washer and pinion nut can be installed.

18. Make sure the motor is securely blocked from underneath and remove the lifting adapter.

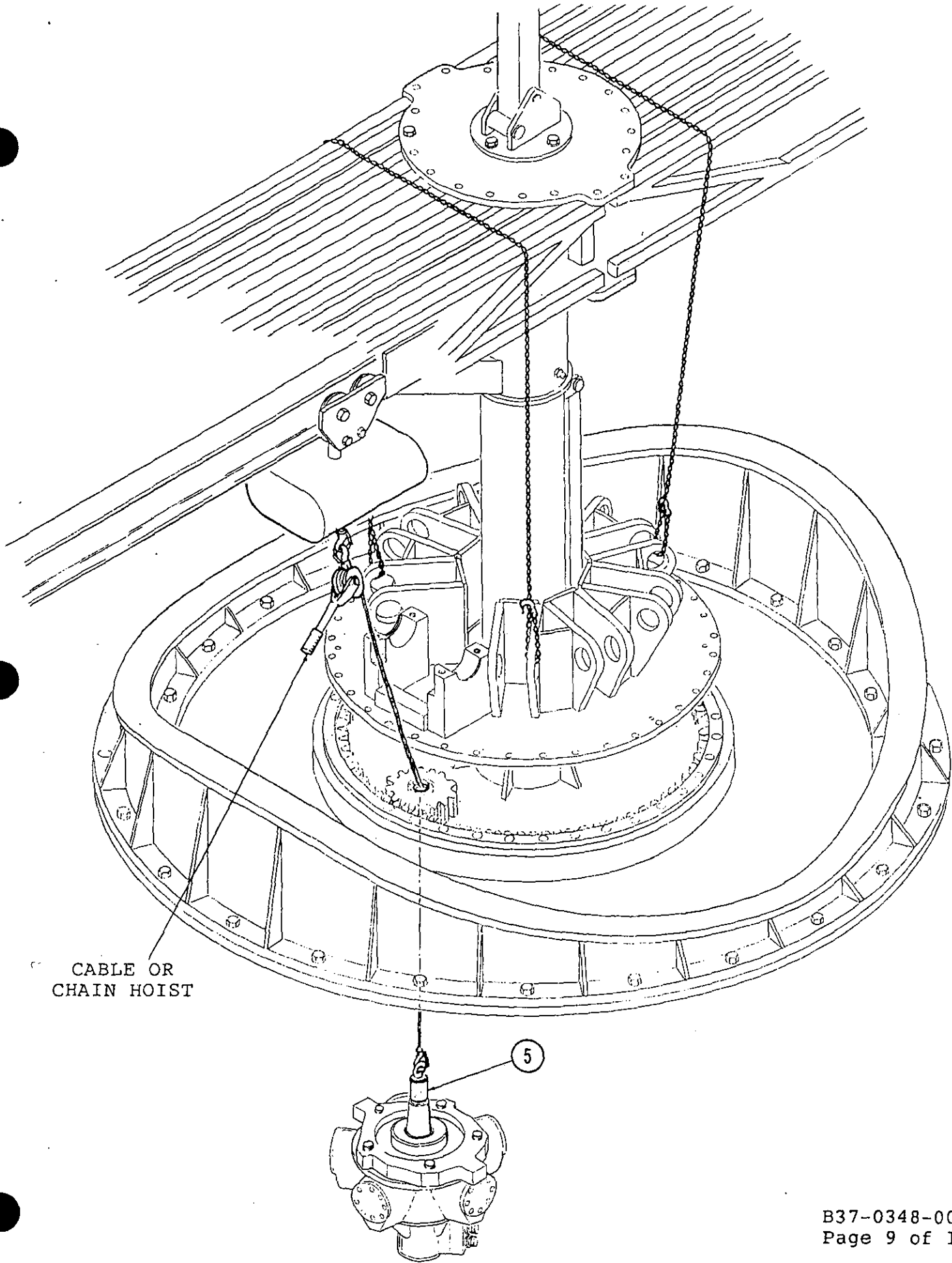

19. Install the existing special washer and new pinion nut (Item #6)

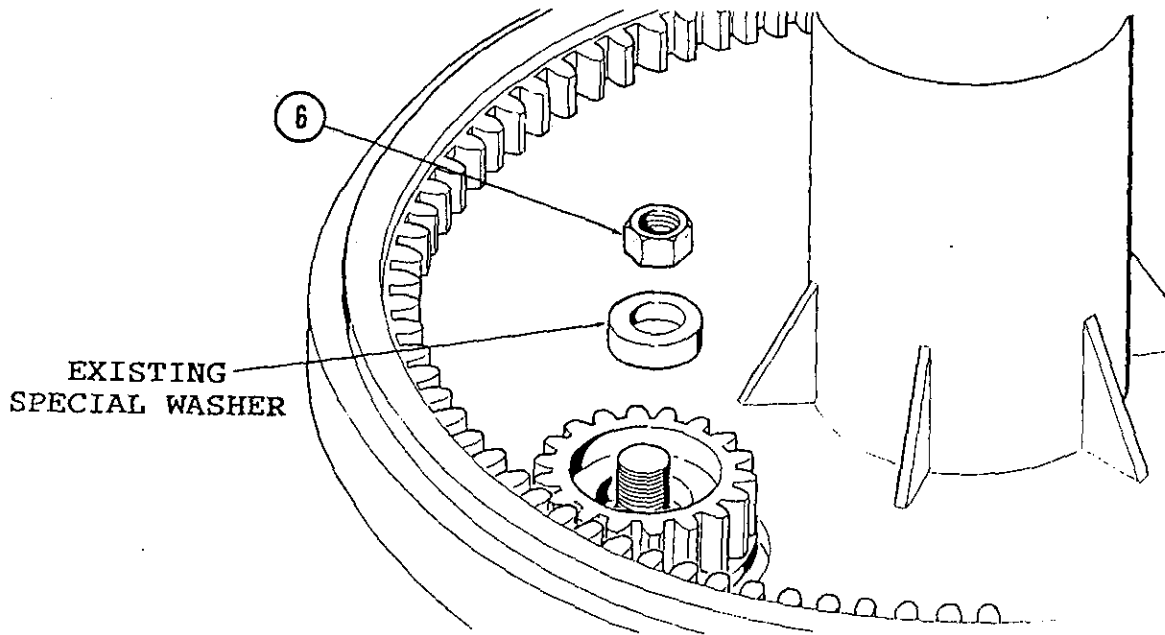

20. Tighten the nut to 700 ft-lbs. As the nut is tightened, the motor will be drawn up into position.

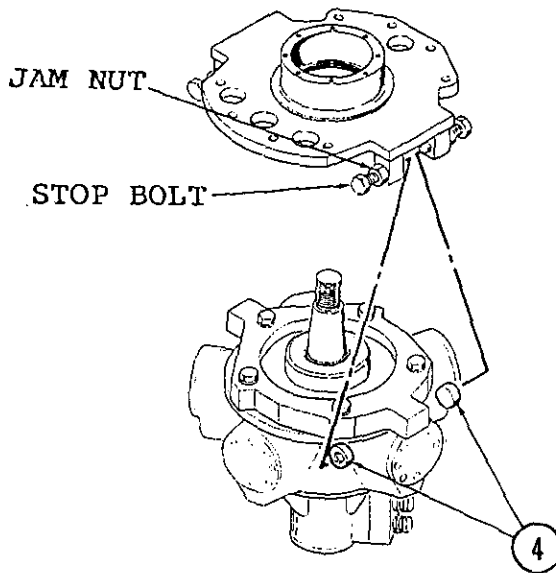

21. Tighten the four stop bolts evenly, with a pad (Item #4) installed over the spherical end of each stop bolt. Tighten the stop bolts until snug, then tighten the jam nuts.

22. Install the hydraulic hoses (Items #7 and #8).
23. Lower the center hub into position. Install the capscrews and washers and tighten to 105 ft-lbs. (5/8-11 Grade 8 capscrews with hardened washers).
24. Install all double sweeps except the master double sweep. Install the retainer shafts and tighten the capscrews to 105 ft-lbs. Install new lockwire in the capscrews.

NOTE: Install the shaft spacer on the side of the sweep spindle opposite the large end of the retainer shaft.

25. Install the master double sweep. Install the bearing caps, hardened washers and capscrews. Tighten the capscrews to 460 ft-lbs. (7/8-9 Grade 8 capscrews with hardened washers).
26. Install all sweeps on the double sweeps. Install and adjust the spreader bars as instructed in Service Bulletin B392R1004-A.
27. Complete the ride set-up procedure as described in the CHANCE OPERATION & MAINTENANCE MANUAL.

IMPORTANT: Thoroughly lubricate the bearings in the mount assembly through the grease fitting provided using No. 2 lithium base grease. The bearings must be lubricated at weekly intervals.

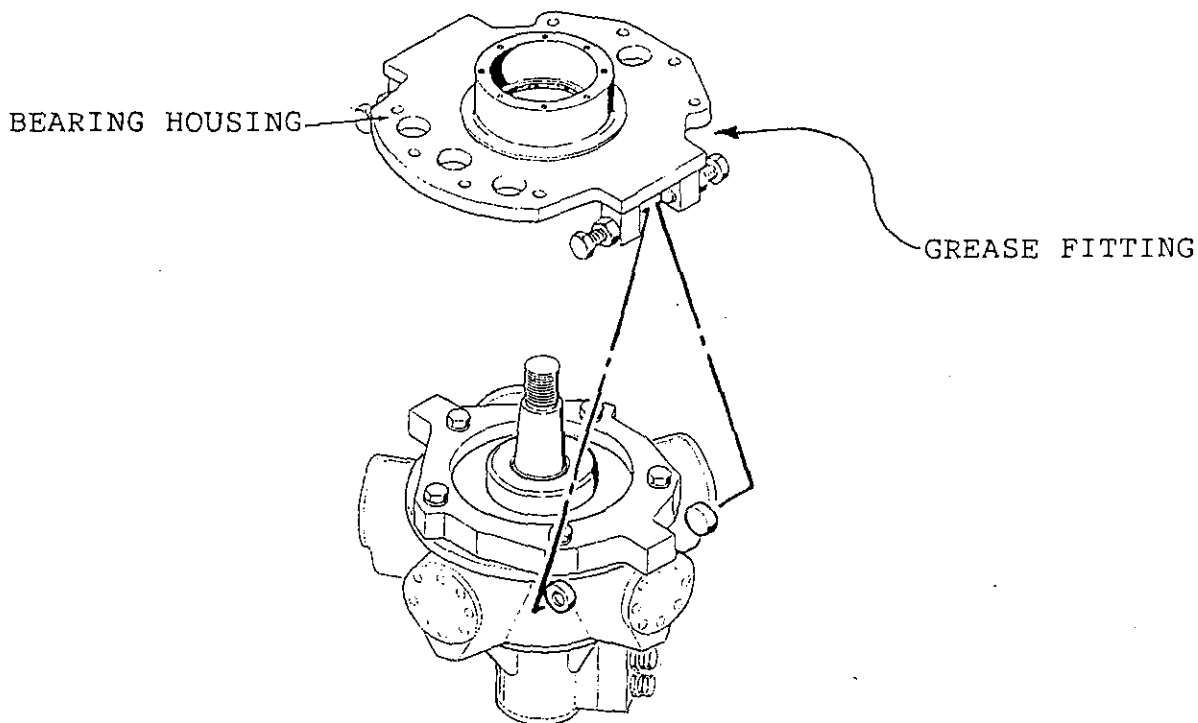

REPLACEMENT PARTS

The 34510300 MOUNT ASSEMBLY (392-618-001)
consists of the following parts

35242600	..PINION GEAR (392-624-001)	1
33493400	..BEARING HOUSING (392-609-001)	1
30742200	..STOP BOLT (392-621-004)	2
36451700	..SEAL - Upper (392-621-005)	1
36451600	..SEAL - Lower (392-621-002)	1
31220200	..BEARING CAP (392-621-001)	1
71395300	..SHIM - 0.003 (392-623-001)	A/R
71395400	..SHIM - 0.007 (392-623-002)	A/R
71395500	..SHIM - 0.015 (392-623-003)	A/R
290-0518001	..BEARING CUP	2
290-0446701	..BEARING CONE	2
290-6129801	..SNAP RING - External (4-1/4")	1
697-8981200	..GREASE FITTING - 45° (1/4-28)	1
691-4762800	..JAM NUT (7/8-9)	4
686-0786200	..CAPSCREW - Hex Head (3/8-16 x 1)	8
696-8553100	..WASHER - Hardened (3/8)	8

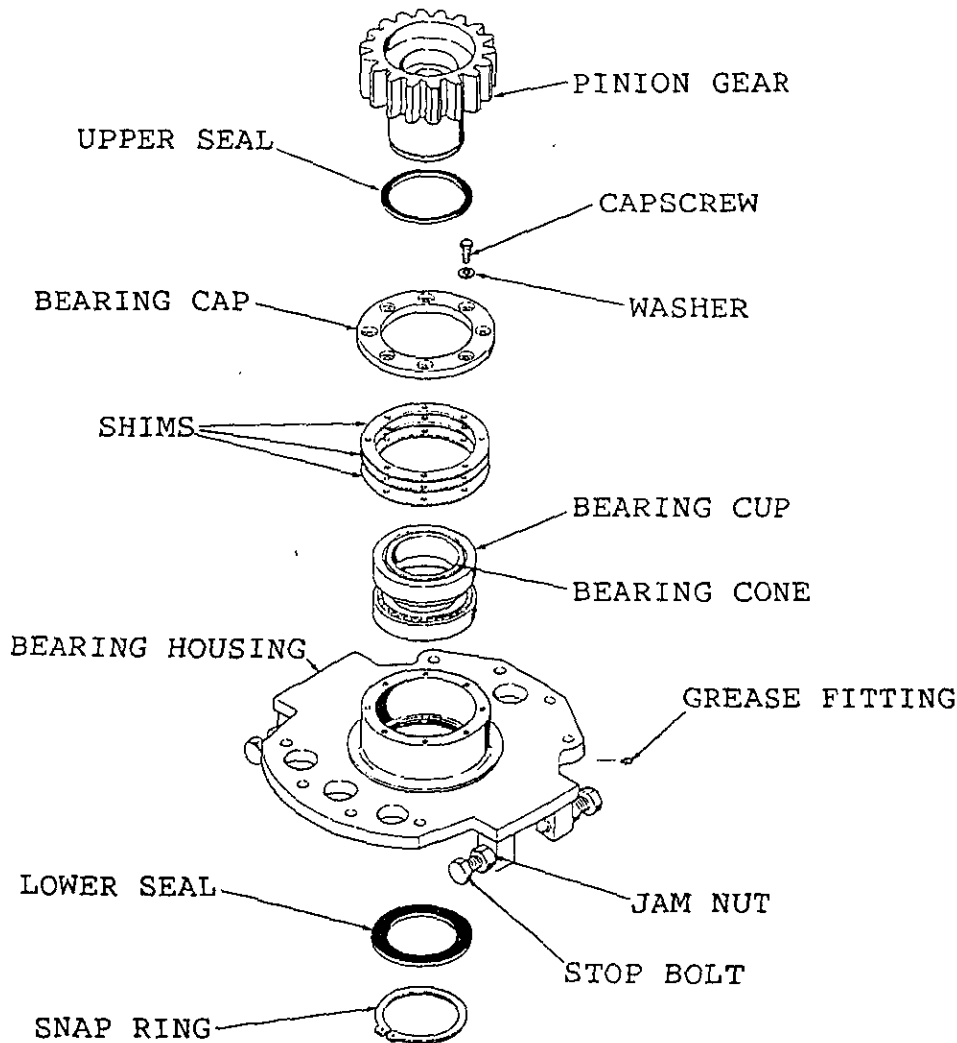



Certification of Compliance

SERVICE BULLETIN B37-0348-00

We hereby certify the procedure outlined in the above-mentioned service bulletin has been performed on the _____

Serial No(s) _____, in accordance with the instructions and specifications supplied by Chance Manufacturing Company, Inc.

Date Bulletin Received _____

Date Procedure Performed _____

Name and Address of Person performing Procedure:

Attested:

Owner _____

Maintenance Supervisor _____

Address _____

Address _____

City _____ State _____

City _____ State _____

By: _____

Date: _____

Date: _____

Results: _____

This certification must be completed and returned to Chance Manufacturing Company, Inc. within fifteen (15) days of receipt of the bulletin



Number: B37-0348-0A

Date: July 28, 1989

Supersedes: B37-0348-00

America's Largest Manufacturer of Amusement Rides

SERVICE BULLETIN

Effective Serial Numbers: 86-2766 and 85-53001 through 85-5307

Ride: THUNDERBOLT / MUSIC FEST

Subject: Hydraulic Motor Mount Rework



WARNING: FAILURE TO COMPLY WITH THIS SERVICE BULLETIN CAN RESULT IN FAILURE OF THE DRIVE MOTOR, CAUSING THE RIDE TO STOP ABRUPTLY. THIS CAN RESULT IN INJURY TO PASSENGERS.

This bulletin supersedes Service Bulletin No. B37-0348-00. It is no longer in effect and should be destroyed.

It has been determined by CHANCE MANUFACTURING CO., INC. that the hydraulic drive motor shaft can fail during operation. The motor mount and pinion gear have been redesigned to reduce the load on the motor shaft.

All owners of the above noted THUNDERBOLT and MUSIC FEST amusement rides are required to perform the rework described in this bulletin by January 1, 1990.

Perform the rework using the instructions on the following pages of this bulletin. Order Kit No. K392R1042-0 and install the kit using the instructions provided. All work must be performed by qualified personnel, capable of understanding the function of the parts and their proper installation.

Return the attached Certification Of Compliance no later than January 1, 1990. If there are any questions regarding the instructions or this inspection, contact the CHANCE CUSTOMER SERVICE DEPARTMENT.

Factory and Sales Office: 4219 Irving • P.O. Box 12328 • Wichita, Kansas 67277 • (316) 942-7411

PARTS LIST - Kit No. K392R1042-0,
The following parts are included to rework one ride.

Ref. No.	Part Number	Description	Qty. Reqd.
1.	34510300	*MOUNT ASSEMBLY (392-618-001)	1
2.	34517006	MOTOR MOUNT (392-615-001)	1
3.	34517007	MOUNT PLATE (392-616-001)	1
4.	34946300	PAD (392-621-003)	4
5.	--	LIFTING ADAPTER	1
6.	64806900	NUT - Pinion (1-1/2 - 12 Flexlock)	1
7.	33476502	HOSE - Hydraulic (392-650-001)	1
8.	33476503	HOSE - Hydraulic (392-650-002)	2
9.	60910600	CAPSCREW - Grade 5 (5/8-11 x 1-3/4)	8
10.	68552900	WASHER - Hardened (5/8)	8

* For replacement parts for the motor mount assembly, refer to drawing on page 12 of this bulletin.



WARNING: The hydraulic motor and its mounting components are extremely heavy. To prevent personal injury, never attempt to remove or install any parts without a jack and blocking to adequately support the parts as they are lowered or raised.

REWORK INSTRUCTIONS

NOTE: This rework requires partial disassembly of the ride. Use the normal tear-down or set up procedures given in the CHANCE OPERATION & MAINTENANCE MANUAL when a partially disassembled ride configuration is required.

1. Remove all cars and spreader bars from the ride. Use the chain hoist to remove all sweeps from the double sweeps.
2. Use the chain hoist to support the master double sweep and remove the bearing caps. Move the double sweep out of the way.

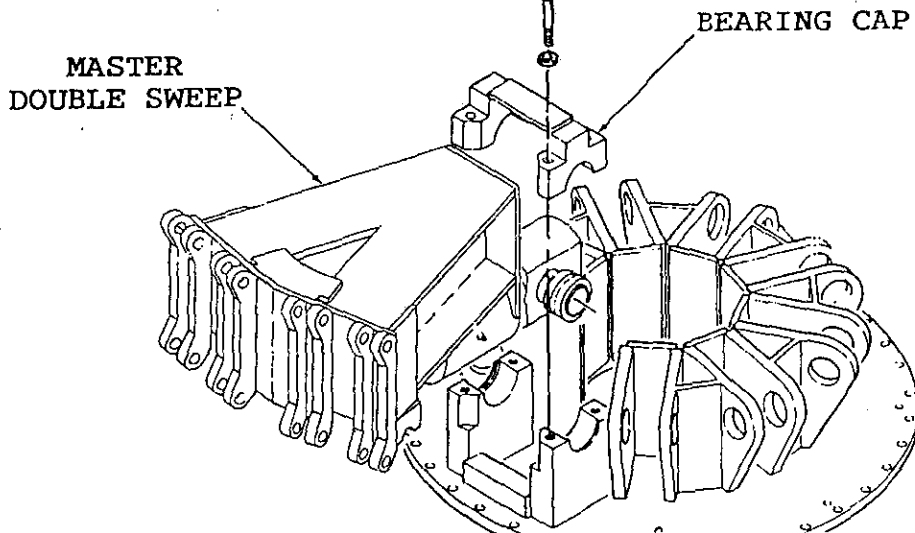

3. Use the chain hoist to remove the remaining double sweeps. Remove the sweep spindle retainer shafts and move the double sweeps out of the way.

IMPORTANT: Keep each retainer shaft with the sweep spindle from which it is removed. The double sweeps should be marked so that they are installed in their original positions.

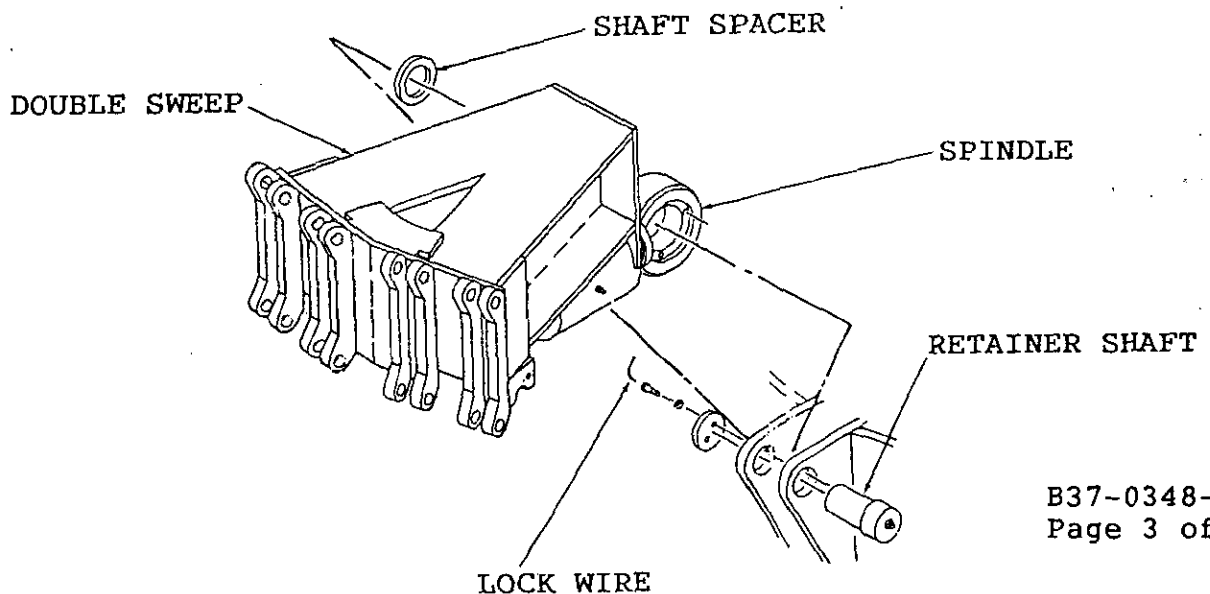

4. Remove the capscrews from the center hub.
5. With the center truss pole retracted, install chains across the trusses and attach to the center hub in four places as shown. Carefully raise the center pole, lifting the center hub. Install the safety bar.

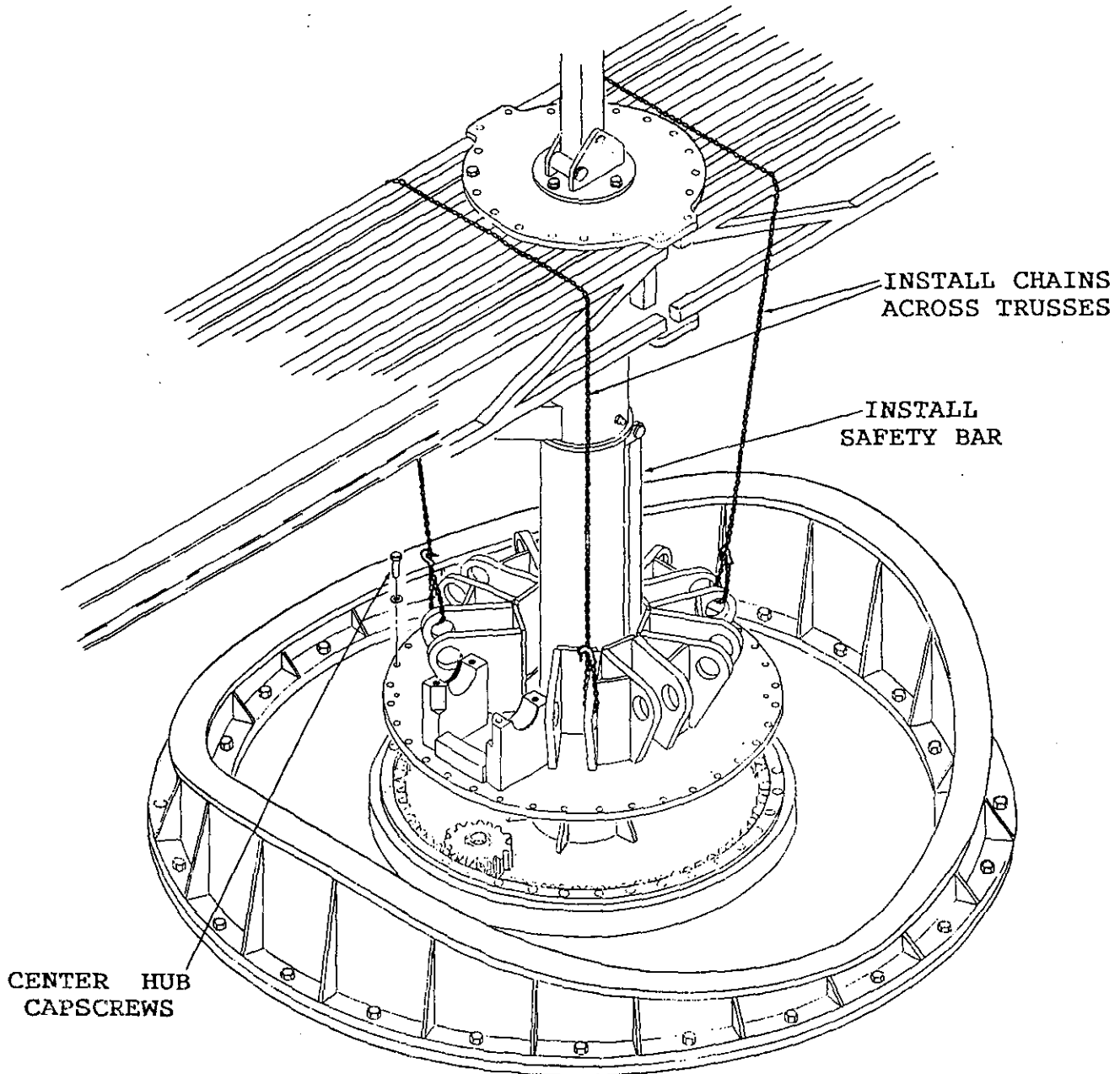

6. Remove the plumbing from the hydraulic motor. Make note of which ports are connected by each hydraulic line. These lines will be replaced with new hoses.

7. Using a hydraulic jack and blocking under the hydraulic motor, remove the five capscrews which mount the motor. Lower and remove the motor.
8. Remove the pinion nut and special washer from the motor shaft. Use a suitable puller to remove the pinion gear from the motor shaft. Return the pinion gear to the factory. Discard the nut, but save the special washer and the key.
9. Use an air/arc to remove the weld between the existing motor mount and the hub. Remove the attaching hardware and remove the motor mount. Grind the surface to remove any remaining weld.

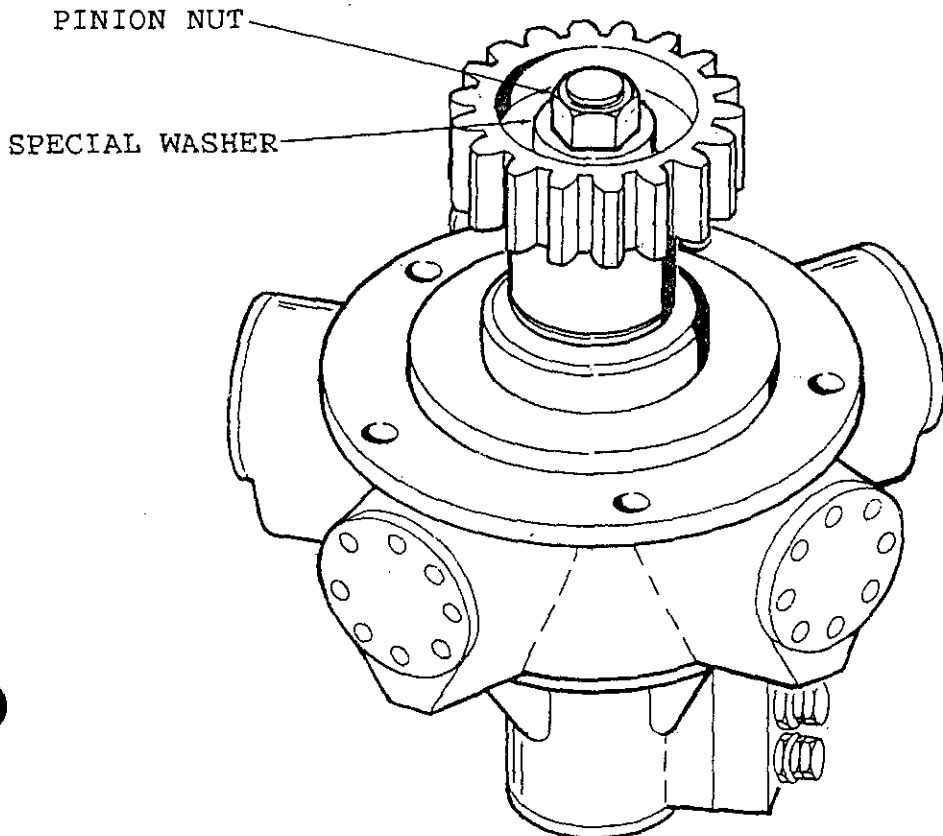
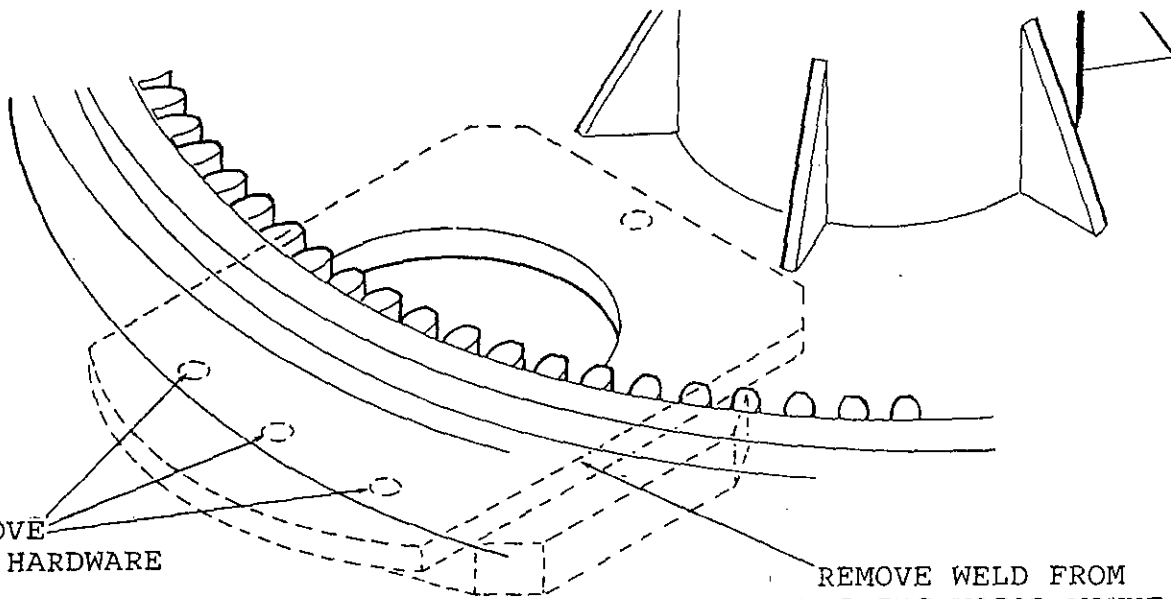

10. Install the new mount plate (Item #3) with the existing hardware, but do not tighten at this time.

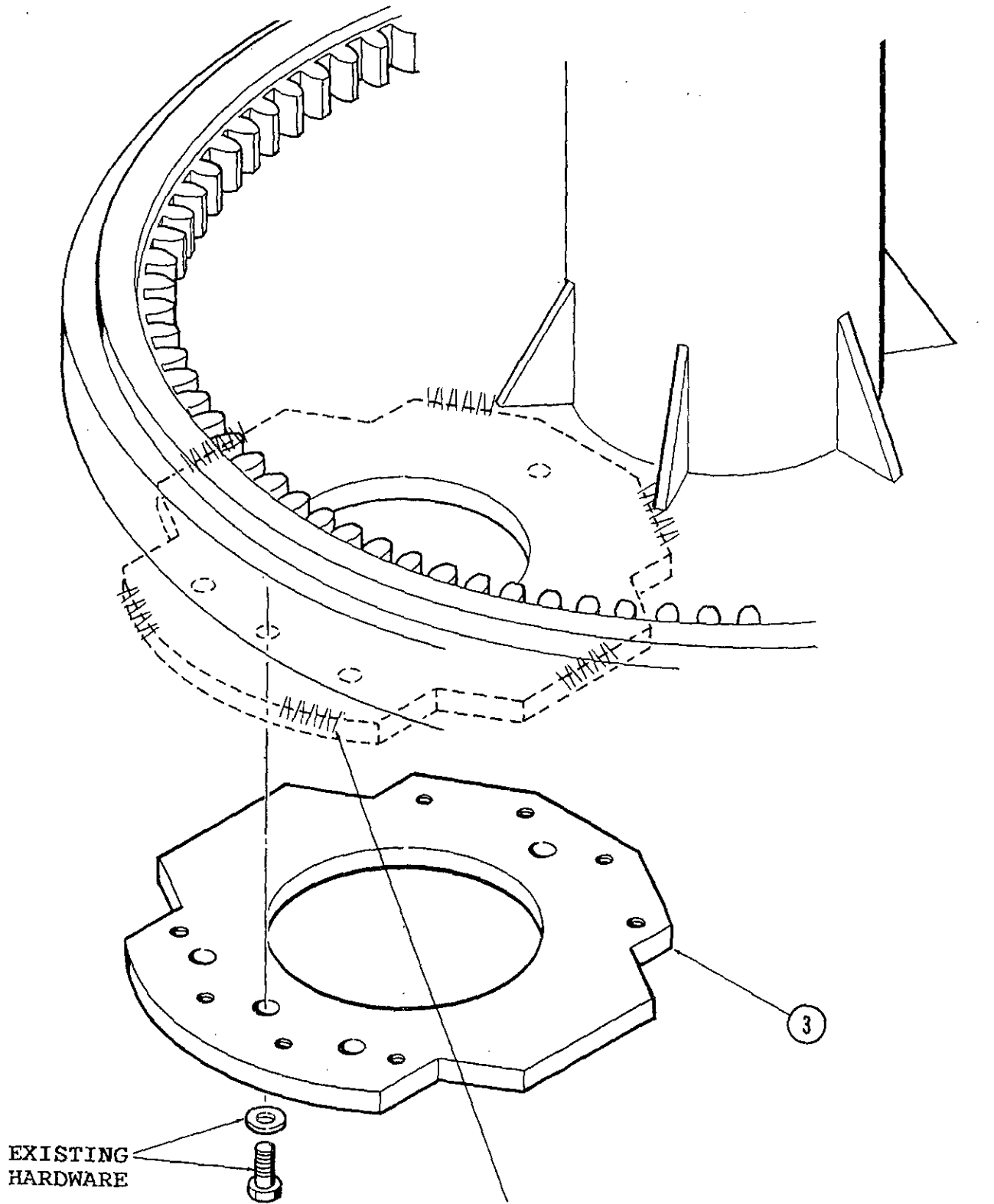

1/4" E70XX WELD, APPROXIMATELY 2" LONG
(6 PLACES)
IMPORTANT: DO NOT WELD UNTIL STEP #13.

11. Install the mount assembly (Item #1 to the mount plate using the capscrews and hardened washers (Items #9 and #10). Tighten the capscrews to 105 ft-lbs. (5/8-11 Grade 5 capscrews).

IMPORTANT: Loosen the jam nuts and turn all four stop bolts out until their spherical ends do not protrude.

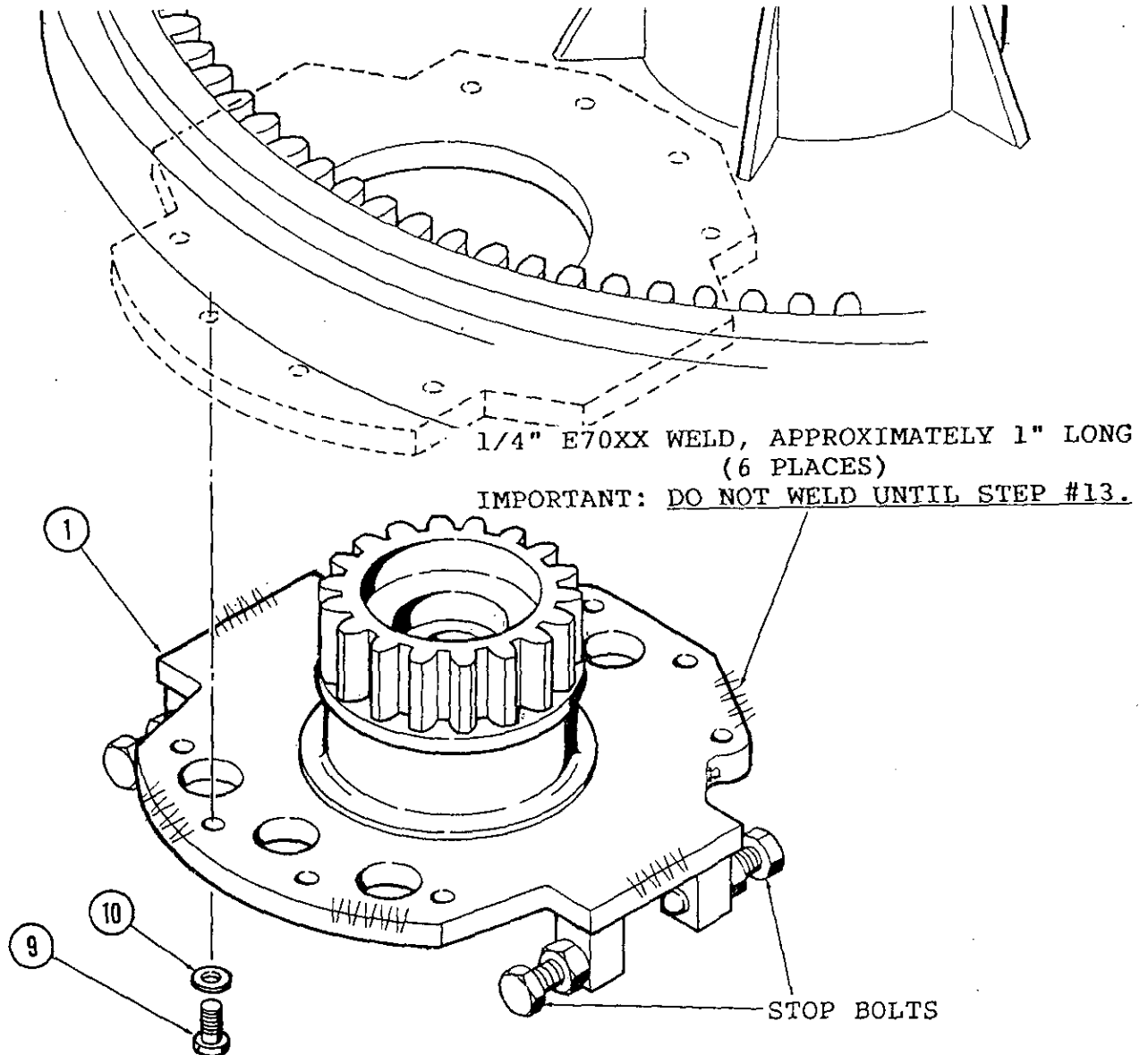

12. Adjust the mesh of the pinion gear to the ring gear by moving the mount plate as required to obtain 0.005 inch of between the teeth.
13. When the correct adjustment is obtained, tighten the four bolts to 145 ft-lbs. (5/8-11 Grade 8 bolts with hardened washer). Weld the mount plate to the frame as shown in the illustration on page 6. Weld the housing of the mount assembly to the mount plate as shown in the illustration on this page.

14. Install the motor mount (Item #2) on the motor using the existing hardware. Tighten the bolts to 185 ft-lbs. ($3/4$ -10 Grade 5 bolts with hardened washers).

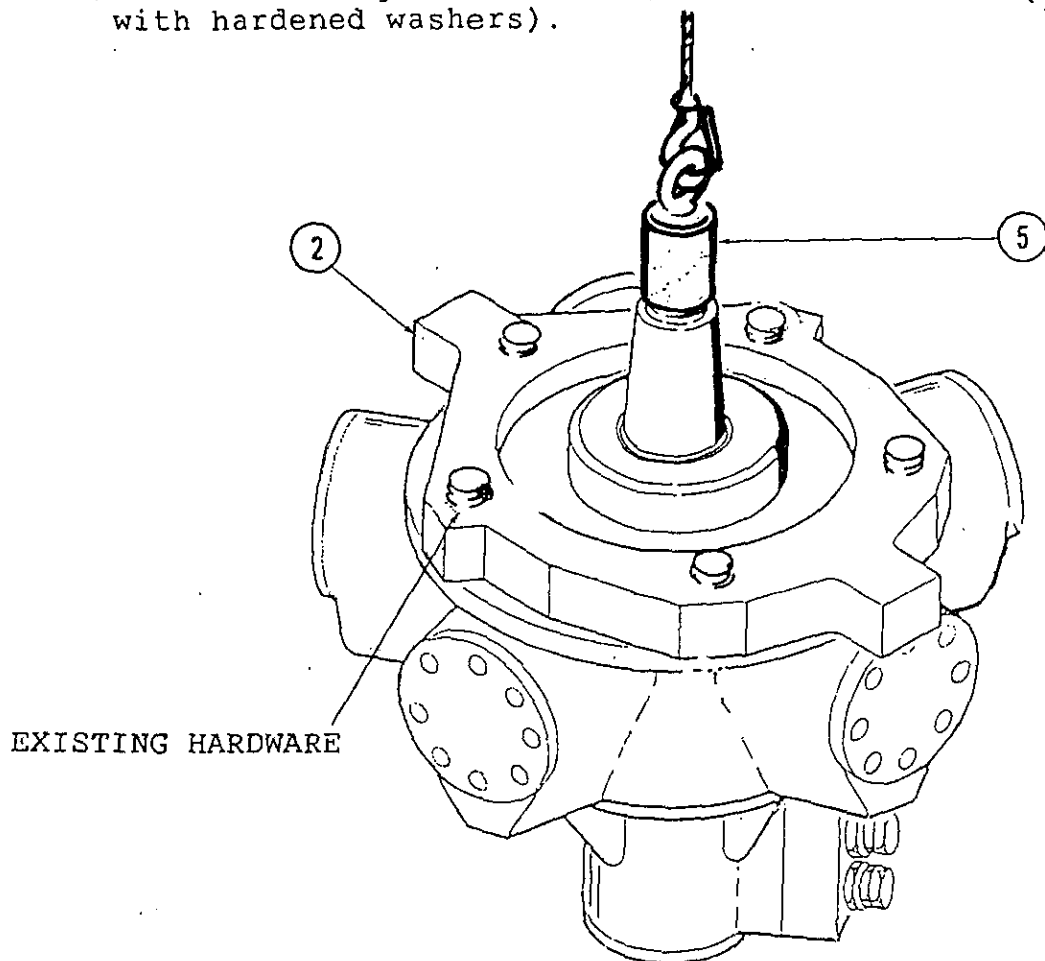

15. Install the existing key in the motor shaft keyway.
16. Install the lifting adapter (Item #5) on the hydraulic motor shaft. Attach a suitable cable or chain hoist to the lifting adapter, through the center of the pinion gear as shown on the following page.
17. Using the hoist in conjunction with the hydraulic jack, raise the motor into position. Make sure the key lines up with the keyway in the pinion.

NOTE: Do not attempt to raise the motor completely into position with the hoist. Raise it high enough that the lifting adapter can be removed and the special washer and pinion nut can be installed.

18. Make sure the motor is securely blocked from underneath and remove the lifting adapter.

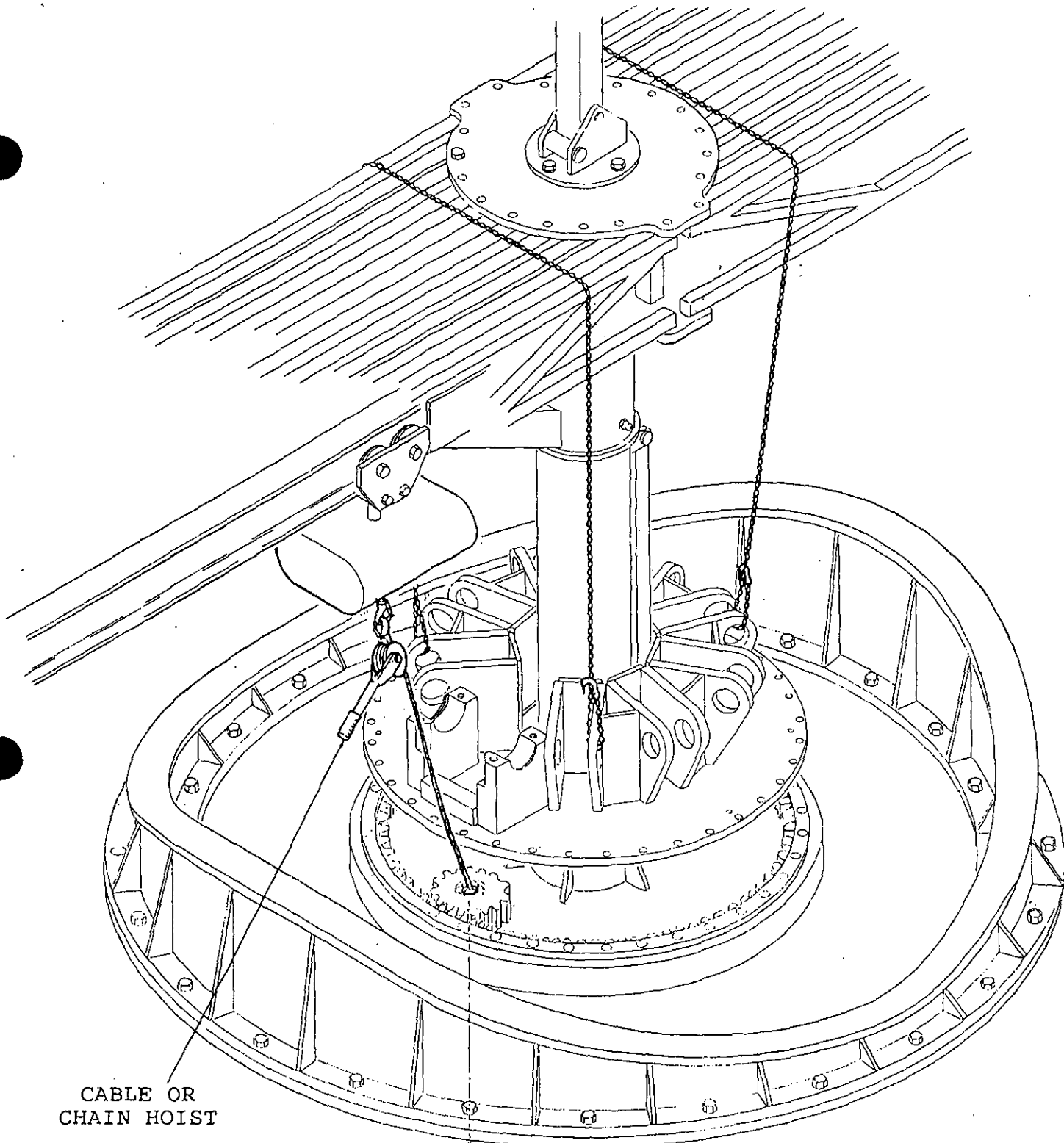

CABLE OR
CHAIN HOIST

5

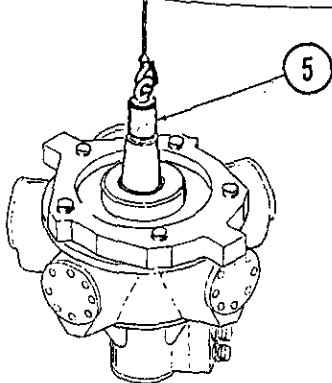

19. Install the existing special washer and new pinion nut (Item #6)

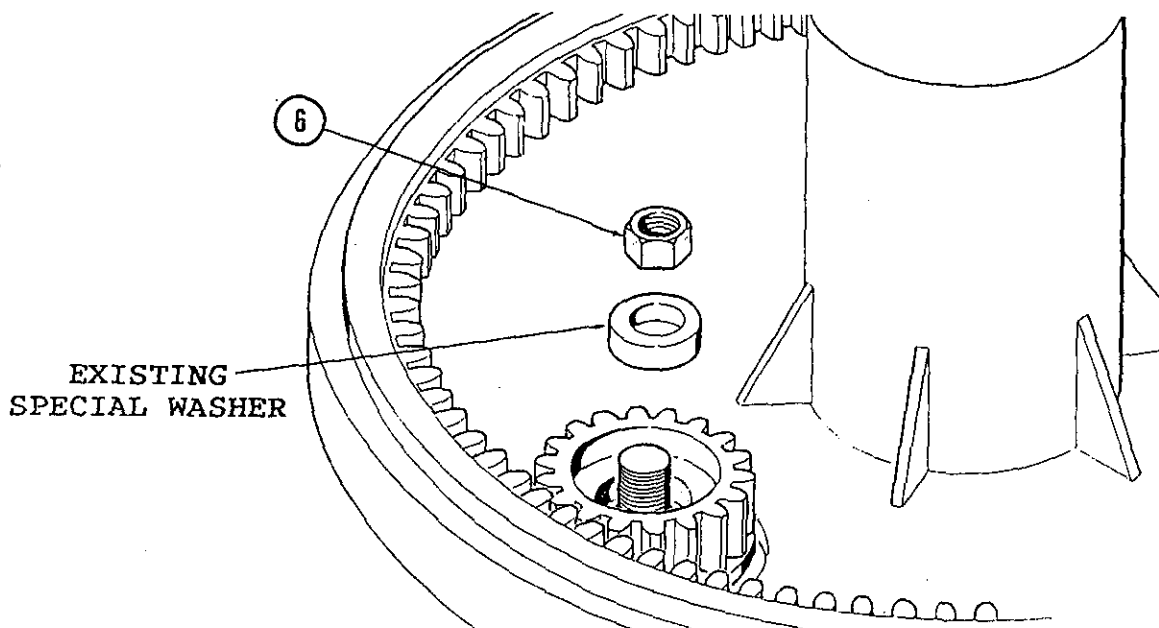

20. Tighten the nut to 700 ft-lbs. As the nut is tightened, the motor will be drawn up into position.

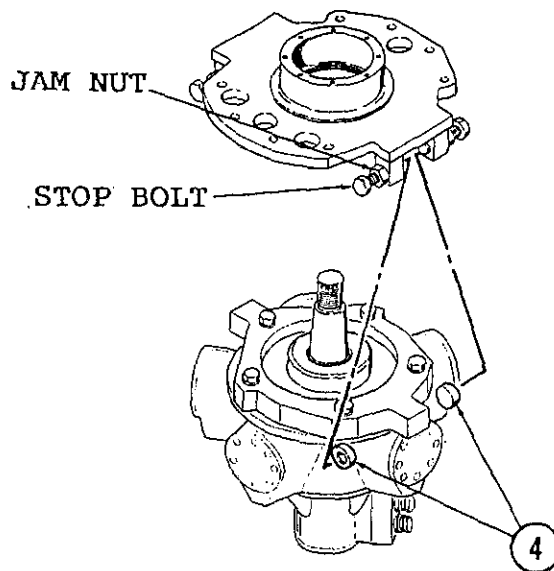

21. Tighten the four stop bolts evenly, with a pad (Item #4) installed over the spherical end of each stop bolt. Tighten the stop bolts until snug, then tighten the jam nuts.

22. Install the hydraulic hoses (Items #7 and #8).
23. Lower the center hub into position. Install the capscrews and washers and tighten to 105 ft-lbs. (5/8-11 Grade 8 capscrews with hardened washers).
24. Install all double sweeps except the master double sweep. Install the retainer shafts and tighten the capscrews to 105 ft-lbs. Install new lockwire in the capscrews.

NOTE: Install the shaft spacer on the side of the sweep spindle opposite the large end of the retainer shaft.

25. Install the master double sweep. Install the bearing caps, hardened washers and capscrews. Tighten the capscrews to 460 ft-lbs. (7/8-9 Grade 8 capscrews with hardened washers).
26. Install all sweeps on the double sweeps. Install and adjust the spreader bars as instructed in Service Bulletin B392R1004-A.
27. Complete the ride set-up procedure as described in the CHANCE OPERATION & MAINTENANCE MANUAL.

IMPORTANT: Thoroughly lubricate the bearings in the mount assembly through the grease fitting provided using No. 2 lithium base grease. The bearings must be lubricated at weekly intervals.

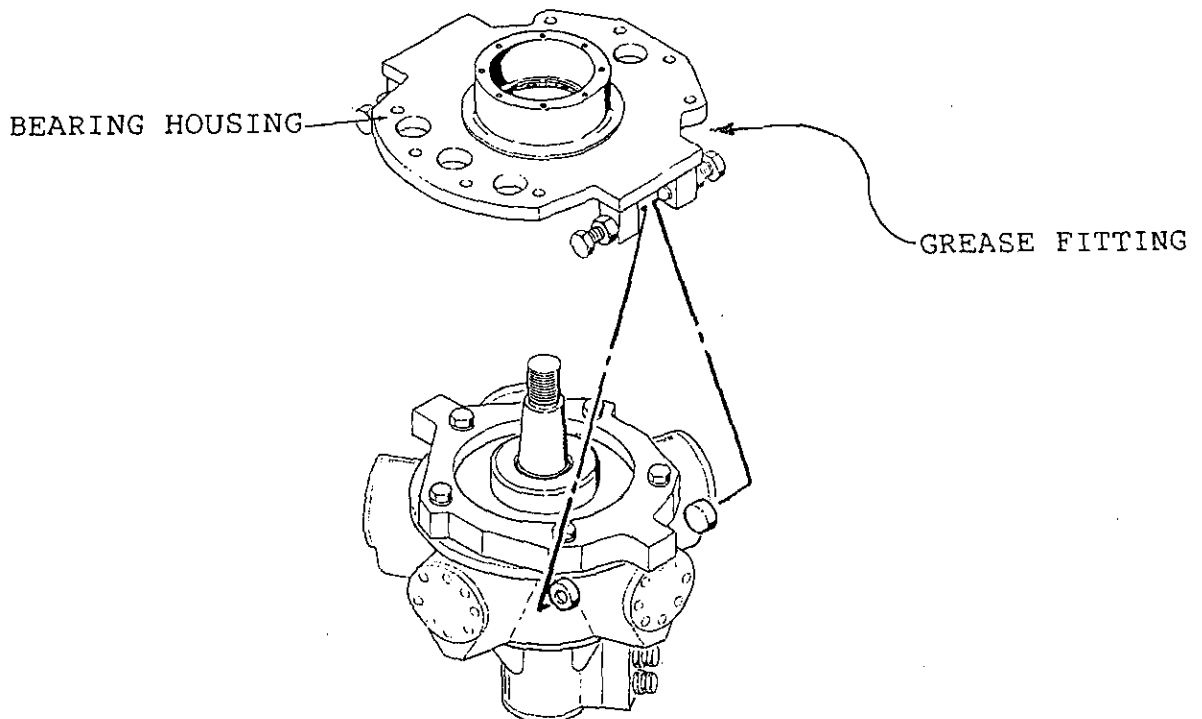

REPLACEMENT PARTS

The 34510300 MOUNT ASSEMBLY (392-618-001)
consists of the following parts

35242600	..PINION GEAR (392-624-001)	1
33493400	..BEARING HOUSING (392-609-001)	1
30742200	..STOP BOLT (392-621-004)	2
36451700	..SEAL - Upper (392-621-005)	1
36451600	..SEAL - Lower (392-621-002)	1
31220200	..BEARING CAP (392-621-001)	1
71395300	..SHIM - 0.003 (392-623-001)	A/R
71395400	..SHIM - 0.007 (392-623-002)	A/R
71395500	..SHIM - 0.015 (392-623-003)	A/R
290-0518001	..BEARING CUP	2
290-0446701	..BEARING CONE	2
290-6129801	..SNAP RING - External (4-1/4")	1
697-8981200	..GREASE FITTING - 45° (1/4-28)	1
691-4762800	..JAM NUT (7/8-9)	4
686-0786200	..CAPSCREW - Hex Head (3/8-16 x 1)	8
696-8553100	..WASHER - Hardened (3/8)	8

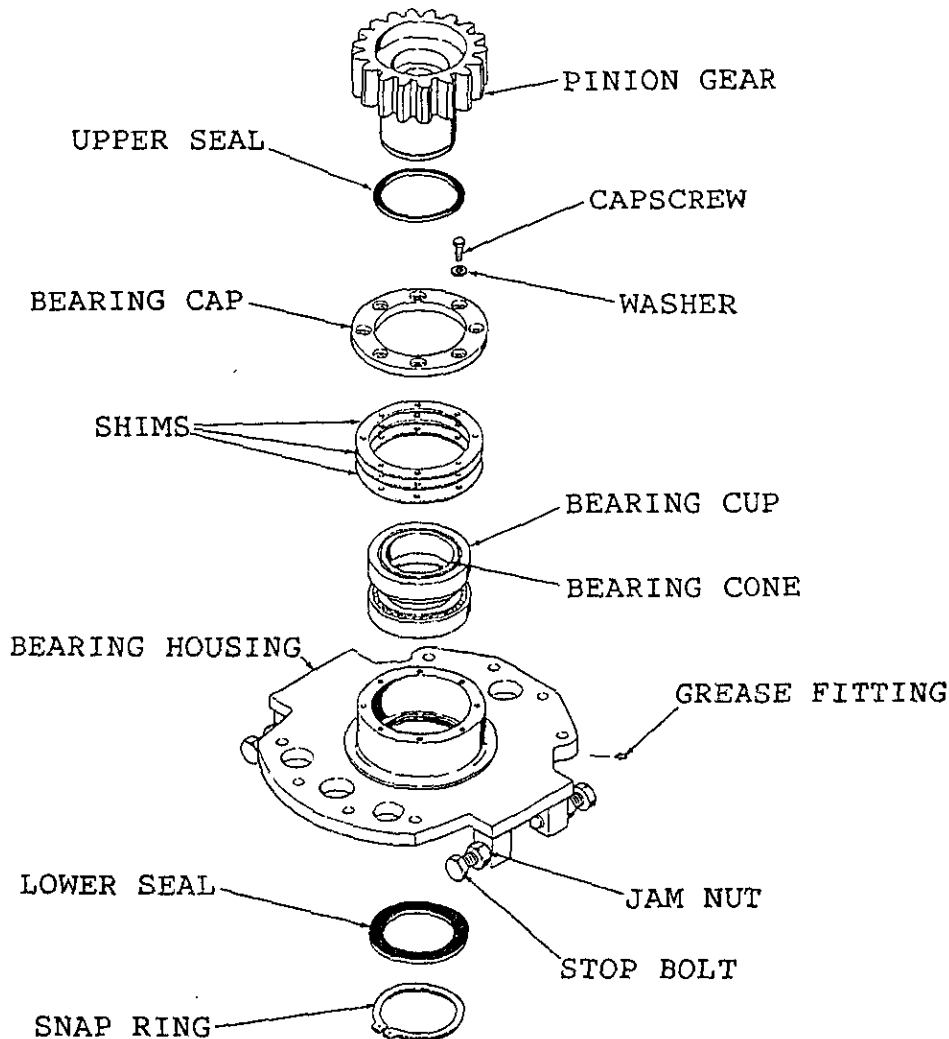



Certification of Compliance

SERVICE BULLETIN B37-0348-00

We hereby certify the procedure outlined in the above-mentioned service bulletin has been performed on the _____

Serial No(s) _____, in accordance with the instructions and specifications supplied by Chance Manufacturing Company, Inc.

Date Bulletin Received _____

Date Procedure Performed _____

Name and Address of Person performing Procedure:

Attested:

Owner _____

Maintenance Supervisor _____

Address _____

Address _____

City _____ State _____

City _____ State _____

By: _____

Date: _____

Date: _____

Results: _____

This certification must be completed and returned to Chance Manufacturing Company, Inc. no later than January 1, 1990.