



NUMBER: B402R1102-0

DATE: JUNE 14, 1991

SUPERSEDES:

---

---

## SERVICE BULLETIN

---

---

Effective Serial Number: All Units - Chance Rides, Inc.

Ride: WIPEOUT

Subject: Boom Limit Switch

Chance Rides, Inc. has received reports of at least one WIPEOUT amusement ride which was operated with the boom limit switch being by-passed. This could allow the lap bars to be unlocked during operation of the ride, resulting in possible injury to passengers.

**NEVER OPERATE THE RIDE WITH THE BOOM LIMIT SWITCH BY-PASSED OR TIED DOWN.**

The boom limit switch is a safety item located on the boom support stand of the turret. This switch locks out the lap bar switch, located on seat number 1, so that the lap bars cannot be unlocked while the ride is up in the air.

All maintenance personnel and operators must be instructed as to the importance of this switch. This switch must be properly adjusted at all times during operation.

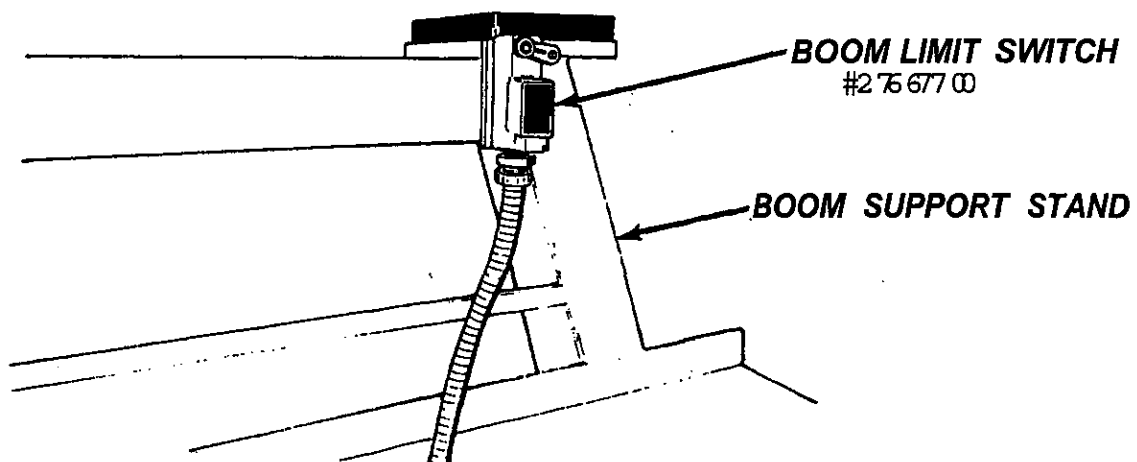



NUMBER: B402R1104-0

DATE: OCT. 11, 1991

SUPERSEDES:

---

---

## SERVICE BULLETIN

---

---

Effective Serial Number: 40200190 through 40201791

Ride: WIPEOUT

Subject: Ball Stud Recall

Chance Rides, Inc. has become aware that some parts not adequate for their intended use were received and possibly used on some WIPEOUT amusement rides. These parts are the ball studs holding the gas springs in place on the lap bars. If a ball stud breaks the lap bar can fall to the closed position, causing possible injury to passengers.

All owner/operators of WIPEOUT rides identified above are required to comply with this service bulletin.

Install the 40 ball studs, 2 per lap bar, part number 27536300 as shown in this bulletin. To receive credit for ball studs shipped with this bulletin return the completed Certification Of Compliance and the old ball studs within fifteen (15) days from receipt of bulletin.

All work must be performed by qualified personnel, capable of understanding the function of the parts and their proper installation.

### NOTICE

use only those components authorized, specified or provided by Chance Rides, Inc.

Chance Rides, Inc. SPECIFICALLY DISCLAIMS ANY LIABILITY for losses associated with any unauthorized alterations and/or modifications or additions and installations of unauthorized components.

Ball Stud Replacement Procedures:

1. Access lap bar locking mechanism by removing countertop panel.
2. Remove retainer clip from each end of gas spring.
3. Remove the gas spring from the ball studs.
4. Unscrew one ball stud from the lap bar gear assembly and one from the lap bar mount assembly.
5. Using the new ball studs, reverse the above procedure.

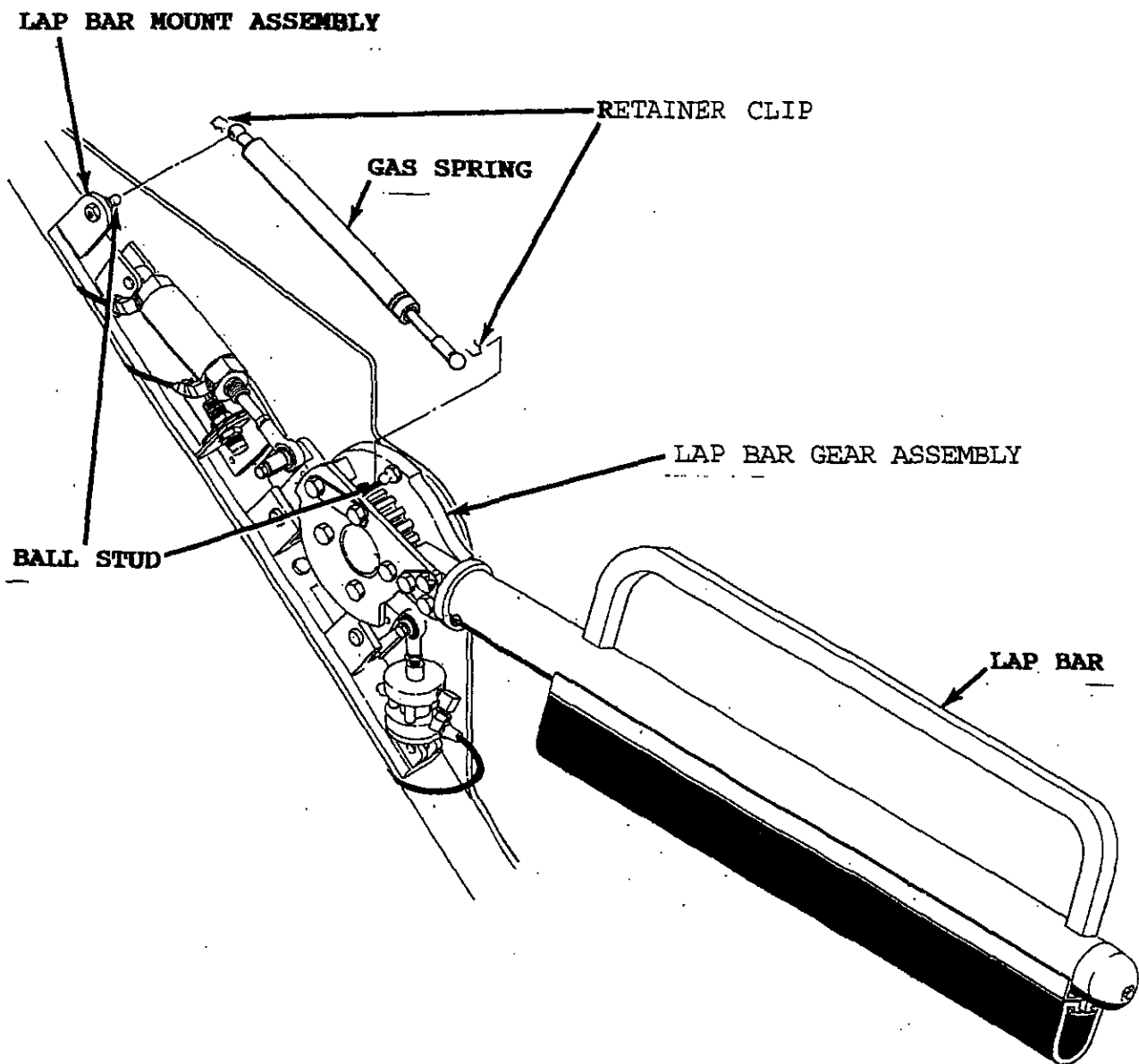



NUMBER: B402R1107-0

DATE: NOV. 22, 1991

SUPERSEDES:

---

---

## SERVICE BULLETIN

---

---

Effective Serial Number: 40200190 through 40201691

Ride: WIPEOUT

Subject: Air Filter Kit Rework

Chance Rides, Inc. has become aware that foreign material in the air system may become entrapped in the directional control valves of the brake system on the WIPEOUT amusement ride. If this occurs, damage to the valves may result, making the replacement of the valves necessary. Chance Rides, Inc. has developed a filter kit to help reduce the possibility of this damage occurring.

All owner/operators of the above noted WIPEOUT rides are required to order and install Kit #K402R1107-0. Perform the rework using the instructions provided with this bulletin. Return the attached Certification Of Compliance within fifteen (15) days from receipt of kit.

### PARTS LIST

The following parts are included in Kit #K402R1107-0 and are available at no charge if ordered within 90 days from the date of this bulletin.

<u>Part</u>	<u>Number</u>	<u>Description</u>	<u>Qty Required</u>
1	62765800	1/4 Close Nipple	1
2	22668400	Filter	1
3	33476573	Hose	
4	60018800	1/4 to 1/2 Adapter	

All work must be performed by qualified personnel, capable of understanding the function of the parts and their proper installation.

### NOTICE

Use only those components authorized, specified or provided by Chance Rides, Inc.

Chance Rides, Inc. SPECIFICALLY DISCLAIMS ANY LIABILITY for losses associated with any unauthorized alterations and/or modifications or additions and installations of unauthorized components.

## KIT INSTALLATION INSTRUCTIONS

1. Locate and remove the 1/2" hard line that connects the air tanks to the directional control valves, as shown in illustration A.
2. Remove the 1/2" to 1/4" adapter from the 1/4" tee, as shown in Illustration A.

NOTE: Use a thread sealant before installing new components.

3. Install 1/4" close nipple (Item 1) to the 1/4" tee, as shown in Illustration B.
4. Install air filter (Item 2) into close nipple (Item 1) with thread connection pointing upwards.
5. Install 1/4" to 1/2" adapter (Item 4) into end of filter (Item 2).
6. Connect adapter (Item 4) to the air tanks with air hose (Item 3).

NOTE: Check and clean or replace air filter at least once each operating season.

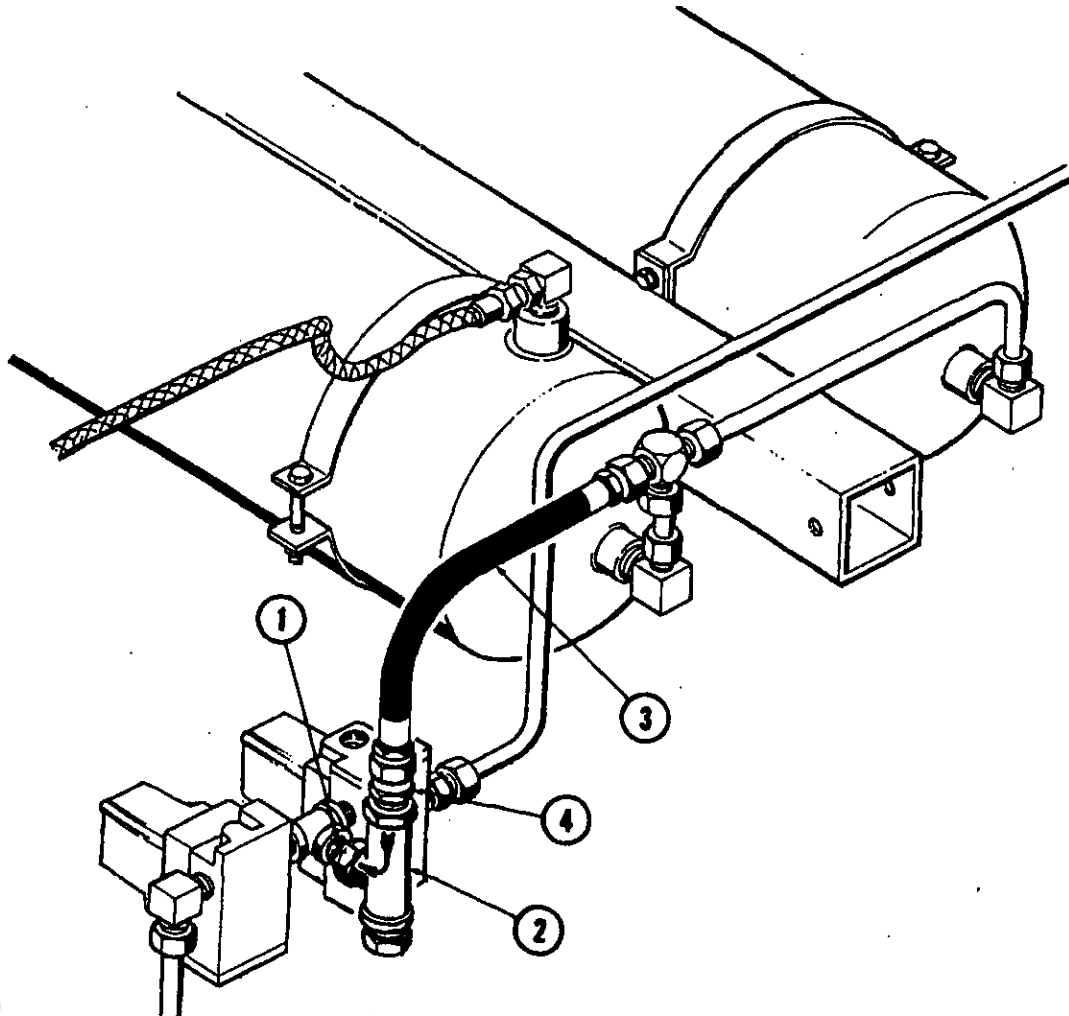



NUMBER: B402R1105-0

DATE: NOV. 25, 1991

SUPERSEDES:

---

---

## SERVICE BULLETIN

---

---

Effective Serial Number: All Units

Ride: WIPEOUT

Subject: Floor Handling

Chance Rides, Inc. supplies winches and hydraulic cylinders for raising and lowering the floor sections on the WIPEOUT amusement ride. These safety items must be used in order to prevent possible injury during set-up and tear-down. Decals have also been affixed to the ride at the factory, to warn persons not to stand in the path of the floors as they are being raised or lowered. Check to see that decals are in place before every set up.

The hydraulic cylinders for lowering the side floors are operated by the hand-held control box which installs into the receptacle labeled "floors". The receptacle is located on the curbside electrical box, just forward of the rear jack (see Illustration A).

NOTE: Care must be taken to assure the hand-held box is installed into the proper receptacle at the proper time. The inability to do this may result in damage to the floor cylinder turn buckle assemblies.

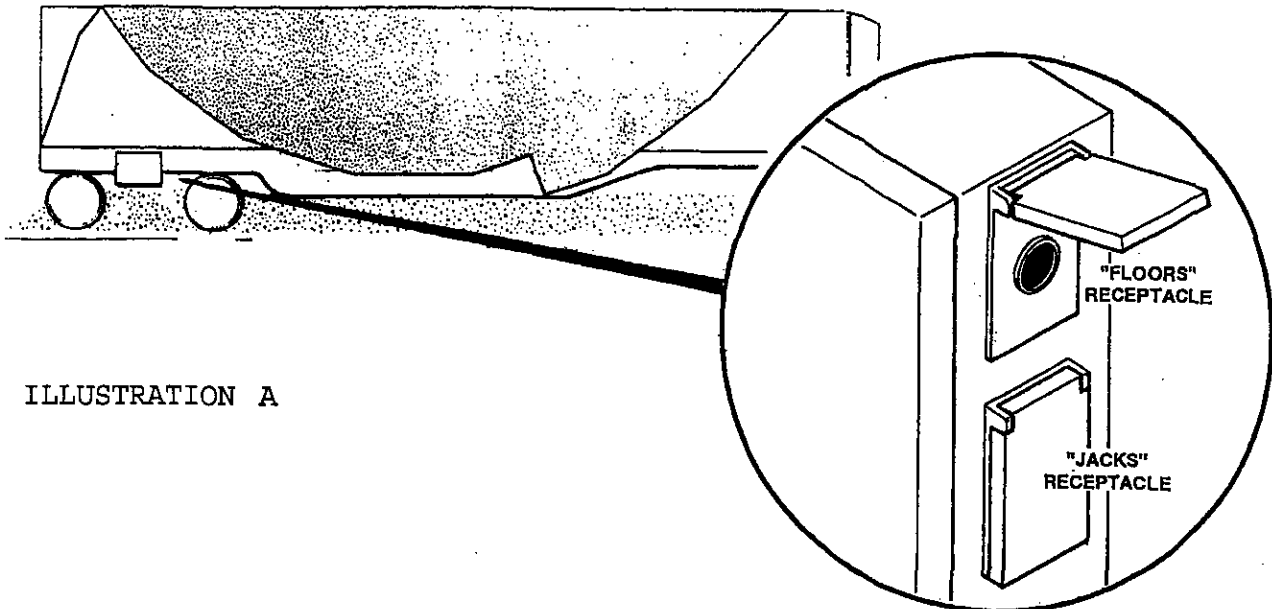

ILLUSTRATION A

Two winches are used to lower the front floor section. These winches are located under floor access panels in front of the operator's control house (see Illustration B). Once the front floor section has been lowered, the winches must be stowed and the access panels reinstalled.

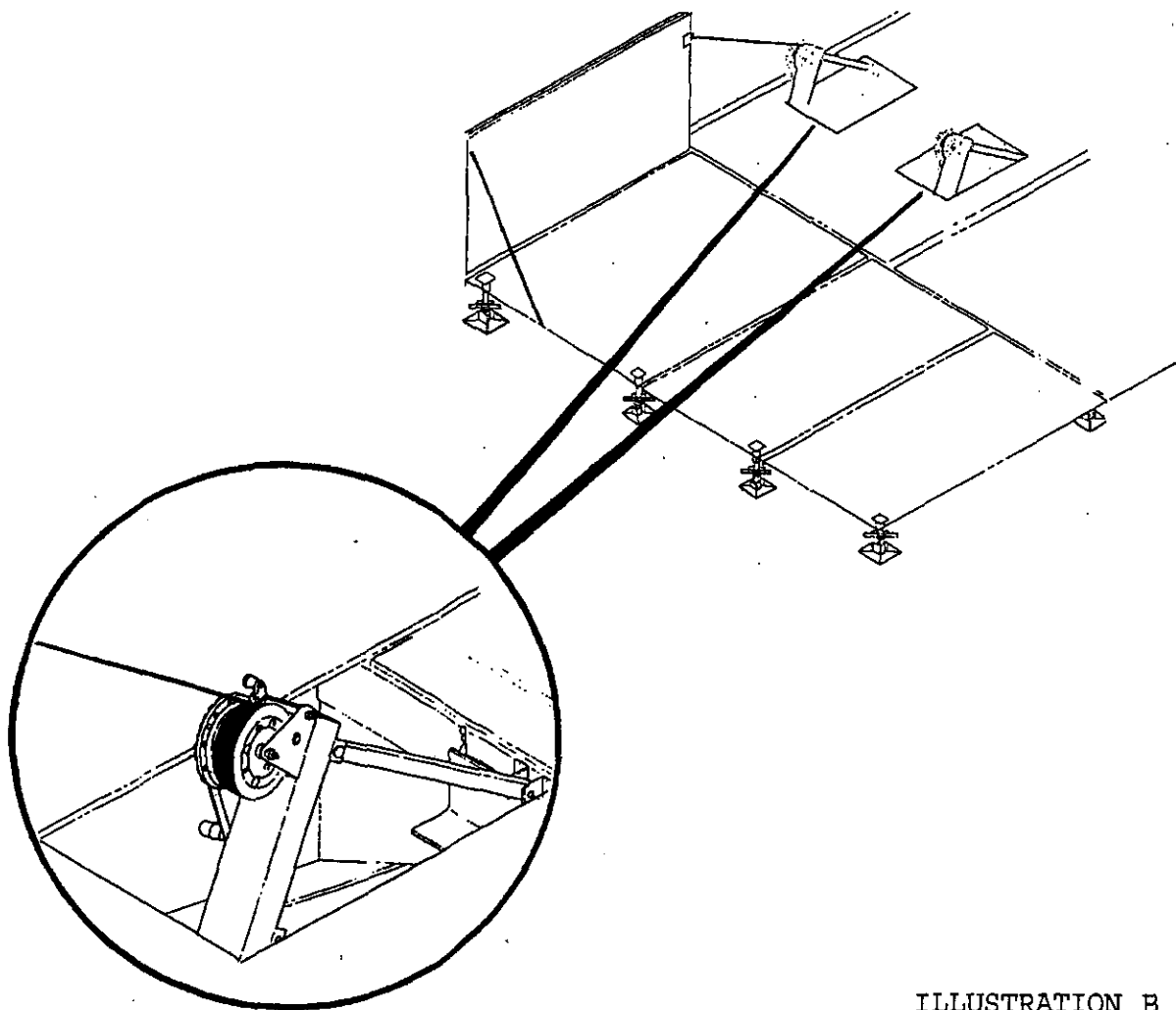

ILLUSTRATION B

**WARNING:** DO NOT ATTEMPT TO LOWER FLOORS WITHOUT THE USE OF THE WINCHES OR CYLINDERS. FAILURE TO COMPLY WITH THIS BULLETIN COULD RESULT IN INJURY.



NUMBER: B402R1110-0

DATE: DEC. 20, 1991

SUPERSEDES:

---

---

## SERVICE BULLETIN

---

---

Effective Serial Number: 40200190 through 40201891

Ride: WIPEOUT

Subject: Electrical Overload Protector  
Inspection/Replacement

Chance Rides, Inc. has become aware that incorrectly sized overload protectors, heaters and fuses, may have been installed on the above noted WIPEOUT amusement rides. The correct size heaters and fuses are necessary to prevent damage to the oil cooler motor, the pump motor for the leveling jacks, and the motor for the air compressor.

Chance Rides, Inc. requires all owner/operators of the above noted rides to perform the inspection and if necessary, the replacement of parts, as outlined in this bulletin.

All work must be performed by qualified personnel, capable of understanding the function of the parts and their proper installation.

### NOTICE

Use only those components authorized, specified or provided by Chance Rides, Inc.

Chance Rides, Inc. SPECIFICALLY DISCLAIMS ANY LIABILITY for losses associated with any unauthorized alterations and/or modifications or additions and installations of unauthorized components.

CAUTION: To prevent electrical shock, disconnect all power to the ride before performing any of the following work.
---

If a new heater or fuse is required, per this bulletin, they will be supplied free of charge, if ordered within 90 days of the date on this bulletin.



## INSPECTION/REPLACEMENT OF PUMP MOTOR HEATERS

Three heaters are located in box between rear leveling jack and the floor/jack receptacle box, located on the curbside of the trailer.

1. Remove cover from box by removing the one screw located at the bottom of the box.
2. Heaters are labeled as to size. Correct size is FH36. If any other size heater is present, order and install new heaters, part number 23324700.
3. To replace heaters, remove the two (2) screws securing the heater in place.
4. Reinstall cover after work is completed.

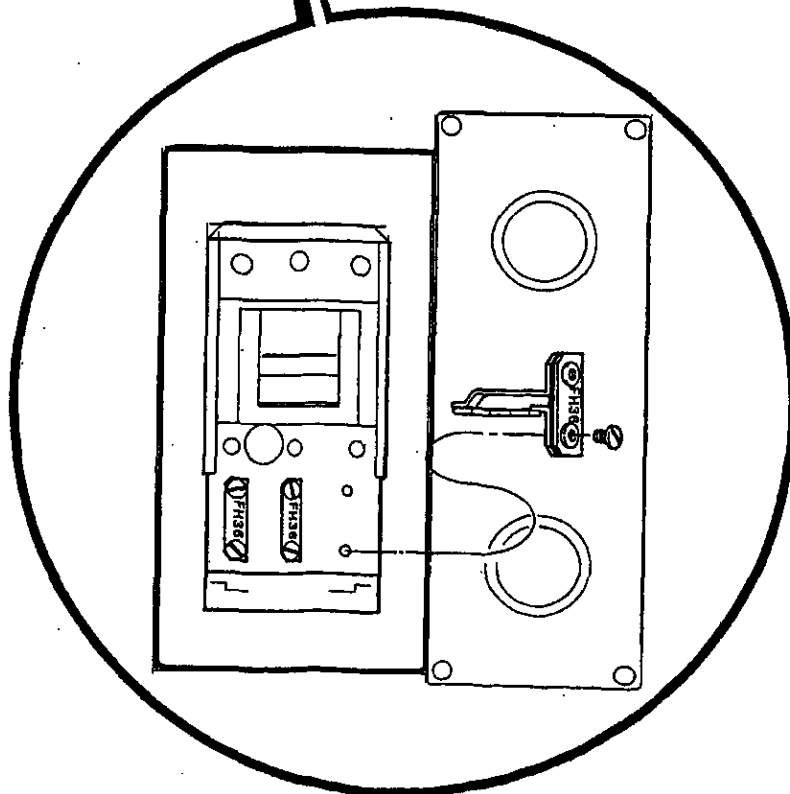
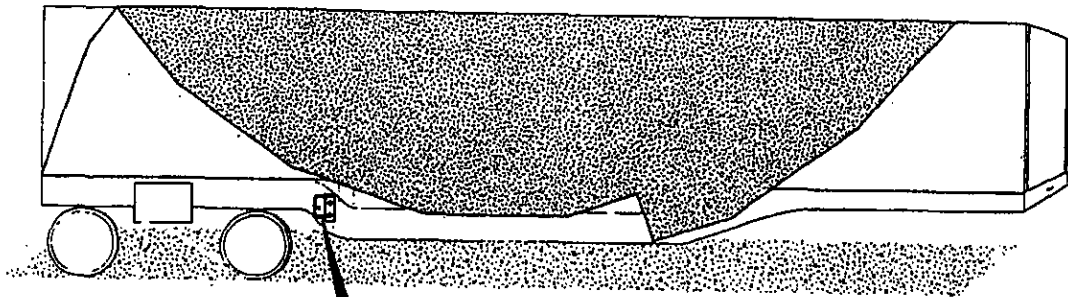

INSPECTION/REPLACEMENT OF OIL COOLER MOTOR HEATER & AIR COMPRESSOR FUSE

This heater and fuse are located in the motor control box, the left hand box with the on/off handle, mounted to the turret.

1. Turn power handle to off position and open door.
2. Locate single heater and inspect for correct heater size. Correct size is AR8.5. If any other size heater is present, order and install new heater, part number 23331702.
3. To replace heater, remove the two (2) screws securing the heater in place.
4. Locate fuse in fuse block directly above oil cooler motor heater and inspect for proper size. The fuse may have to be removed to determine size. The correct size is FNQ20. If any other fuse is present, order and install new fuse, part number 22149200.

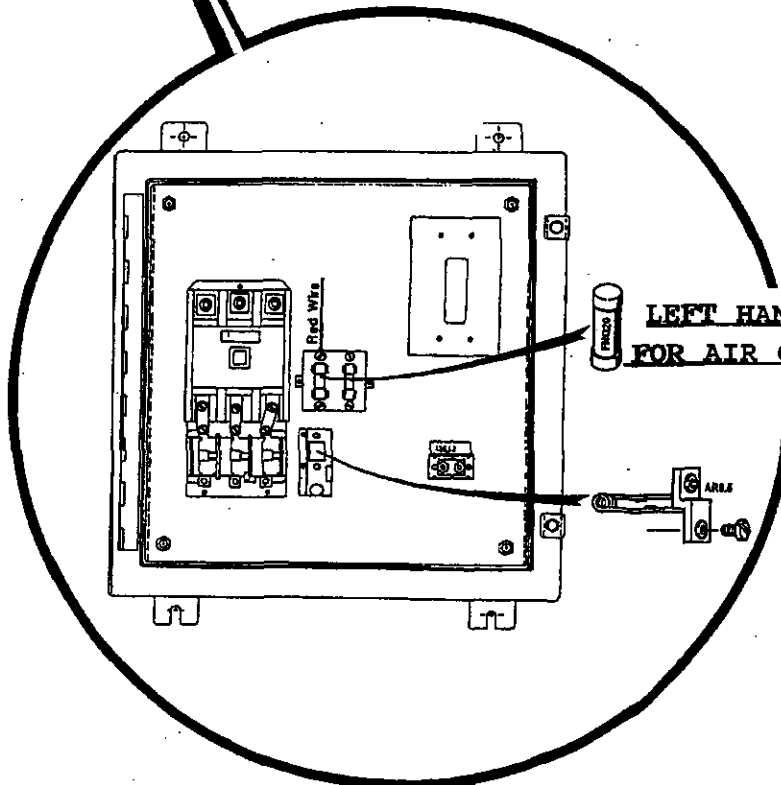
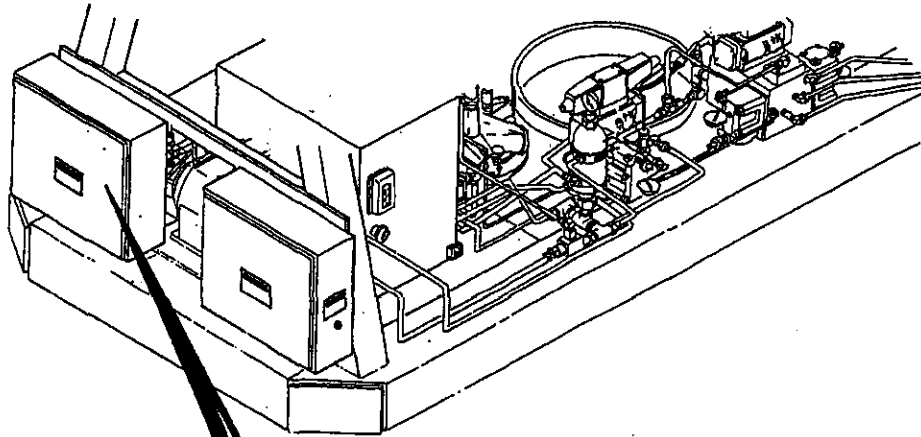

LEFT HAND FUSE ONLY IS  
FOR AIR COMPRESSOR MOTOR



NUMBER: B402R1109-0

DATE: JAN. 17, 1992

SUPERSEDES:

---

---

## SERVICE BULLETIN

---

---

Effective Serial Number: All Units

Ride: WIPEOUT

Subject: Hub Capscrew Torque Check

The Center hub section on the WIPEOUT amusement ride is secured to the bearing turntable on the boom by 28, Grade 8 hex-head capscrews. It is essential for the care of the equipment and safety of the passengers to maintain the proper torque on these capscrews. Chance Rides, Inc. requires all owner/operators of the above noted rides to perform the following check at least once per month during the operating season.

1. Verify that the 28 hardened washers under the capscrews securing the center hub section to the bearing turntable on the boom fit flush to the hub.
2. Using a torque wrench, check for proper torque of these 28 capscrews. Torque values for these capscrews should be 110 foot-pounds.

All work must be performed by qualified personnel, capable of understanding the function of the parts and their proper installation.

### NOTICE

Use only those components authorized, specified or provided by Chance Rides, Inc.

Chance Rides, Inc. SPECIFICALLY DISCLAIMS ANY LIABILITY for losses associated with any unauthorized alterations and/or modifications or additions and installations of unauthorized components.

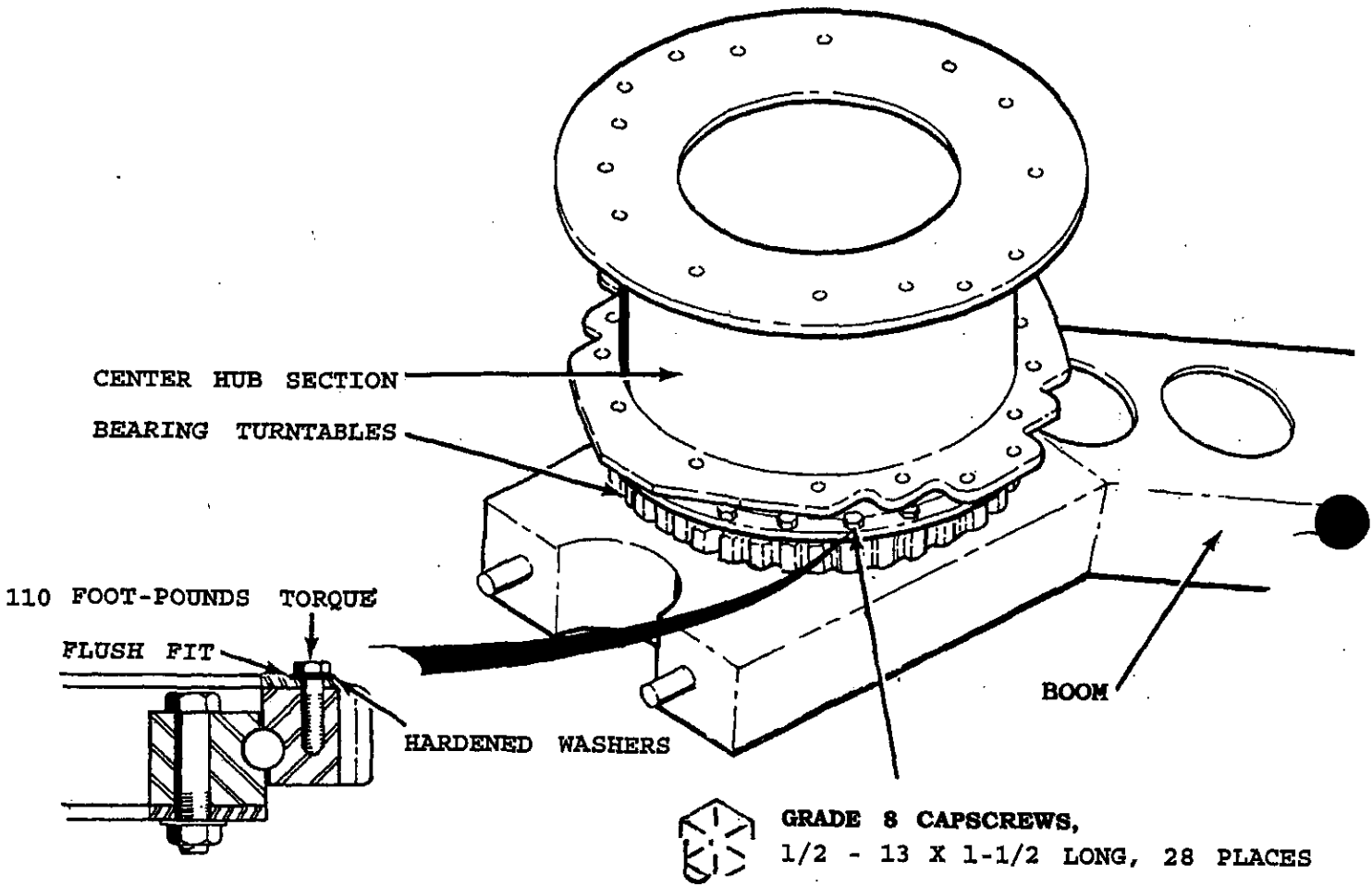

NOTE: If capscrews are removed and reinstalled with lubricated threads 90 foot-pounds must be maintained.



NUMBER: P402R1112-0

DATE: APRIL 10, 1992

SUPERSEDES:

---

---

# PRODUCT IMPROVEMENT NOTICE

---

---

Effective Serial Number: 40200190 - 40200290 and 40200491 - 40201991

Ride: WIPEOUT

Subject: Strobe Light Rework

Chance Rides, Inc. has improved the design of the strobe lights on the WIPEOUT amusement ride. These strobe lights are located on the underneath side of each sweep. Owners of the above noted rides can replace the original style strobe lights by ordering and installing kit number K402R1112-0. Each kit contains all parts and instructions necessary to rework one ride. Kits will be supplied at no charge, if ordered within 90 days of the date on this Product Improvement Notice.

All work must be performed by qualified personnel, capable of understanding the function of the parts and their proper installation.

#### NOTICE

Use only those components authorized, specified or provided by Chance Rides, Inc.

Chance Rides, Inc. SPECIFICALLY DISCLAIM ANY LIABILITY for losses associated with any unauthorized alterations and/or modifications or additions and installations of unauthorized components.

Contact the Chance Rides Customer Service Department regarding questions concerning this product improvement notice or the installation of Kit K402R1112-0.

Kit number K402R112-0 contains the following items:

<u>Part Number</u>	<u>Description</u>	<u>Qty</u>
28093400	Transformer	1
61115200	8-32 x 1/2 Machine Screw	4
64780400	8-32 Lock Nut	4
24082600	Strobe Light with Gasket	20
71110300	Cover	20
10000400	Yellow Twist Cap	41
K402R112-0	Drawing	1

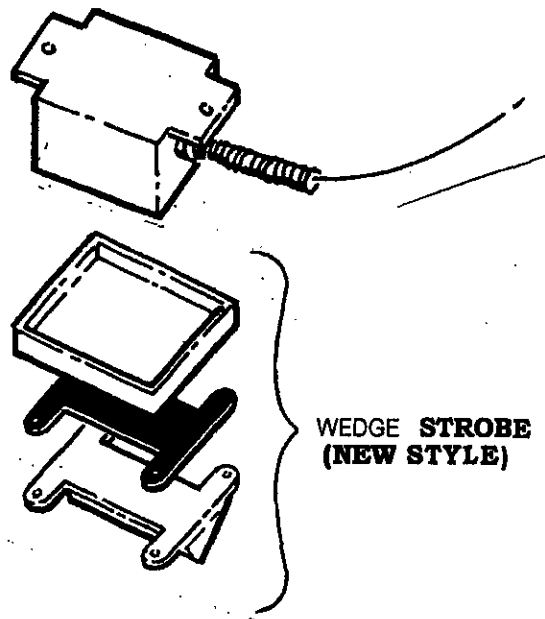
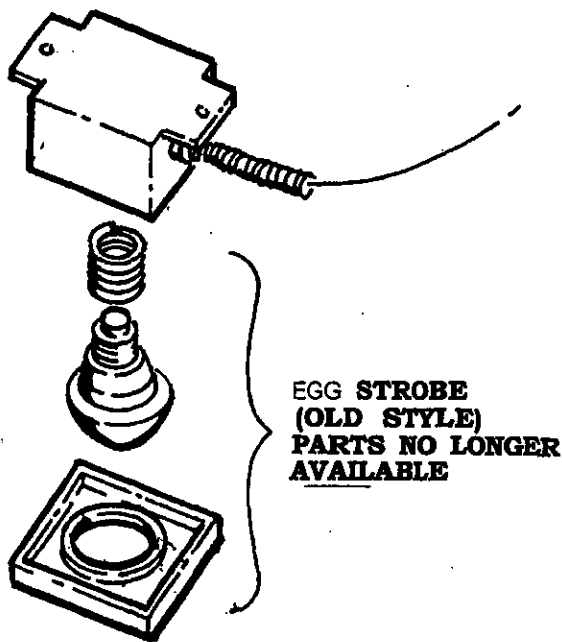



NUMBER: A402R1129-0

DATE: JUNE 25, 1993

SUPERSEDES:

---

---

## SAFETY ALERT

---

---

Effective Serial Number: 402-00190 through 402-02793

Ride: WIPEOUT

Subject: Boom Pivot Pin Capscrew  
Retainer Installation

<p><b>WARNING:</b> Failure to comply with this Safety Alert Bulletin can result in possible injury to passengers and/or structural damage.</p>
--

It has been determined by Chance Rides, Inc. that the hex head capscrews used to secure the boom pivot pin in place on the WIPEOUT amusement ride can become loose. If this happens, the pin may start to back out of the boom to turret joint. Damage to the ride and/or injury of passengers and personnel may result.

All owner/operators of the above noted rides are required to order and install the new locking hex head capscrews, part number 26432900 and capscrew retainers, part number 36018200. Two each are required per ride. Parts will be supplied at no charge if ordered within 90 days of the date on this bulletin.

Installation of these parts must be performed by qualified personnel, follow the instructions contained in this bulletin. Personnel must be capable of understanding the function of the parts and their proper installation. If there are any questions regarding installation instructions, contact the Chance Rides, Inc. Customer Service Department.

## INSTALLATION INSTRUCTIONS

1. Remove and discard the original capscrews and lock washers.
2. Install retainer and capscrew as illustrated, using 50 to 60 foot pounds with a torque wrench.
3. Bend the two tabs of the retainer down over the edges of the pin.
4. Bend the other tab of the retainer up against the flat side of the capscrew.

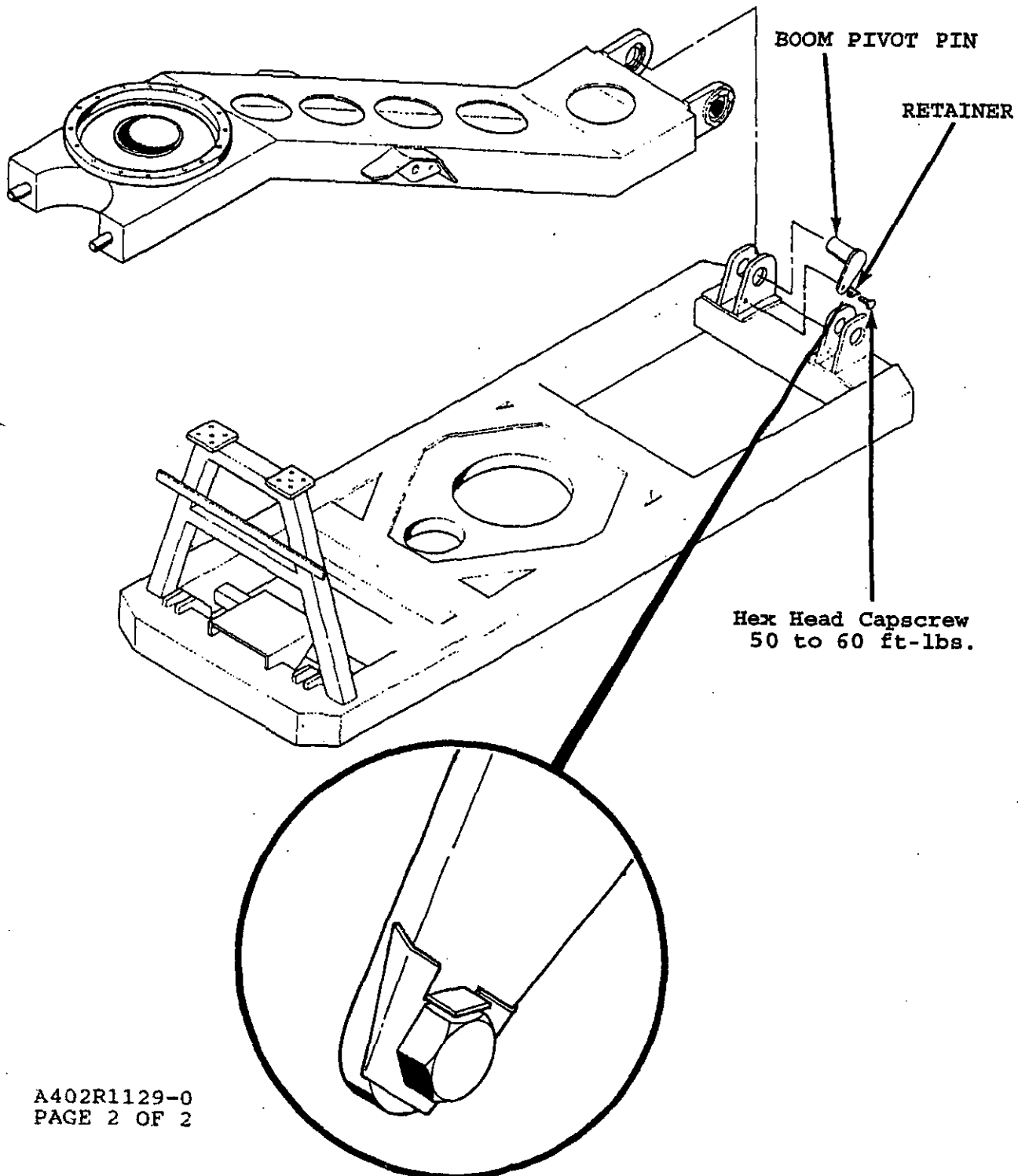





NUMBER: B402R1134-0

DATE: AUG. 6, 1993

SUPERSEDES:

---

---

## SERVICE BULLETIN

---

---

Effective Serial Number: 402-00190 through 402-02793

Ride: WIPEOUT

Subject: BRUSH HOLDER  
HOUSING LUBRICANT

Chance Rides, Inc. has become aware that it is possible for the brush holder assembly and the collector ring housing on the WIPEOUT amusement ride to seize. If this happens, damage to the equipment can occur. To help prevent the brush holder assembly and the collector ring housing from seizing, Chance Rides, Inc. has developed a special capscrew which when properly installed permits lubrication of this assembly.

All owner/operators of WIPEOUT rides listed above are required to order and install, as outlined in this bulletin the special hex head capscrew, part number 38984500. Two of these special hex head capscrews are required per ride, one for each of the two collector ring housing assemblies. These parts are available at no charge if ordered within 90 days of the date on this bulletin.

Once the special hex head capscrews have been properly installed, lubrication of the housings can be accomplished. Using a number 2 lithium base grease, lubricate housings monthly by applying grease, rotating ride one quarter turn, applying more grease, rotating another one quarter turn and continuing process until housings have been lubricated all the way around.

All work must be performed by qualified personnel, capable of understanding the function of the parts and their proper installation.

### NOTICE

Use only those components authorized, specified or provided by Chance Rides, Inc.

Chance Rides, Inc. SPECIFICALLY DISCLAIMS ANY LIABILITY for losses associated with any unauthorized alterations and/or modifications or additions and installations of unauthorized components.

INSTALLATION INSTRUCTION - HEX HEAD CAPSCREWS

PART NUMBER 38984500

1. Turn power off to ride and disconnect the main power supply to the ride.
2. Remove the covers from the brush holder and collector ring assemblies. Retain the original hardware.
3. Remove and discard one of the 3/8 - 16 x 3/4 long hex head capscrews in each of the two brush holder assemblies.
4. Using a number 11 drill bit, drill a hole at the bottom of the hole from which the hex head cap screw was removed in step 3. Drill through the brush holder assembly and the nylon bushing.

NOTE: DO NOT DRILL INTO THE COLLECTOR RING HOUSING

5. Using a torque wrench, install the new hex head capscrews to 19-24 foot pounds.
6. Lubricate as specified in this bulletin.
7. Install the cover over the brush holder and collector ring housing assemblies using the original hardware.

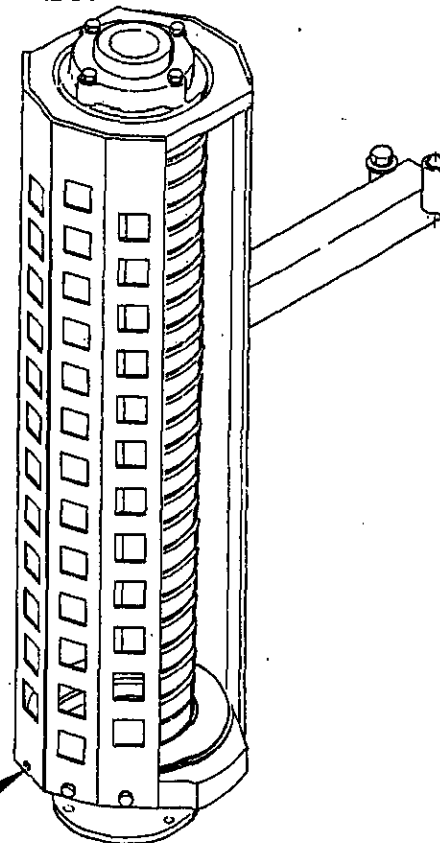
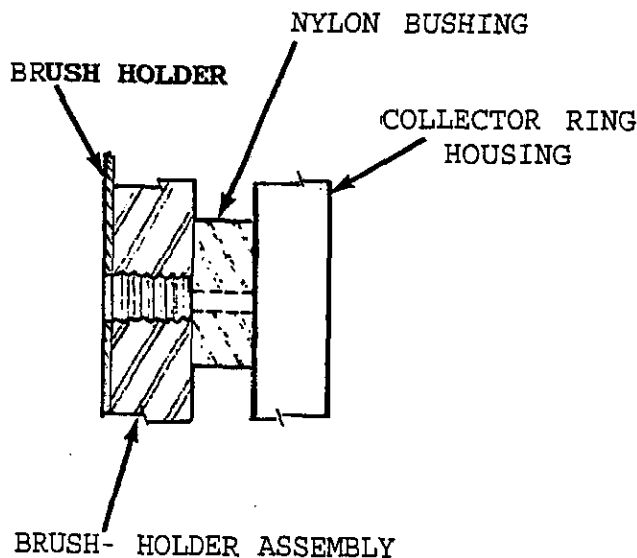

NOTE: LOWER COLLECTOR RING ASSEMBLY SHOWN. UPPER COLLECTOR RING ASSEMBLY OPPOSITE



NUMBER: B402R1164-0

DATE: AUG. 15, 1994

SUPERSEDES:

---

---

## SERVICE BULLETIN

---

---

Effective Serial Number: All Units

Ride: WIPEOUT

Subject: Turret Drive Inspection

Chance Rides, Inc. has become aware that the socket head cap screws that secure the drive pinion to the bearing keeper for the turret drive of the WIPEOUT amusement ride can loosen. If this occurs, the pinion will become loose and could drop out of position, resulting in damage to mechanical parts.

Chance Rides, Inc. requires all owner/operators of the above noted amusement rides to perform the inspection of the turret drive as outlined in this bulletin.

All work must be performed by qualified personnel, capable of understanding the function of the parts and their proper installation.

### NOTICE

Use only those components authorized, specified or provided by Chance Rides, Inc.

Chance Rides Inc. SPECIFICALLY DISCLAIMS ANY LIABILITY for losses associated with any unauthorized alterations and/or modification or additions and installations of unauthorized components.

### INSPECTION PROCEDURES:

1. Raise and block boom to give access to the turret drive motor and to stabilize boom while working under it.

**WARNING:** Heavy items falling or descending out of control can cause injury to personnel. Make sure the boom is adequately secured before attempting to work under it.

2. Remove the five (5) 5/8-11 x 2 1/2 inch hex head cap screws that hold the hydraulic motor in place.
3. Raise the hydraulic motor to gain access to the bearing keeper.

**WARNING:** Lifting heavy items can cause injury to personnel. Care must be taken when raising the hydraulic motor, which weighs approximately 150 pounds.

**Note:** The hydraulic lines may need to be removed from the motor in order to raise the motor out of the way.

4. Check the torque (24 - 30 ft. lbs.) of the six (6) socket head cap screws holding the bearing keeper to the pinion.
5. If any of these socket head cap screws are loose, perform the following procedure:
  - a) remove the socket head cap screws
  - b) clean the threads
  - c) apply Blue Loctite 242 to the threads of the socket head cap screws and reinstall using 22 - 27 ft. lbs. of torque
6. Reinstall the hydraulic motor with the five (5) 5/8-11 x 2 inch hex head cap screws and 95 to 115 ft. lbs. of torque.

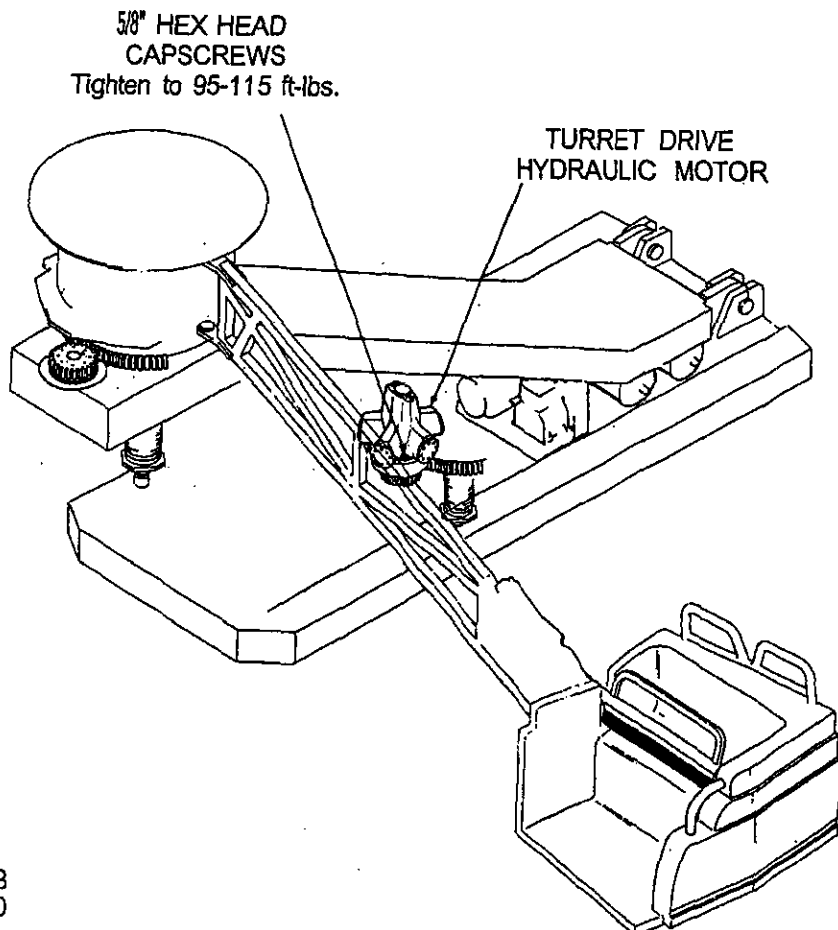

SOCKET HEAD  
CAPSCREWS  
Apply Loctite 242 Blue  
to threads. Tighten to  
22-27 ft-lbs.

BEARING KEEPER

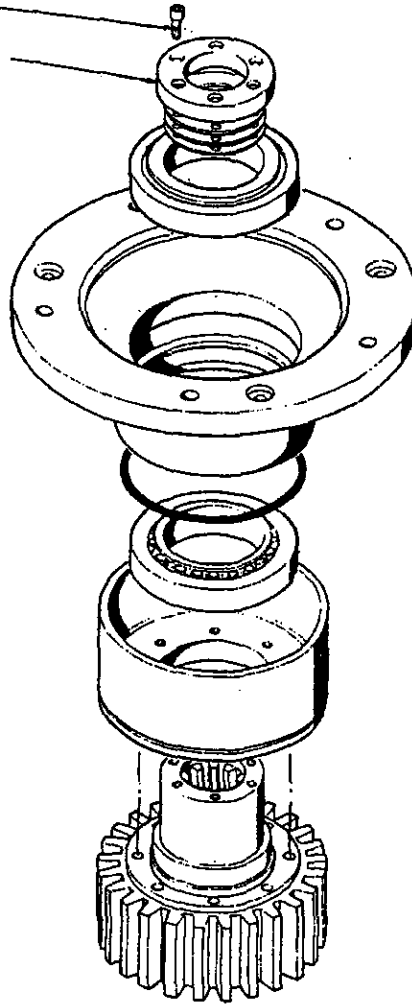

01-03 BFi



The World's Ride Company

CHANCE RIDES, INC.  
4219 Irving  
Wichita, KS 67277-2328  
U.S.A.  
Phone: 1-800-242-6231 • FAX: 1-316-942-7416  
Website: www.rides.com

Bulletin No:	B402R1255-A
Release Date:	May 24, 2001
Effective Date:	May 24, 2001
Supersedes:	B402R1255-0
Completion Date:	Immediately
Page:	1 of 7

# SERVICE BULLETIN

Ride Manufacturer: CHANCE RIDES, INC.

Affected Production Dates: All

Ride Name: WIPEOUT

Affected Serial Nos.: All units

Model No.: 402

Abstract of Issue:  
Lap Bar Latch Inspection and Maintenance

Reason For Release:

Service Bulletin B402R1255-0 is superseded by this bulletin and is no longer in effect.

Chance Rides, Inc. has become aware of an incident where a lap bar on the WIPEOUT amusement ride opened during the operation of the ride. This was due to incomplete engagement of the latching mechanism for the lap bar. In order to maintain the original level of passenger safety, all lap bar latches must be maintained per the manufacturer's specifications.

This bulletin is being released to provide detailed inspection and maintenance instructions on the lap bar latch mechanism. Operation of the ride with incorrectly maintained or improperly adjusted lap bar latches can result in serious personal injury to passengers.

Detail of Issue:

Chance Rides, Inc. requires all owner/operators of the above noted WIPEOUT amusement rides to immediately inspect the lap bar latches on every vehicle to ensure that they operate exactly as intended.

The lap bar latches must be maintained per the manufacturer's specifications to provide safety to the passengers. The procedures detailed in this bulletin must be performed daily, and anytime the latch is disassembled or replacement parts are installed.

Post-it® Fax Note 7671

*06/05/01*

To	<i>Ride Inspectors</i>	Date	<i>06/05/01</i>	# of Pages	<i>7</i>
Co./Dept.		From	<i>Mike Rinehart</i>		
Phone #		Co.	<i>FIA, D&amp;S</i>		
Fax #		Phone #	<i>850-922-2330</i>		
		Fax #	<i>850-413-8513</i>		

**CHANCE RIDES, INC.**

4219 Irving  
Wichita, KS 67277-2328

U.S.A.

Phone: 1-800-242-6231 • FAX: 1-316-942-7416

Website: [www.rides.com](http://www.rides.com)

E-mail: [rides@rides.com](mailto:rides@rides.com)

Bulletin No: B402R1255-A

Release Date: May 24, 2001

Effective Date: May 24, 2001

Supersedes: B402R1255-0

Completion Date: Immediately

Page: 2 of 7

Ride Manufacturer: CHANCE RIDES, INC.

Affected Production Dates: All

Ride Name: WIPEOUT

Affected Serial Nos.: All units

Model No.: 402

**Action to be taken:**

All work must be performed by qualified personnel, capable of understanding the function of the parts and their proper installation.

**NOTICE**

Use only those components authorized, specified or provided by Chance Rides, Inc.

Chance Rides, Inc. **SPECIFICALLY DISCLAIMS ANY LIABILITY** for losses associated with any unauthorized alterations and/or modifications or additions and installations of unauthorized components.

**Lap Bar Latch Inspection / Maintenance Procedure**

Perform the following inspection on every lap bar latch immediately. Thereafter, perform the procedure daily, and anytime the latch is disassembled or replacement parts are installed.

**NOTE:** Perform each step in the sequence given. Refer to the illustrations for identification of specific components.

*If, for any reason, the lap bar latches cannot be adjusted exactly as described, do not operate the ride. Contact the Chance Customer Service Department immediately.*

1. Make sure the low air warning devices are operating properly. The ride is equipped with an indicator light and an audible alarm which must come on when air pressure at the tanks is below 65-70 psi.
2. The air pressure to the lap bar lock cylinders must be set to 40 psi. If necessary, adjust the air pressure at the regulator, located near the compressor.



**CHANCE RIDES, INC.**  
 4219 Irving  
 Wichita, KS 67277-2328  
 U.S.A.  
 Phone: 1-800-242-6231 • FAX: 1-316-942-7416  
 Website: [www.rides.com](http://www.rides.com)  
 E-mail: [rides@rides.com](mailto:rides@rides.com)

Bulletin No:	B402R1255-A
Release Date:	May 24, 2001
Effective Date:	May 24, 2001
Supersedes:	B402R1255-0
Completion Date:	Immediately
Page:	3 of 7

Ride Manufacturer:	CHANCE RIDES, INC.	Affected Production Dates:	All
Ride Name:	WIPEOUT	Affected Serial Nos.:	All units
Model No.:	402		

Action to be taken (continued):

3. Check that the lap bar is level in relation to the seat when pushed completely down. If necessary, loosen the jam nut and adjust the down stop, then tighten the jam nut.

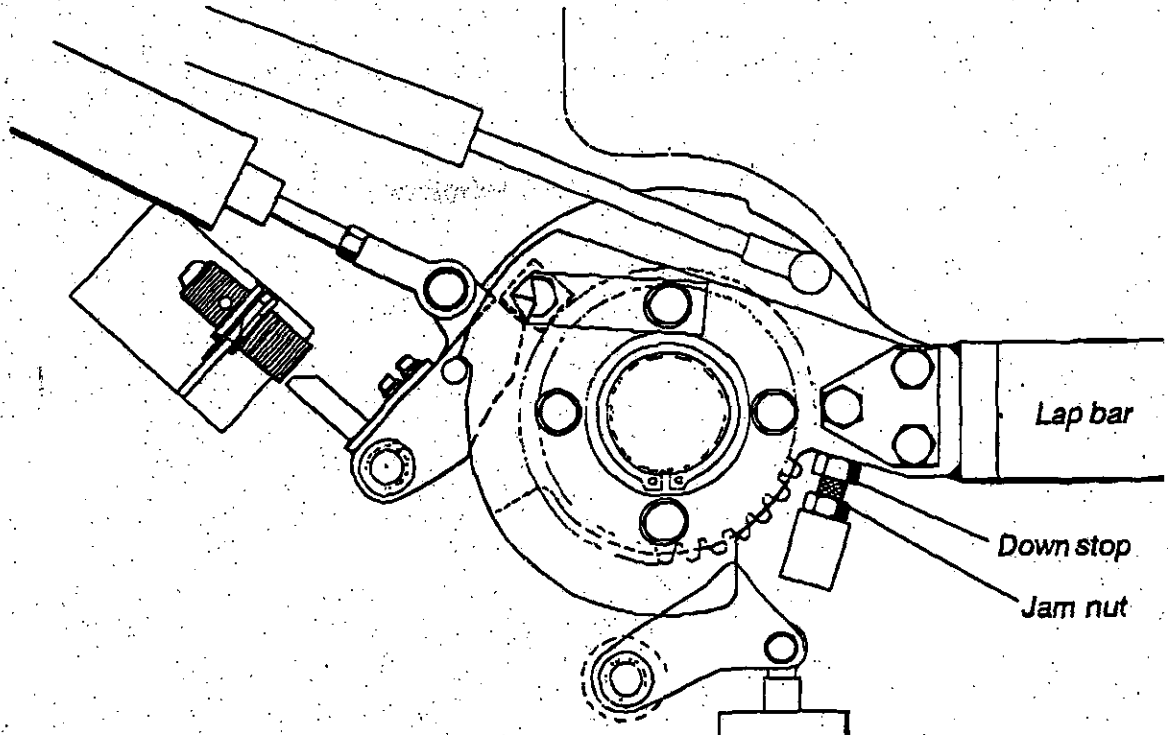

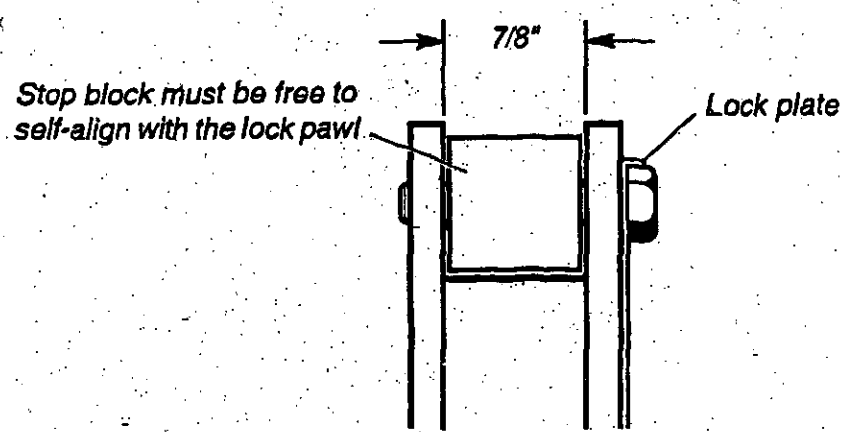

	<b>CHANCE RIDES, INC.</b> 4219 Irving Wichita, KS 67277-2328 U.S.A. Phone: 1-800-242-6231 • FAX: 1-316-942-7416 Website: <a href="http://www.rides.com">www.rides.com</a> E-mail: <a href="mailto:rides@rides.com">rides@rides.com</a>	Bulletin No: B402R1255-A
		Release Date: May 24, 2001
		Effective Date: May 24, 2001
		Supersedes: B402R1255-0
		Completion Date: Immediately
Page: 4 of 7		
Ride Manufacturer: CHANCE RIDES, INC.		Affected Production Dates: All
Ride Name: WIPEOUT		Affected Serial Nos.: All units
Model No.: 402		
Action to be taken (continued):		
<p>4. Check the engagement of the lock pawl to the stop block. The following conditions must ALL exist when the lock pawl and stop block are correctly adjusted.</p> <ul style="list-style-type: none"> <li>• When the lock pawl is fully engaged, the milled slot in the lock pawl must be aligned with the corner of the stop block, and the dowel must engage in the recessed area as shown. If the lock pawl does not engage deeply enough, loosen the jam nut and turn the rod end of the air cylinder to lengthen. The cylinder rod must engage at least seven threads of the rod end. Tighten the jam nut.</li> <li>• Check the clearance between the locking pawl and stop block. These parts must fit as close as possible and still function smoothly without binding as the lock pawl engages and disengages. If necessary, adjustment can be accomplished by removing the hex head capscrew securing the stop block and rotating the stop block as required (the hole in the stop block is drilled off center to facilitate adjustment). <b>DO NOT GRIND OR OTHERWISE MODIFY ANY OF THESE PARTS.</b></li> <li>• Make sure the stop block can move between the plates to self-align with the lock pawl. The space between the plates must be maintained at 7/8". <b>DO NOT OVER TIGHTEN THE HEX HEAD CAPSCREW.</b> This will cause the stop block to bind. When the capscrew is snug, bend the lock plate tabs over the flats of the capscrew to prevent it from turning.</li> </ul>		
		



**CHANCE RIDES, INC.**  
 4219 Irving  
 Wichita, KS 67277-2328  
 U.S.A.  
 Phone: 1-800-242-6231 • FAX: 1-316-942-7416  
 Website: [www.rides.com](http://www.rides.com)  
 E-mail: [rides@rides.com](mailto:rides@rides.com)

Bulletin No: B402R1255-A  
 Release Date: May 24, 2001  
 Effective Date: May 24, 2001  
 Supersedes: B402R1255-0  
 Completion Date: Immediately  
 Page: 5 of 7

Ride Manufacturer: CHANCE RIDES, INC. Affected Production Dates: All

Ride Name: WIPEOUT Affected Serial Nos.: All units

Model No.: 402

Action to be taken (continued):

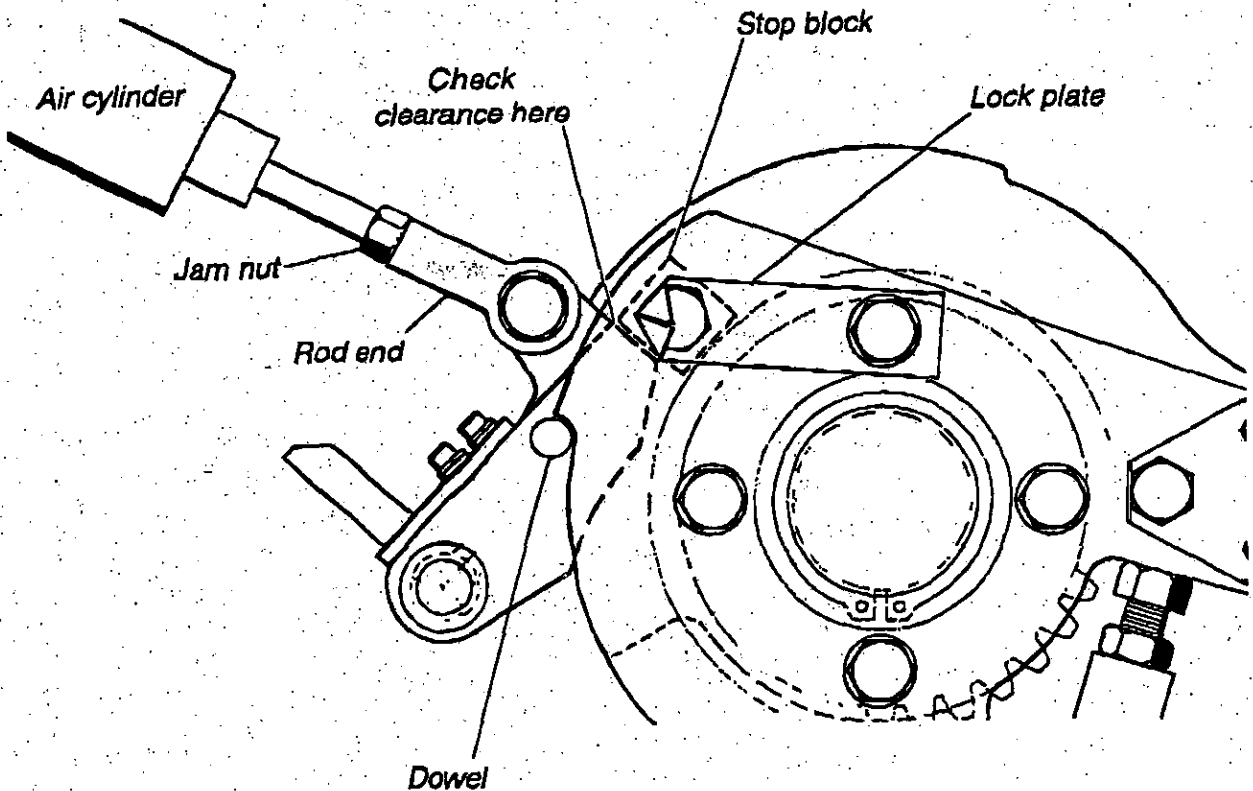

	<b>CHANCE RIDES, INC.</b> 4219 Irving Wichita, KS 67277-2328 U.S.A. Phone: 1-800-242-6231 • FAX: 1-316-942-7416 Website: <a href="http://www.rides.com">www.rides.com</a> E-mail: <a href="mailto:rides@rides.com">rides@rides.com</a>	Bulletin No: B402R1255-A
		Release Date: May 24, 2001
		Effective Date: May 24, 2001
		Supersedes: B402R1255-0
		Completion Date: Immediately
Ride Manufacturer: CHANCE RIDES, INC. Affected Production Dates: All		Page: 6 of 7
Ride Name: WIPEOUT Affected Serial Nos.: All units		
Model No.: 402		
Action to be taken (continued):		
<p>5. Check the proximity switch as follows:</p> <ul style="list-style-type: none"> <li>• Check the gap between the proximity switch and the adjustable block. The gap must be <math>3/32"</math>. If adjustment is necessary, bend up the locking tabs from the switch adjusting nuts and loosen the nuts. Adjust the position of the switch to obtain the correct gap, then tighten the adjusting nuts and bend up the locking tabs over the flats of each nut.</li> <li>• Check the position of the adjustable block. The block is correctly adjusted when the indicator light on the switch is on when the lock pawl is fully engaged. When the locking pawl is moved slightly from the fully engaged position, the light must go out.</li> </ul> <p><b>NOTE:</b> The indicator light on the sweep comes on and off opposite of the indicator light on the switch.</p> <p>If adjustment is required, loosen the two screws on the adjustable block. The block has slotted holes and can be moved up or down as required to obtain the correct adjustment. Tighten the screws on the adjustable block.</p> <ul style="list-style-type: none"> <li>• Check the operation of the lap bar interlock system exactly as described in the <i>WIPEOUT Service Manual</i> (see page 16 in the "Maintenance Manual" section). This procedure requires two people.</li> </ul> <p>6. With the ride ready to operate, close and latch the lap bars. Make sure each air cylinder is holding its lock pawl in the fully engaged position. Try to release the lap bar latch by pulling the manual release lever toward the cylinder. It must not be easily retracted by hand.</p>		



**CHANCE RIDES, INC.**

4219 Irving  
Wichita, KS 67277-2328  
U.S.A.

Phone: 1-800-242-6231 • FAX: 1-316-942-7416

Website: [www.rides.com](http://www.rides.com)

E-mail: [rides@rides.com](mailto:rides@rides.com)

Bulletin No: B402R1255-A

Release Date: May 24, 2001

Effective Date: May 24, 2001

Supersedes: B402R1255-0

Completion Date: Immediately

Page: 7 of 7

Ride Manufacturer: CHANCE RIDES, INC.

Affected Production Dates: All

Ride Name: WIPEOUT

Affected Serial Nos.: All units

Model No.: 402

Action to be taken (continued):

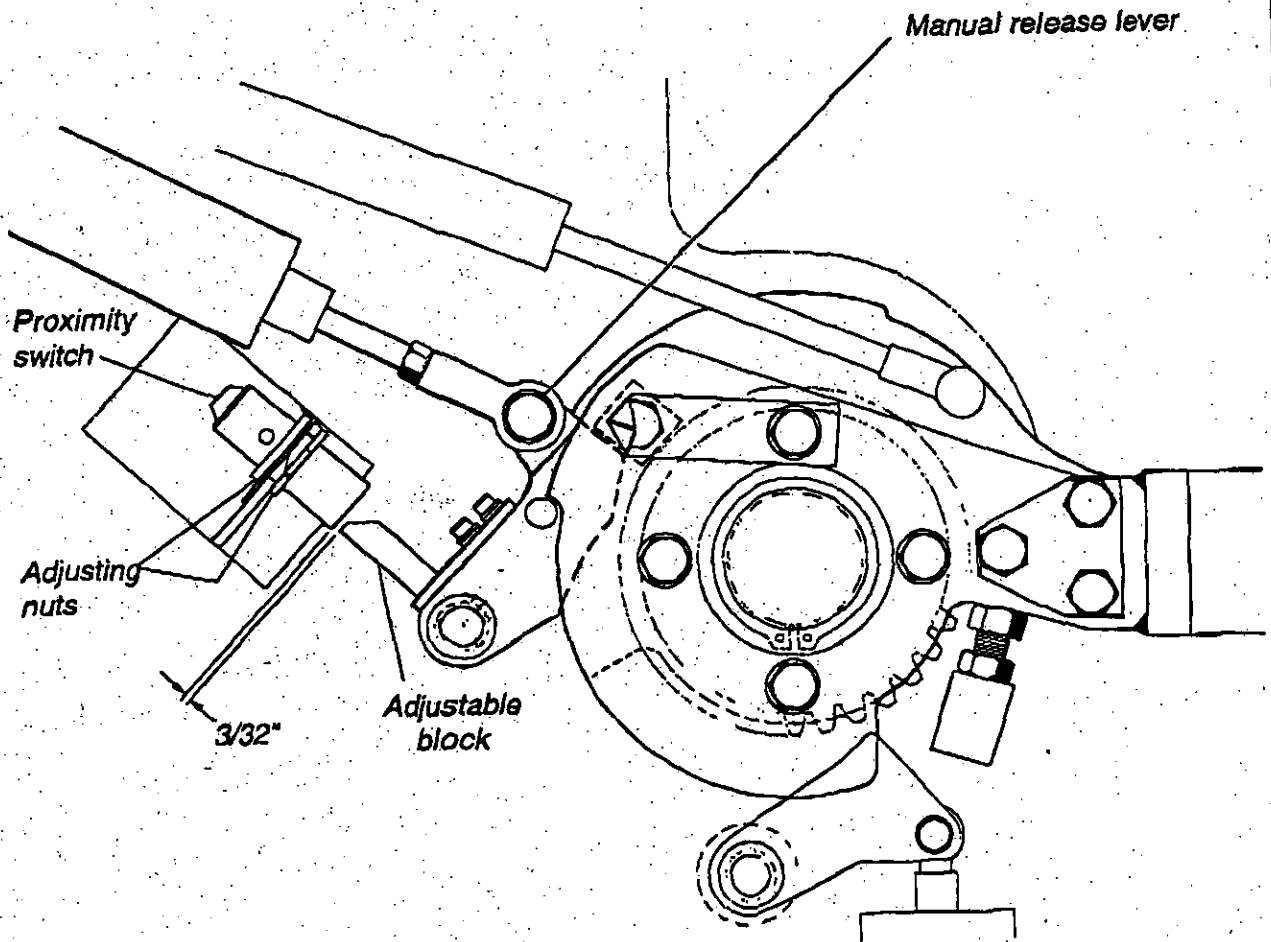



**CHANCE RIDES MANUFACTURING, INC.**  
4200 Walker  
Wichita, KS 67277-2328  
U.S.A.  
Phone: 1-316-942-7411 • FAX: 1-316-942-2012  
Website: [www.rides.com](http://www.rides.com)  
E-mail: [rides@rides.com](mailto:rides@rides.com)

Bulletin No: B402CRM109-0  
Release Date: December 20, 2002  
Effective Date: Immediately  
Supersedes: N/A  
Completion Date: March 20, 2003  
Page: 1 of 3

# SERVICE BULLETIN

Ride Manufacturer: CHANCE RIDES, INC.

Affected Production Dates: All

Ride Name: WIPEOUT

Affected Serial Nos.: All Units

Model No.: 402

Abstract of Issue:  
Lap Belt Kit

#### Reason For Release:

Chance Rides Manufacturing, Inc. has become aware that on the WIPEOUT amusement ride, a passenger can move into an unsafe position in the seat after the lap bar is closed and locked. If this happens while the ride is in operation, serious personal injury to the passenger and bystanders can result.

As an additional measure of safety, a lap belt system has been developed which provides a supplemental restraint device to be used in conjunction with the existing passenger restraint system. Two lap belt kits are available, one with manually adjustable belts, the other with automatic retractable belts.

#### Action to be Taken:

Chance Rides Manufacturing, Inc. requires that all owner/operators of the above noted WIPEOUT amusement rides install one of these lap belt kits within 90 days of the release date of this bulletin. Complete installation instructions are provided with the kit, as well as revised operation and maintenance procedures.

Order and install either the Manually Adjustable Lap Belt Kit (part number K402CRM109-0) or the Retractable Lap Belt Kit (part number K402CRM109-1). These kits will be offered at a reduced price if ordered within 90 days of the release date of this bulletin.

All work must be performed by qualified personnel, capable of understanding the function of the parts and their proper installation. Use only those components authorized, specified or provided by Chance Rides Manufacturing, Inc. All applicable OSHA safety standards and safe industry practices must be observed.

Observe all safety information contained in the manufacturer's manuals. Make available this bulletin and all related technical information to personnel using the equipment.

Chance Rides Manufacturing, Inc. issues notifications for the benefit of owners of amusement rides manufactured by Chance Rides Manufacturing, Inc. As a service to the industry, and in the interest of employee and public safety, Chance Rides Manufacturing, Inc. also issues notifications for the benefit of owners of amusement ride equipment for which the manufacturer no longer exists, such as the Allan Herschell Company, Chance Manufacturing Co., Inc., Chance Rides, Inc., etc. In doing so, Chance Rides Manufacturing, Inc. does not assume liability for losses associated with amusement ride equipment built by manufacturers other than Chance Rides Manufacturing, Inc.



**CHANCE RIDES MANUFACTURING, INC.**  
 4200 Walker  
 Wichita, KS 67277-2328  
 U.S.A.  
 Phone: 1-316-942-7411 • FAX: 1-316-942-2012  
 Website: [www.rides.com](http://www.rides.com)  
 E-mail: [rides@rides.com](mailto:rides@rides.com)

Bulletin No: B402CRM109-0  
 Release Date: December 20, 2002  
 Effective Date: Immediately  
 Supersedes: N/A  
 Completion Date: March 20, 2003  
 Page: 2 of 3

Ride Manufacturer: CHANCE RIDES, INC.      Affected Production Dates: All

Ride Name: WIPEOUT      Affected Serial Nos.: All Units

Model No.: 402

Detail of issue (continued):

**For the MANUALLY ADJUSTABLE LAP BELT KIT, Order part number K402CRM109-0, which contains the following:**

<u>Part Number</u>	<u>Component</u>	<u>Quantity</u>
402-127-030	LAP BELT - Manually Adjustable . . . . .	40
402-127-001	LAP BELT MOUNT WELDMENT - R.H. . . . .	10
402-127-002	LAP BELT MOUNT WELDMENT - L.H. . . . .	10
402-127-021	CLAMP PLATE - LAP BELT MOUNT (Saddle) . . . . .	20
402-127-022	CLAMP PLATE - LAP BELT MOUNT (Flat) . . . . .	20
60786800	HHCS 3/8-16 x 1-3/4 Grade 8 . . . . .	20
60786400	HHCS 3/8-16 x 1-1/4 Grade 8 . . . . .	40
64813502	LOCKNUT - ESSNA 3/8-16 Grade 8 . . . . .	60
68553100	WASHER - FLAT 3/8 H.T. . . . .	120
60701200	HHCS 1/4-20 x 2 Grade 5 . . . . .	180
60700400	HHCS 1/4-20 x 1 Grade 5 . . . . .	80
64780800	LOCKNUT N/I 1/4-20 ZP . . . . .	260
68530200	WASHER - SAE 1/4 Z/P . . . . .	520
402-127-031	SLOT TEMPLATE FOR R.H. SEAT . . . . .	1
402-127-032	SLOT TEMPLATE FOR L.H. SEAT . . . . .	1
K402CRM109-0	INSTALLATION INSTRUCTIONS . . . . .	1



**CHANCE RIDES MANUFACTURING, INC.**  
 4200 Walker  
 Wichita, KS 67277-2328  
 U.S.A.  
 Phone: 1-316-942-7411 • FAX: 1-316-942-2012  
 Website: [www.rides.com](http://www.rides.com)  
 E-mail: [rides@rides.com](mailto:rides@rides.com)

Bulletin No: B402CRM109-0  
 Release Date: December 20, 2002  
 Effective Date: Immediately  
 Supersedes: N/A  
 Completion Date: March 20, 2003  
 Page: 3 of 3

Ride Manufacturer: CHANCE RIDES, INC. Affected Production Dates: All

Ride Name: WIPEOUT Affected Serial Nos.: All Units

Model No.: 402

Detail of Issue (continued):

**For the RETRACTABLE LAP BELT KIT, Order part number K402CRM109-1, which contains the following:**

<u>Part Number</u>	<u>Component</u>	<u>Quantity</u>
20545704	LAP BELT - Retractable	40
402-127-001	LAP BELT MOUNT WELDMENT - R.H.	10
402-127-002	LAP BELT MOUNT WELDMENT - L.H.	10
402-127-021	CLAMP PLATE - LAP BELT MOUNT (Saddle)	20
402-127-022	CLAMP PLATE - LAP BELT MOUNT (Flat)	20
60849400	HHCS 1/2-13 x 1-3/4 Grade 8	20
64813505	LOCKNUT - ESSNA 1/2-13 Grade 8	20
668531600	WASHER - FLAT 1/2 Z/P	40
60786400	HHCS 3/8-16 x 1-1/4 Grade 8	40
64813502	LOCKNUT - ESSNA 3/8-16 Grade 8	40
68553100	WASHER - FLAT 3/8 H.T.	80
60701200	HHCS 1/4-20 x 2 Grade 5	180
60700400	HHCS 1/4-20 x 1 Grade 5	80
64780800	LOCKNUT N/I 1/4-20 ZP	260
68530200	WASHER - SAE 1/4 Z/P	520
402-127-031	SLOT TEMPLATE FOR R.H. SEAT	1
402-127-032	SLOT TEMPLATE FOR L.H. SEAT	1
K402CRM109-1	INSTALLATION INSTRUCTIONS	1



**CHANCE RIDES MANUFACTURING, INC.**  
4200 Walker  
Wichita, KS 67277-2328  
U.S.A.  
Phone: 1-316-942-7411 • FAX: 1-316-942-2012  
Website: [www.rides.com](http://www.rides.com)  
E-mail: [rides@rides.com](mailto:rides@rides.com)

Bulletin No:	B402CRM112-0
Release Date:	December 20, 2002
Effective Date:	Immediately
Supersedes:	N/A
Completion Date:	March 20, 2003
Page:	1 of 3

# SERVICE BULLETIN

Ride Manufacturer: CHANCE RIDES, INC.

Affected Production Dates: All

Ride Name: WIPEOUT

Affected Serial Nos.: All Units

Model No.: 402

**Abstract of Issue:**

Seat Closeout Kit

**Reason For Release:**

Chance Rides Manufacturing, Inc. has become aware that on the WIPEOUT amusement ride, it is possible for a passenger to extend his/her foot outside the seat. If this happens while the ride is in operation, serious personal injury to the passenger can result.

A seat closeout kit has been developed to help restrain the passengers' feet inside the seat.

**Action to be Taken:**

Chance Rides Manufacturing, Inc. requires that all owner/operators of the above noted WIPEOUT amusement rides install the seat closeout kit within 90 days of the release date of this bulletin. Complete installation instructions are provided on the following pages of this bulletin.

Order and install the Seat Closeout Kit, (part number K402R1264-0). The kit will be offered at a reduced price if ordered within 90 days of the release date of this bulletin.

All work must be performed by qualified personnel, capable of understanding the function of the parts and their proper installation. Use only those components authorized, specified or provided by Chance Rides Manufacturing, Inc. All applicable OSHA safety standards and safe industry practices must be observed.

Observe all safety information contained in the manufacturer's manuals. Make available this bulletin and all related technical information to personnel using the equipment.

Chance Rides Manufacturing, Inc. issues notifications for the benefit of owners of amusement rides manufactured by Chance Rides Manufacturing, Inc. As a service to the industry, and in the interest of employee and public safety, Chance Rides Manufacturing, Inc. also issues notifications for the benefit of owners of amusement ride equipment for which the manufacturer no longer exists, such as the Allan Herschell Company, Chance Manufacturing Co., Inc., Chance Rides, Inc., etc. In doing so, Chance Rides Manufacturing, Inc. does not assume liability for losses associated with amusement ride equipment built by manufacturers other than Chance Rides Manufacturing, Inc.





**CHANCE RIDES MANUFACTURING, INC.**  
 4200 Walker  
 Wichita, KS 67277-2328  
 U.S.A.  
 Phone: 1-316-942-7411 • FAX: 1-316-942-2012  
 Website: [www.rides.com](http://www.rides.com)  
 E-mail: [rides@rides.com](mailto:rides@rides.com)

Bulletin No: B402CRM112-0  
 Release Date: December 20, 2002  
 Effective Date: Immediately  
 Supersedes: N/A  
 Completion Date: March 20, 2003  
 Page: 2 of 3

Ride Manufacturer: CHANCE RIDES, INC. Affected Production Dates: All

Ride Name: WIPEOUT Affected Serial Nos.: All Units

Model No.: 402

Detail of Issue

**The SEAT CLOSEOUT KIT (part number K402R1264-0) contains the following:**

<u>Part Number</u>	<u>Component</u>	<u>Quantity</u>
402-115-011	SEAT CLOSEOUT - Left Hand .....	10
402-115-013	SEAT CLOSEOUT - Right Hand .....	10
402-115-012	BACKING BAR .....	20
661500000	RIVET - 3/16 x 3/4 Aluminum Dome .....	200

**Installation Instructions**

1. Locate each seat closeout in position on the seat. If necessary, trim the seat closeouts as required to fit.

*NOTE: The seat closeouts are provided as right-hand and left-hand parts.*

2. Using the backing bar as a template, drill four 0.219 inch diameter holes in the flange of the closeout to match the backing bar as shown.

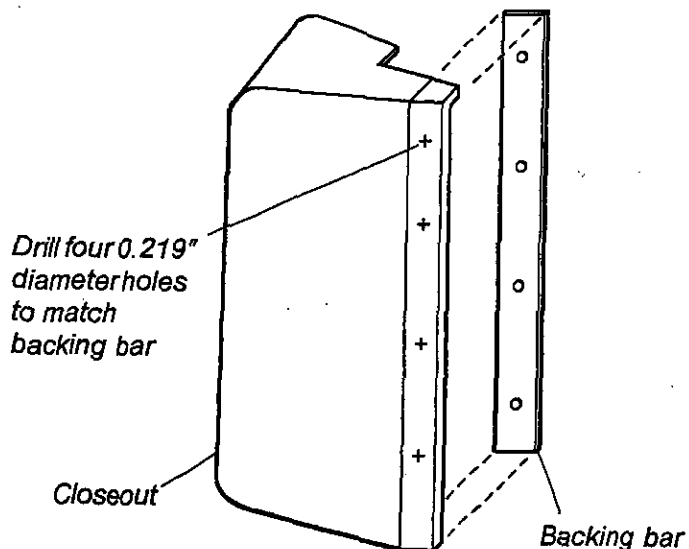



**CHANCE RIDES MANUFACTURING, INC.**  
4200 Walker  
Wichita, KS 67277-2328  
U.S.A.  
Phone: 1-316-942-7411 • FAX: 1-316-942-2012  
Website: [www.rides.com](http://www.rides.com)  
E-mail: [rides@rides.com](mailto:rides@rides.com)

Bulletin No:	B402CRM112-0
Release Date:	December 20, 2002
Effective Date:	Immediately
Supersedes:	N/A
Completion Date:	March 20, 2003
Page:	3 of 3

Ride Manufacturer: CHANCE RIDES, INC.

Affected Production Dates: All

Ride Name: WIPEOUT

Affected Serial Nos.: All Units

Model No.: 402

Detail of Issue (continued):

3. Locate the closeout in position and use it as a template to locate and drill four 0.219 inch diameter holes in the seat. Also, drill six additional holes along the opposite side of the closeout as shown, going through the seat.
4. Insert the backing bar into the seat from the bottom side, aligning the holes in it with the holes in the seat and the closeout.
5. Use the rivets provided to attach the closeout to the seat at 10 places.
6. Repeat the procedure to install all 20 closeouts.

*Drill six 0.219" diameter holes  
through closeout and seat*

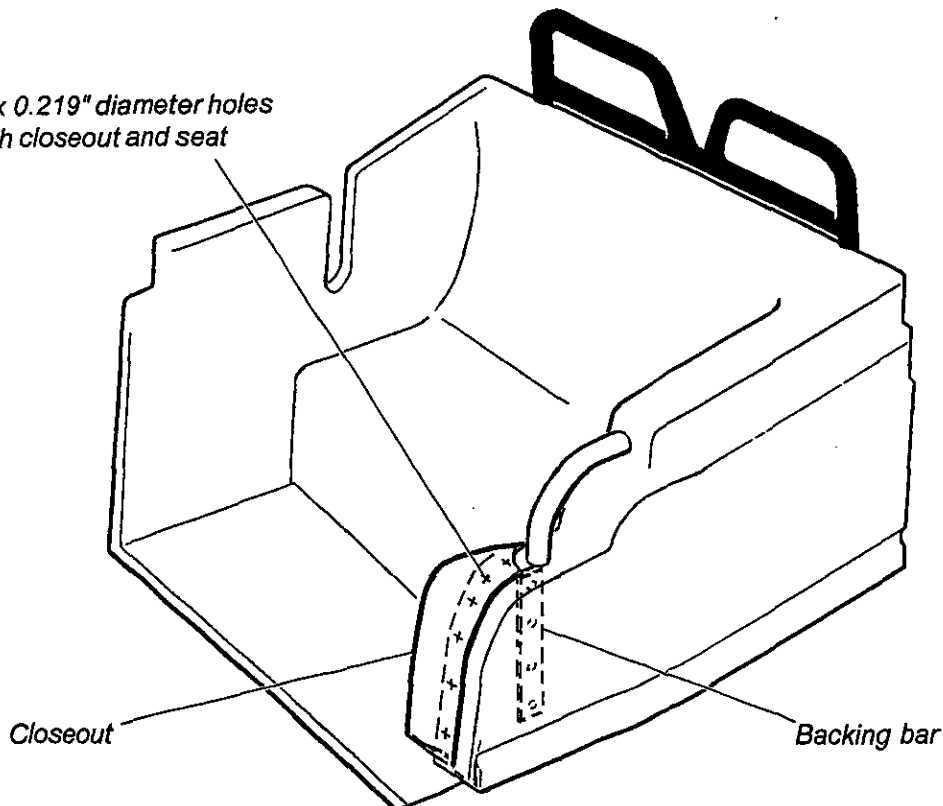



**CHANCE RIDES MANUFACTURING, INC.**  
4200 Walker  
Wichita, KS 67277-2328  
U.S.A.  
Phone: 1-316-942-7411 • FAX: 1-316-942-2012  
Website: [www.rides.com](http://www.rides.com)  
E-mail: [rides@rides.com](mailto:rides@rides.com)

Bulletin No: B402CRM152-0  
Release Date: May 12, 2007  
Effective Date: May 12, 2007  
Supersedes: B402R1109-0  
(Chance Rides, Inc., 1/17/92)  
Completion Date: See Text  
Page: 1 of 4

# SERVICE BULLETIN

Ride Manufacturer: CHANCE RIDES, INC.

Affected Production Dates: All

Ride Name: WIPEOUT

Affected Serial Nos.: All Units

Model No.: 402

**Abstract of Issue:**

Hub Capscrew Torque Check

**Reason For Release:**

This bulletin supersedes Chance Rides, Inc. Service Bulletin B408R1109-0. This bulletin updates and supplements the information contained in B408R1109-0.

The center hub section on the WIPEOUT amusement ride is secured to the bearing with 28 Grade 8 hex head capscrews. It is essential for the care of the equipment and safety of the passengers that the correct length capscrews are installed and that the correct torque is maintained on these capscrews.

This bulletin is being released due to changes in the bearing by its manufacturer. As a result, the correct length of the capscrews varies depending upon the bearing which is installed in that specific ride.

**Action to be Taken:**

Chance Rides, Inc. requires all owner/operators of the above noted amusement rides to immediately perform the inspection described in the bulletin to verify the proper torque of the capscrews. Thereafter, the capscrews must be checked for correct torque at least once per month during the operating season.

As with any ride, perform a daily visual check for signs of loose, broken or missing parts.

All work must be performed by qualified personnel, capable of understanding the function of the parts and their proper installation. Use only those components authorized, specified or provided by Chance Rides Manufacturing, Inc. All applicable OSHA safety standards and safe industry practices must be observed.

Observe all safety information contained in the manufacturer's manuals. Make available this bulletin and all related technical information to personnel using the equipment.

Chance Rides Manufacturing, Inc. issues notifications for the benefit of owners of amusement rides manufactured by Chance Rides Manufacturing, Inc. As a service to the industry, and in the interest of employee and public safety, Chance Rides Manufacturing, Inc. also issues notifications for the benefit of owners of amusement ride equipment for which the manufacturer no longer exists, such as the Allan Herschell Company, Chance Manufacturing Co., Inc., Chance Rides, Inc., etc. In doing so, Chance Rides Manufacturing, Inc. does not assume liability for losses associated with amusement ride equipment built by manufacturers other than Chance Rides Manufacturing, Inc.



**CHANCE RIDES MANUFACTURING, INC.**  
4200 Walker  
Wichita, KS 67277-2328  
U.S.A.  
Phone: 1-316-942-7411 • FAX: 1-316-942-2012  
Website: [www.rides.com](http://www.rides.com)  
E-mail: [rides@rides.com](mailto:rides@rides.com)

Bulletin No:	B402CRM152-0
Release Date:	May 12, 2007
Effective Date:	May 12, 2007
Supersedes:	B402R1109-0 (Chance Rides, Inc., 1/17/92)
Completion Date:	See Text
Page:	2 of 4

Ride Manufacturer: CHANCE RIDES, INC.

Affected Production Dates: All

Ride Name: WIPEOUT

Affected Serial Nos.: All Units

Model No.: 402

Detail of Issue

**Monthly Check of Capscrew Torque**

Using a torque wrench, check for proper torque of all 28 capscrews. The torque value for checking these capscrews must be 80 ft-lbs.

**IMPORTANT:** ALL 28 CAPSCREWS MUST BE TIGHTENED AND MAINTAINED AS DESCRIBED TO OPERATE THE RIDE. If damage in the tapped holes prevents one or more capscrews from meeting these specifications, the bearing must be replaced. Contact the Chance Customer Service Department for all necessary parts and instructions on this procedure.

If any capscrew is found to be loose, remove it and replace it with a new capscrew using the procedure described on page 4 of this bulletin. If a broken capscrew is found, contact Chance Rides, Inc. immediately for further instructions.

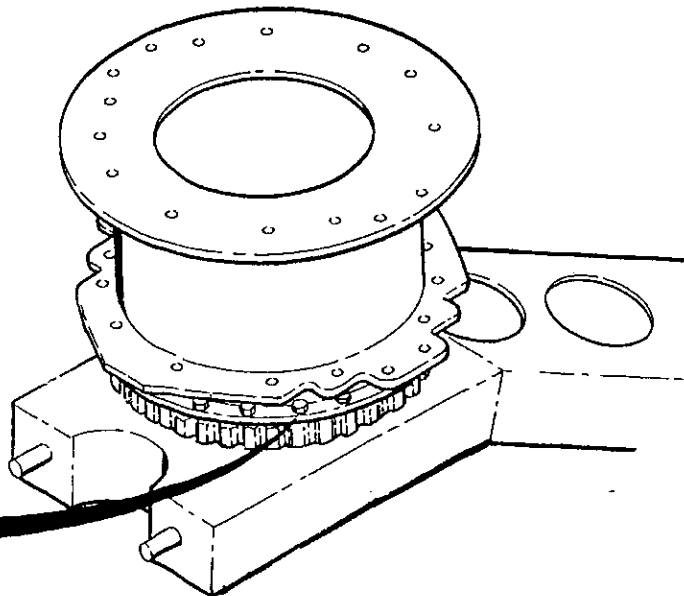

See details  
of this area on the  
following page



**CHANCE RIDES MANUFACTURING, INC.**  
4200 Walker  
Wichita, KS 67277-2328  
U.S.A.  
Phone: 1-316-942-7411 • FAX: 1-316-942-2012  
Website: [www.rides.com](http://www.rides.com)  
E-mail: [rides@rides.com](mailto:rides@rides.com)

Bulletin No:	B402CRM152-0
Release Date:	May 12, 2007
Effective Date:	May 12, 2007
Supersedes:	B402R1109-0 (Chance Rides, Inc., 1/17/92)
Completion Date:	See Text
Page:	3 of 4

Ride Manufacturer: CHANCE RIDES, INC.

Affected Production Dates: All

Ride Name: WIPEOUT

Affected Serial Nos.: All Units

Model No.: 402

Detail of Issue (continued):

#### Determining the Correct Capscrew Length

The correct capscrew length is determined by the tapped holes in the bearing. If any of the capscrews are replaced, use the following illustrations to inspect the tapped holes in the bearing to determine the correct length of capscrew for that specific ride.

**1/2-13 x 1-1/2" long Grade 8 Hex Head Capscrew (part number 60849200)**  
80 ft-lbs torque (monthly check).  
90 ft-lbs torque (initial installation with Loctite® 271)

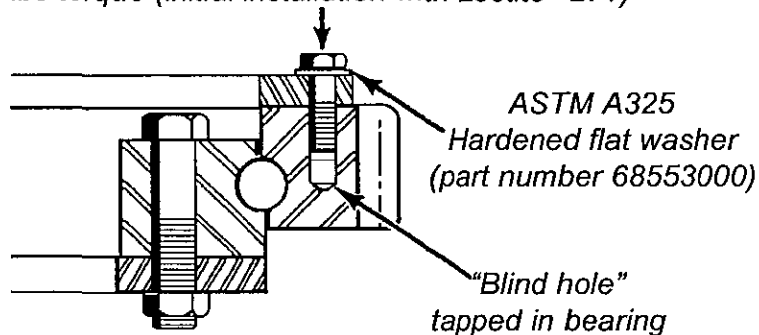

**1/2-13 x 2-1/2" long Grade 8 Hex Head Capscrew (part number 60850100)**  
80 ft-lbs torque (monthly check).  
90 ft-lbs torque (initial installation with Loctite® 271)

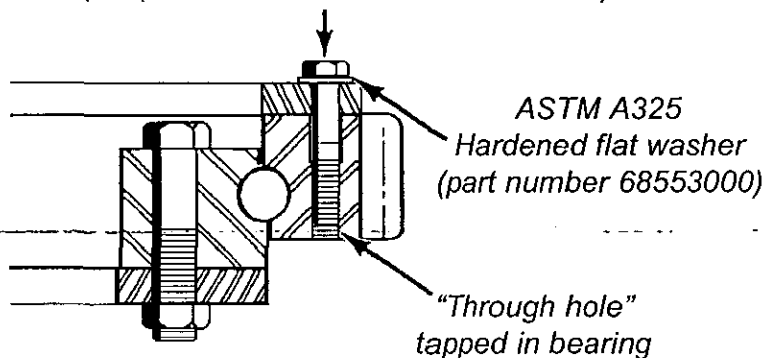



**CHANCE RIDES MANUFACTURING, INC.**  
4200 Walker  
Wichita, KS 67277-2328  
U.S.A.  
Phone: 1-316-942-7411 • FAX: 1-316-942-2012  
Website: [www.rides.com](http://www.rides.com)  
E-mail: [rides@rides.com](mailto:rides@rides.com)

Bulletin No:	B402CRM152-0
Release Date:	May 12, 2007
Effective Date:	May 12, 2007
Supersedes:	B402R1109-0
	(Chance Rides, Inc., 1/17/92)
Completion Date:	See Text
Page:	4 of 4

Ride Manufacturer: CHANCE RIDES, INC. Affected Production Dates: All

Ride Name: WIPEOUT Affected Serial Nos.: All Units

Model No.: 402

Detail of Issue (continued):

**Capscrew Replacement Procedure**

If any capscrew requires replacement, clean and prepare the tapped hole in the bearing using the following procedure.

**IMPORTANT:** *If more than one capscrew is being replaced, remove and replace them one at a time. The existing capscrew and hardened flat washer must be discarded and replaced with new parts of the correct size.*

1. Remove the existing capscrew and hardened flat washer and discard.
2. Using a 1/2-13 UNC bottoming tap, chase the entire length of the threads in the bearing to restore and clean the threads.
3. Using appropriate eye protection, clear chips and other debris from the tapped hole with compressed air.
4. Install the new capscrew with new hardened flat washer under the head, using Loctite® 271 (red).
5. Tighten the capscrew to 90 ft-lbs.