



Issuing Entity:  
Larson International Inc.  
P.O. Box 638  
Plainview, TX 79073-0638  
U.S.A.  
Phone 806-293-1353  
Fax 806-293-5215  
www.larsonintl.com

Bulletin No.: L03-004  
Release Date: 02/24/03  
Effective Date: Immediately

Supersedes: N/A  
Completion Date: N/A

Page: 1 of 1

# SERVICE BULLETIN

Ride Manufacturer: Larson International Inc.    Affected Production Dates: All

Ride Name: Fire Ball    Affected Serial Nos.: All units

Abstract Of Issue:

Clarification of rider restrictions

Reason for Release:

Larson International Inc. has learned that some operators are not following proper guidelines for rider restrictions. This Bulletin is intended to clarify those issues.

Action To Be Taken:

Larson International Inc. requires all owner/operators of the above-named rides to enforce the following rider restrictions:

1. Each rider is to be at least 48" tall.
2. Patrons must be of the height, weight, and shape to properly fit in the passenger seats. The restraint system, including harness and seat belt, must properly and fully engage.
3. The patrons must have sufficient body strength and shoulders in order to maintain themselves in an upright position for the restraints to properly engage the patron and thighs capable of retaining the patron in the seat.



Issuing Entity:  
Larson International Inc.  
P.O. Box 638  
Plainview, TX 79073-0638  
U.S.A.  
Phone 806-293-1353  
Fax 806-293-5215  
www.larsonintl.com

Bulletin No.: L03-006  
Release Date: 7/5/06  
Effective Date: Immediately  
Supercedes: N/A  
Completion Date: N/A  
Page: 1 of 5

# SERVICE BULLETIN

<u>Ride Manufacturer: Larson International Inc.</u>	<u>Affected Production Dates:</u>	<u>All</u>
<u>Ride Name: Fireball &amp; Ring of Fire with Fireball train</u>	<u>Affected</u>	<u>Serial Nos.:</u>
88PA30043	01PT70088	NJ# 03937
89PA50049	01PT70089	
90PA50053	01PT70090	
91PA60056	01PT70091	
92PA60059	02PT70092	NJ# 04466
95PA60074	02PT70093	
99PA60081	02PT70094	NJ# 04380
99PA70082	03PT70095	
99PT70083	03PT70096	
00PT70084	03PT70097	
00PT70085	04PT70098	
00PT70086	04PT70099	
00PT70087	05PT700100	

**Abstract Of Issue:**  
Restraint Bumper Installation

**Reason for Release:**

Larson International Inc. has learned that some parts of the Fireball over the shoulder ratchet assemblies on the passenger vehicles are being bent and or damaged causing safety concerns for the ride. The damage occurs when the restraint is "slammed" shut on an unoccupied seat. There is reasonable concern that this damage could result in a restraint failure.

**Action To Be Taken:**

Larson International Inc. requires all owner/operators of the above-named rides to remove, install and inspect the parts listed on the following pages.

1. Remove all head pad covers.

Larson International Inc. issues notifications for the benefit of owners of amusement rides manufactured by Larson International, Inc. As a service to the industry, and in the interest of employee and public safety, Larson International, Inc. also issues notifications for the benefit of owners of amusement ride equipment for which the manufacturer no longer exists such as LMC, Inc. and Hi-Roller Company. In doing so, Larson International, Inc. does not assume liability for losses associated with amusement ride equipment built by manufacturers other than Larson International, Inc.

2. Remove stop set screw and locknut from upper portion of ratchet assembly.
  3. Add bumper assembly under over the shoulder restraint and weld in place. (see instructions)
  4. Welding must be completed by AWS D1.1 certified welder.
  5. N.D.T inspection of bar at the point where the stop set screw was located is required.
  6. If upon inspection there are signs of bending and or cracking replacing the ratchet bar is necessary.
  7. A copy of the inspection report must be sent to Larson Intl, Inc.
  8. This modification must be completed no later than July 21, 2006. If modifications & N.D.T. are not complete by this date the ride must be taken out of service until testing & modifications are complete
- 

**Note:**

- A:** Check all pins, cotter pins and lubricate ratchet assembly when performing the above mentioned items.
- B:** Larson Intl. suggests the parts for this modification are purchased, including angle bracket mount and rubber stop from the factory for \$445. If you wish to produce these components from scratch Larson Intl. will supply fabrication detail and rubber stop size and durometer.
- C:** The ratchet bar does not have to be removed from housing during the N.D.T. or lubrication process. If ratchet bar is removed from the housing the same ratchet bar must be placed back in the same housing it was removed from as they are all matched sets.

Larson International Inc. issues notifications for the benefit of owners of amusement rides manufactured by Larson International, Inc. As a service to the industry, and in the interest of employee and public safety, Larson International, Inc. also issues notifications for the benefit of owners of amusement ride equipment for which the manufacturer no longer exists such as LMC, Inc. and Hi-Roller Company. In doing so, Larson International, Inc. does not assume liability for losses associated with amusement ride equipment built by manufacturers other than Larson International, Inc.

Larson International Inc. issues notifications for the benefit of owners of amusement rides manufactured by Larson International, Inc. As a service to the industry, and in the interest of employee and public safety, Larson International, Inc. also issues notifications for the benefit of owners of amusement ride equipment for which the manufacturer no longer exists such as LMC, Inc. and Hi-Roller Company. In doing so, Larson International, Inc. does not assume liability for losses associated with amusement ride equipment built by manufacturers other than Larson International, Inc.

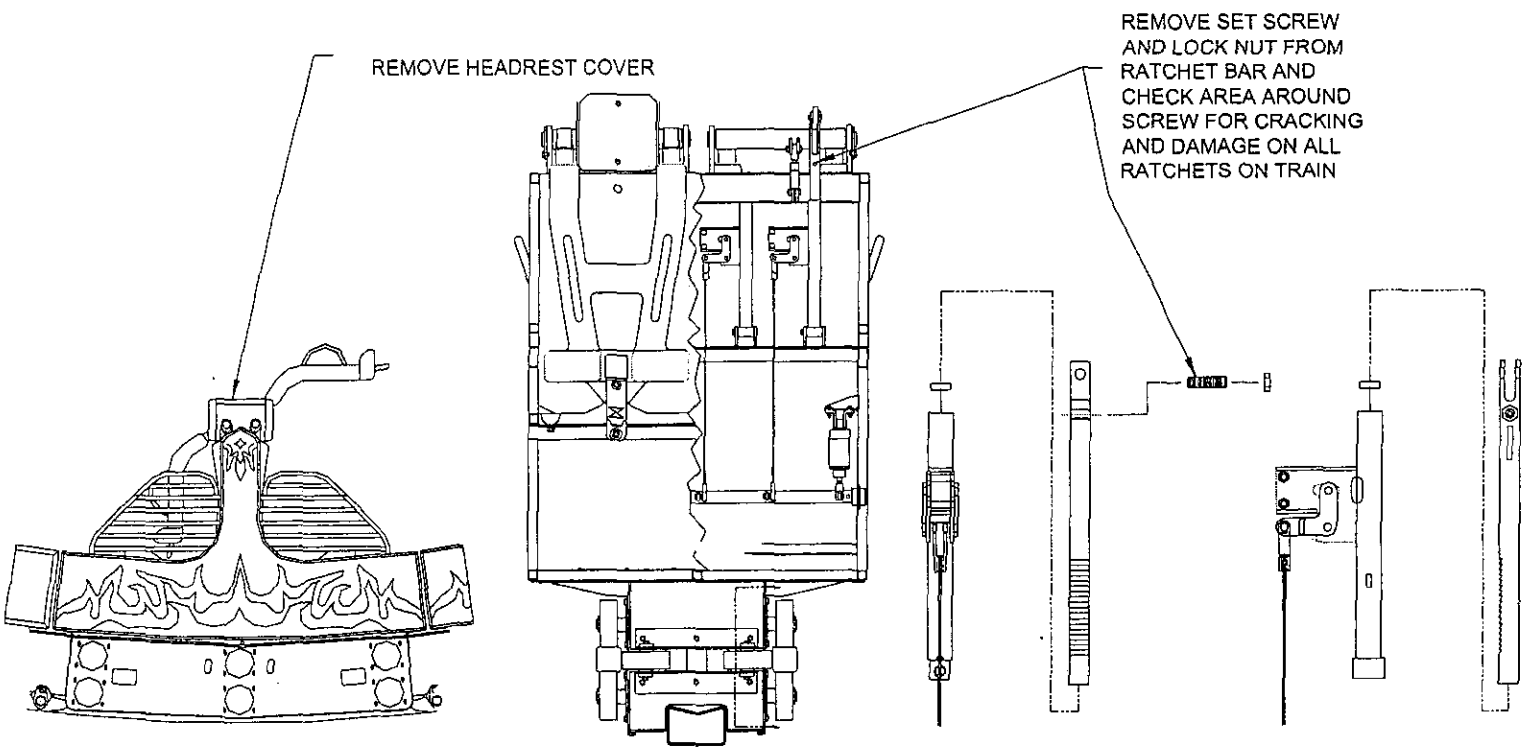

Larson International Inc. issues notifications for the benefit of owners of amusement rides manufactured by Larson International, Inc. As a service to the industry, and in the interest of employee and public safety, Larson International, Inc. also issues notifications for the benefit of owners of amusement ride equipment for which the manufacturer no longer exists such as LMC, Inc. and Hi-Roller Company. In doing so, Larson International, Inc. does not assume liability for losses associated with amusement ride equipment built by manufacturers other than Larson International, Inc.

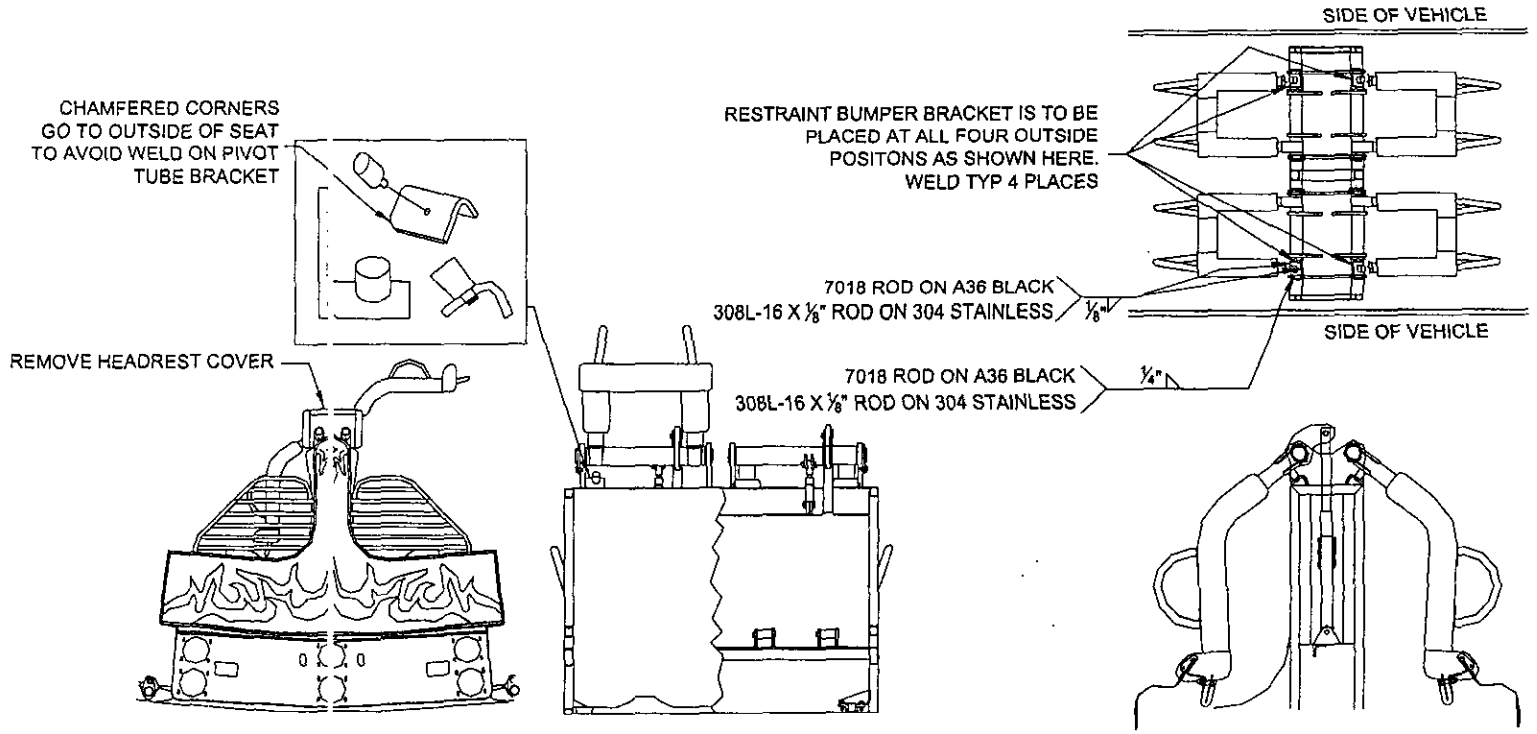

NOTE: ALL TRAINS ARE 304 STAINLESS STEEL EXCEPT:  
99PA60081  
99PA60082  
99PA60083

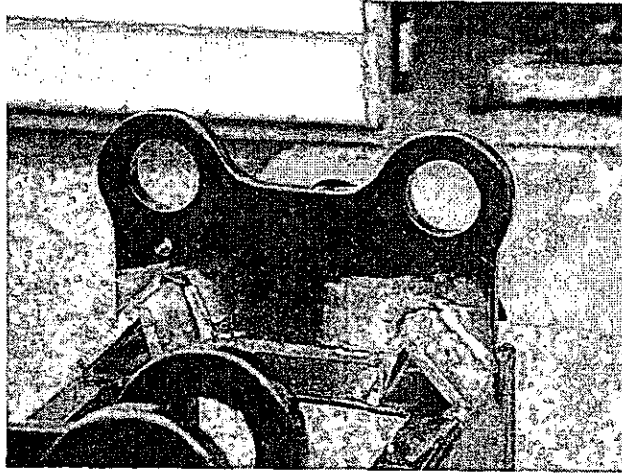

Mount brackets flush with channel.

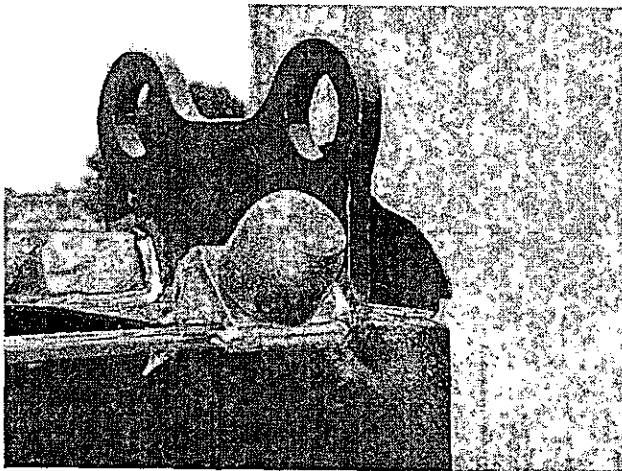
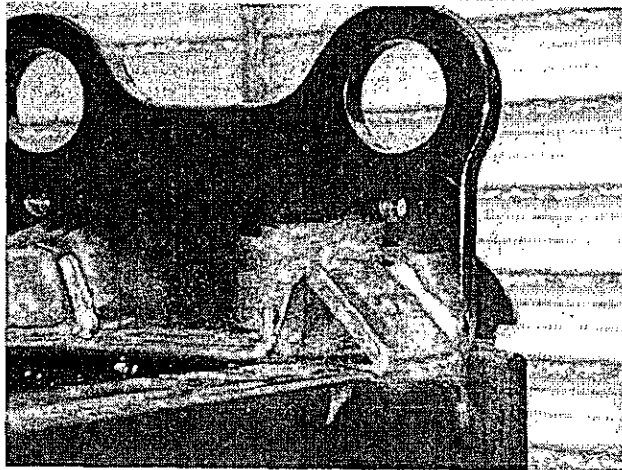

After weldment and painting are complete screw in rubber bumper as shown.

Larson International Inc. issues notifications for the benefit of owners of amusement rides manufactured by Larson International, Inc. As a service to the industry, and in the interest of employee and public safety, Larson International, Inc. also issues notifications for the benefit of owners of amusement ride equipment for which the manufacturer no longer exists such as LMC, Inc. and Hi-Roller Company. In doing so, Larson International, Inc. does not assume liability for losses associated with amusement ride equipment built by manufacturers other than Larson International, Inc.