



WISDOM INDUSTRIES, INC.



# REQUIRED INSPECTION NOTICE

**DATE:** JULY 31, 1998  
**RIDE:** CLATTERPILLAR  
**SUBJECT:** ROD END COUPLER THREADS  
**REQUIRED COMPLIANCE:** MANDATORY  
**COMPLETION DATE:** IMMEDIATELY

One coaster has experienced wear on the threads on the rod end connecting the cars together. The wear is caused by the lock nut loosening and allowing the rod end to work back and forth in the coupler mount. To prevent the possibility of the rod end pulling out of the mount, check the threads in all rod end couplers for wear and replace any that are worn.

## **TO INSPECT FOR THREAD WEAR**

1. Loosen jam nut on rod end.
2. Raise and lower the front of the car that the rod end is attached to.
3. Look for looseness or movement of the thread end inside the coupling mount as the front of the car is raised and lowered.
4. If no looseness is observed retighten the rod end.
5. If the threads are loose remove the rod end and replace.
6. Retighten the rod end.

## **REPLACING THE ROD END**

1. Block up front of car.
2. Remove 1 inch connecting bolt.
3. Disconnect safety chain.
4. Push car ahead to allow access to rod end.
5. Loosen lock nut.
6. Unscrew rod end from coupler.
7. Screw lock nut from original rod end onto new rod end.

8. Check for looseness in the coupler by moving the rod end up and down.
9. If it is still loose the coupler may need to be replaced.
10. Tighten lock nut.
11. Reconnect cars together with 1 inch bolt and lock nut.
12. Connect safety chain.
13. Check that the lock nut is tight.
14. Remove blocks and check track for objects that will stop the train.
15. Test run ride.
16. Check that the jam nut is tight daily.

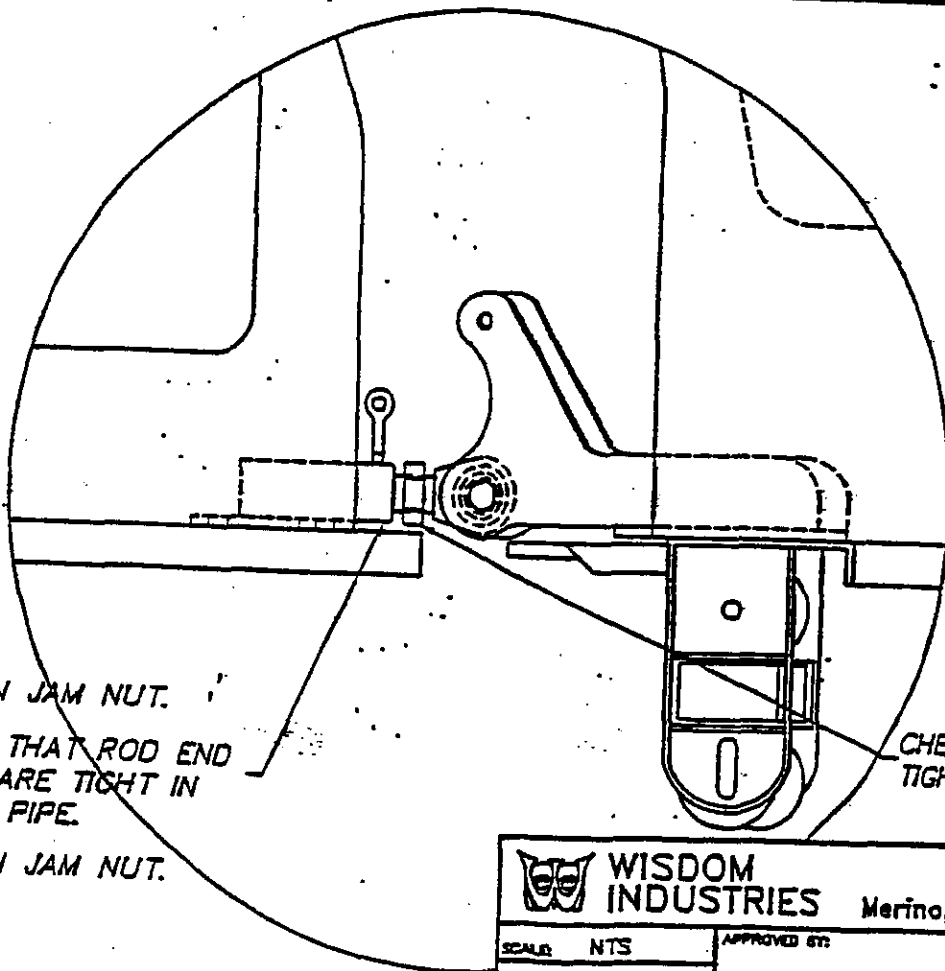

1. LOOSEN JAM NUT.
2. CHECK THAT ROD END THREADS ARE TIGHT IN MOUNTING PIPE.
3. TIGHTEN JAM NUT.

CHECK JAM NUT FOR TIGHTNESS DAILY.

 <b>WISDOM INDUSTRIES</b> Merino, CO 80741		
SCALE: NTS	APPROVED BY:	DRAWN BY: J.C.
DATE: 7-19-96		REVISED:
DESCRIPTION CAR HITCH		
EQUIPMENT: COASTERS		DRAWING NUMBER DWG #



WISDOM INDUSTRIES, INC.



# REQUIRED INSPECTION NOTICE

**DATE:** JULY 31, 1998  
**RIDE:** CLATTERPILLAR  
**SUBJECT:** ROD END COUPLER GREASE ZERK HOLES  
**COMPLIANCE:** MANDATORY  
**COMPLETION DATE:** IMMEDIATELY

One coaster has has one rod end crack at the grease zerk hole. Inspect the rod end, between the cars for cracking in the grease zerk area.

## **TO INSPECT FOR CRACKS.**

1. Thoroughly clean the area around the grease zerk.
2. Inspect the area around the ground zerk for cracks.
3. If there is a question about cracking use a dye penetrant kit to check for cracks.
4. If no cracks are found include a check of the grease zerk area in the daily inspection of the ride.
5. If the rod end is cracked replace the rod end.

## **REPLACING THE ROD END**

1. Block up front of car that the rod end is going to be replaced on.
2. Remove 1 inch connecting bolt.
3. Disconnect safety chain.
4. Push car ahead to allow access to rod end.
5. Loosen lock nut.
6. Unscrew rod end from coupler.
7. Screw lock nut from original rod end onto new rod end.
8. Screw in new rod end.

**NOTE:** The threads must be screwed in at least 1 to 1.25 inches into the coupler.

9. Screw new rod end into coupler.
10. Tighten lock nut.
11. Reconnect cars together with 1 inch bolt and lock nut.
12. Connect safety chain.
13. Check that the lock nut is tight.
14. Remove blocks and check track for objects that will stop the train.
15. Test run ride.
16. Check that the jam nut is tight daily.

CLEAN AREA AROUND ZERK.  
INSPECT FOR CRACKS.  
REPLACE IF CRACKED.

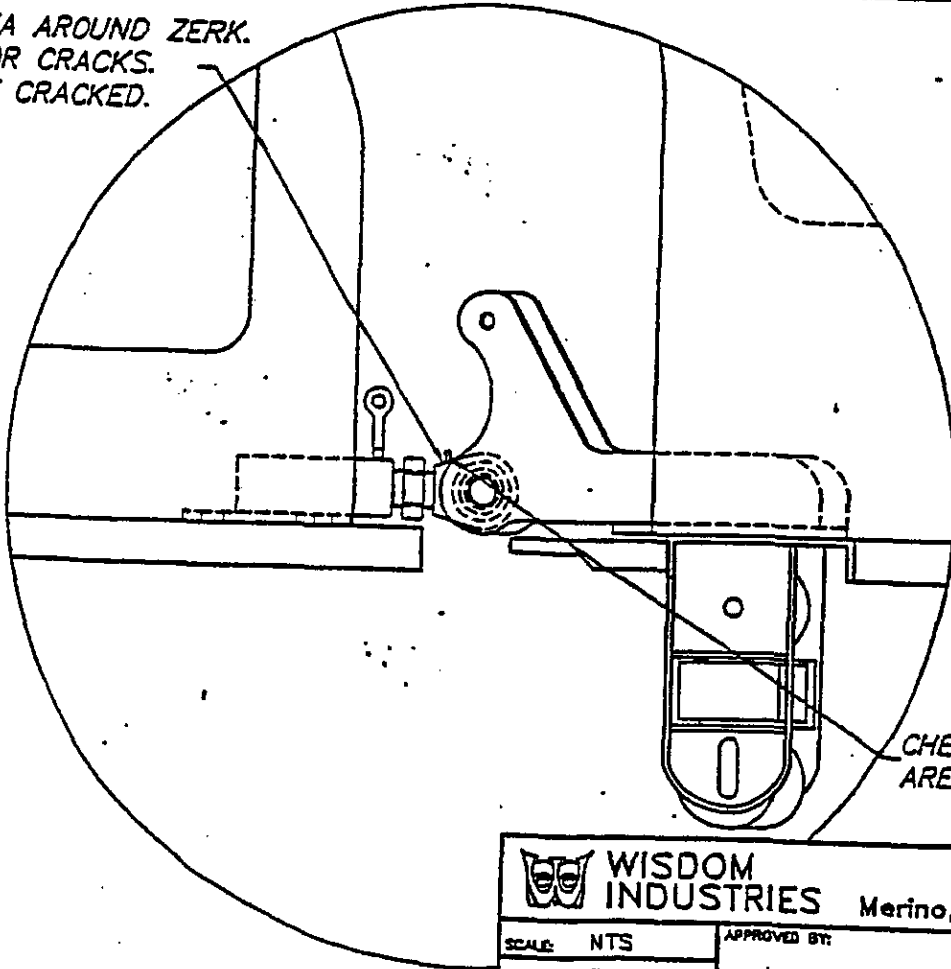

CHECK GREASE ZERK  
AREA FOR CRACKS.

 <b>WISDOM INDUSTRIES</b> Merino, CO 80741		
SCALE: NTS	APPROVED BY:	DRAWN BY: JLC
DATE: 7-19-96		REVISED
DESCRIPTION CAR HITCH		
EQUIPMENT: COASTERS		DRAWING NUMBER DWG #



**WISDOM  
INDUSTRIES, Ltd.**

# **SERVICE BULLETIN**

**DATE: FEB. 10, 2000**

**RIDE: GO GATOR, CLATTERPILLAR, SMALL DRAGON,  
MINER MIKE**

**SUBJECT: COASTER WHEEL BRACKETS**

**COMPLIANCE DATE: IMMEDIATE**

Remove the bottom wheel and inspect the slotted adjustment hole for cracks. If cracks are found, "V" out the crack, weld, and grind smooth. We have available a doubler reinforcement plate for these brackets that may be added. After the doubler plate is installed further inspections are required on an annual basis.

If the plates are not added remove the wheels monthly for inspection.

Contact Wisdom Industries for these plates and installation instructions.

- **WARNING:** When loosening and tightening wheel bolts, either for adjustment or removal, hold the nut and turn the bolt. The nut must be the flanged nut supplied with the ride or similar

If you have any further questions, please call Wisdom Industries.