

ISDOM  
FG. INC.

Box 1794  
Sterling, CO. 80751

Shop: 303/522-7515

Evening: 303/522-0688

2/13/76

## MAINTAINENCE INSTRUCTIONS

1. Lubricate top and bottom spindle bearings once a month with 4 shots of good Moly grease or equivalent. Do not over grease.
2. Middle and bottom center pole bearings should be greased weekly with the same grease.
3. Top guide bearing in the center pole should be greased once a year with 3 shots of the same grease.
4. 2-3 drops of 10W oil on seat lock pins each week or daily when it rains.
5. Check footboard hinge bolts weekly for security and to be sure lock nuts are in place. To do this, remove chrome plug from side of seat (both sides) and look inside or feel inside to be sure nut is in place.
6. Good MS 10W motor oil can be used in the hydraulic tank or hydraulic oil such as Mobil DTE 24.
7. Oil and hydraulic filters should be drained and replaced each year, preferably in the Fall before parking the ride for the Winter. This will keep moisture out of the system.
8. Polish the seats monthly with a good automotive wax.
9. Check oil in 12V pump monthly and add as needed.
10. Check hoses and hydraulic motors for pinholes and seal leaks regularly so they can be stopped before they become messy.

## SIZZLER

1. The ride start button must be a momentary contact type of control. A constant contact switch should not be used or modification of the control, which will allow the operator leave the ride while it, is running.
2. Oil the foot tub hinge bolts weekly. The foot tub hinge bolts can rust into position and cause the hinge bolt to shear off when the foot tub is opened. This is especially important when the ride is stored for the winter.
3. Check each hinge bolt and nut weekly. If the nut is loose do not use the seat until it is replaced with a new lock nut.
4. The foot tub should have at least 4 inches clearance from the bottom of the foot tub to the gooseneck of the trailer when the seat is empty and 2 inches when the seat is loaded with 350 pounds.
5. Check that the seat lock brass is tight and that the seat lock pin engages the brass by  $3/8$  inch. Worn brass should be built up or replaced.
6. Check that seat lock pins move freely in and out. Lubricate weekly.
7. Bolts or extra long set screws should not be used at any time to retain the seat lock pin.
8. Check that seat signs are legible.
9. Check the seat sweeps next to the seat for cracks.
10. Check that the moving sweep safety turnbuckles are snug.
11. Check the cabbage head ears for cracks daily. They should be magnafluxed yearly. The cabbage head ear safety plates are mandatory.
12. The top sweeps should be checked for cracks near the main hinges each week.
13. Check that the drive rims are dry. Oil on the drive rim will keep the ride from stopping properly.
14. If the trailer axle has been flipped out from under the trailer while going down the road the main axle should be checked for cracks.
15. Check around the center pole cutouts for cracks.

16. On all SIZZLERS, the axle is held in front by two clips or pins. The axle should always be fastened going down the road. The axle can flip out from underneath the trailer when the brakes are applied at highway speeds.
17. The trailer hoist should be checked for cracks weekly. Never crawl under the trailer unless it is hooked up to a tractor.

## **SUPER SIZZLER**

◆ **NOTE:** Many of the items listed for the regular SIZZLER are the same for the SUPER SIZZLER. Use the previous page and the following when inspecting the SUPER SIZZLER.

1. Check that the sweep side panels are pinned up and safety keyed.
2. Check the top sweeps for cracks at and near the hinges.
3. Check cabbage head ears each week for cracks where they weld to the cabbage head.
4. Check that both pins are installed and safety keyed on the swing around sweep.
5. The swing around sweeps should be pinned with the pins provided or grade 8 bolts.
6. Foot tub side panels must be installed when operating.
7. Check the seat lock air cylinder for freedom of movement. The air cylinder is air unlock spring lock.
8. Check that the seat back rail is securely fastened and all bolts are installed.
9. Check that the handle bar rod ends are not worn out.
10. Check that the stop chain stops the handle bar before the air shocks reach the end of their stroke. The handle bar should remain up by itself.
11. Check that the seat lock bracket is tight to the side of the car and that all bolts are installed.
12. Check that the three corner platform pieces are pinned and safety keyed.



# WISDOM MANUFACTURING, INC

## SIZZLER BULLETIN

**DATE:** JUNE 1982  
**TO:** ALL SIZZLER OWNERS  
**SUBJECT:** SIZZLER MAIN CENTER POLE SHAFT-NDT

It has been determined that any time the rear of the trailer has been dropped by the axle flipping out from underneath it, there is a possibility that the main center pole shaft has been cracked. The ride must be removed from the main center pole shaft and the center pole shaft magnaflexed for cracks.

- Step 1 Set up the ride.
- Step 2 Turn off power to the ride.
- Step 3 Remove the commutator brush and ring assembly.
- Step 3 Remove the double nut center pole adjustment arrangement.
- Step 4 Lift the ride with a crane from the center pole shaft.
- Step 5 Magnaflex the center pole shaft at the base where the lower bearing support ring is located.
- Step 6 Magnaflex the center pole gussets where they are welded into the trailer for cracks.

**If the center pole is cracked, replacement of the entire pole is required.**

**If there are cracks found in the center pole gusset, they can be rewelded.**

- Step 7 It is recommended to inspect the lower main Sizzler bearing for wear, erosion or rust-pitting and replace if necessary prior to reassembly of the ride.
- Step 8 Reassemble the ride.

For a more detailed instruction on how to disassemble the SIZZLER, contact Wisdom Manufacturing for instructions.

# WISDOM FG. INC.

June 3, 1985

Dear [REDACTED]

Since 1972 there have been two incidents of cabbage head ears breaking off. We now have available a CABBAGE HEAD EAR SAFETY PLATE kit. Enclosed is a sketch that shows how the safety plates are installed on the cabbage heads. We feel that the installation of these plates will help to eliminate this potential for serious accidents. These plates are a safety only and do not in anyway replace the cabbage head ears and the daily inspection of these ears. The safety plate kit can be installed after the ride is setup.

According to our records, the seat sweep safety turnbuckles have not been installed on all Sizzlers. The turnbuckles eliminate the slack in the moveable seat sweeps while the ride is running. Even though, the set screws installed on all Sizzlers will also eliminate the slack, we have found that few operators keep them adjusted. If the movable seat sweeps are allowed to keep pounding on the channel, that the set screws are mounted into, the channel will eventually will break off. Enclosed is a sketch showing where the safety turnbuckles are mounted. If your Sizzler does not have them or you need replacement turnbuckles contact us and we will send them out to you.

The cost of the cabbage head ear safety plate kit which includes six plates, bolts, and nuts is \$174.20. The cost of the safety turnbuckles and replacement bolts is \$245.70 per set or \$42.45 each. Six turnbuckles are required for each ride.

Both of these items, the cabbage head safety plates and the safety turnbuckles are a necessity on your ride and can be supplied immediately.

If you no longer own Sizzler serial number [REDACTED] please contact us with the new owners name so that we can notify him that these safety kits are available.

If you have any questions about these kits please call and ask for Victor or Jerry.

Sincerely,

*Victor H. Wisdom*  
Victor Wisdom

VLW/nb



# WISDOM MANUFACTURING, INC

## SIZZLER BULLETIN

DATE: JUNE 3, 1985  
TO: ALL SIZZLER OWNERS  
SUBJECT: CABBAGE HEAD EARS

Due to reports of cracks in the cabbage head ears, it is required to annually Nondestructive Test the cabbage head ears for cracks.

### INSPECTION OF THE EARS.

- Step 1 Remove the cabbage head safety plates.
- Step 2 Remove the paint in the area of the weld and contact areas for the magnaflux unit.
- Step 3 Inspect the welds and ears for cracks.
- Step 4 Repaint where the paint was stripped.
- Step 5 Reinstall the cabbage head safety plates.

Any cracking that is discovered in the weld only can be grooved out and rewelded.

Any cracking in the ear requires replacement of the entire ear.

Perform this inspection on an annual basis.

Carrying passengers in a car with a cracked cabbage head ear is not allowed until the ear has been replaced or rewelded according to the above procedure.

Follow accepted procedures for operation of NDT Test equipment and for evaluating results. The above instructions are a guideline only. Consult you local qualified NDT Inspector for proper techniques in testing and reading results.

01-155-01  
REINFORCEMENT STRAP

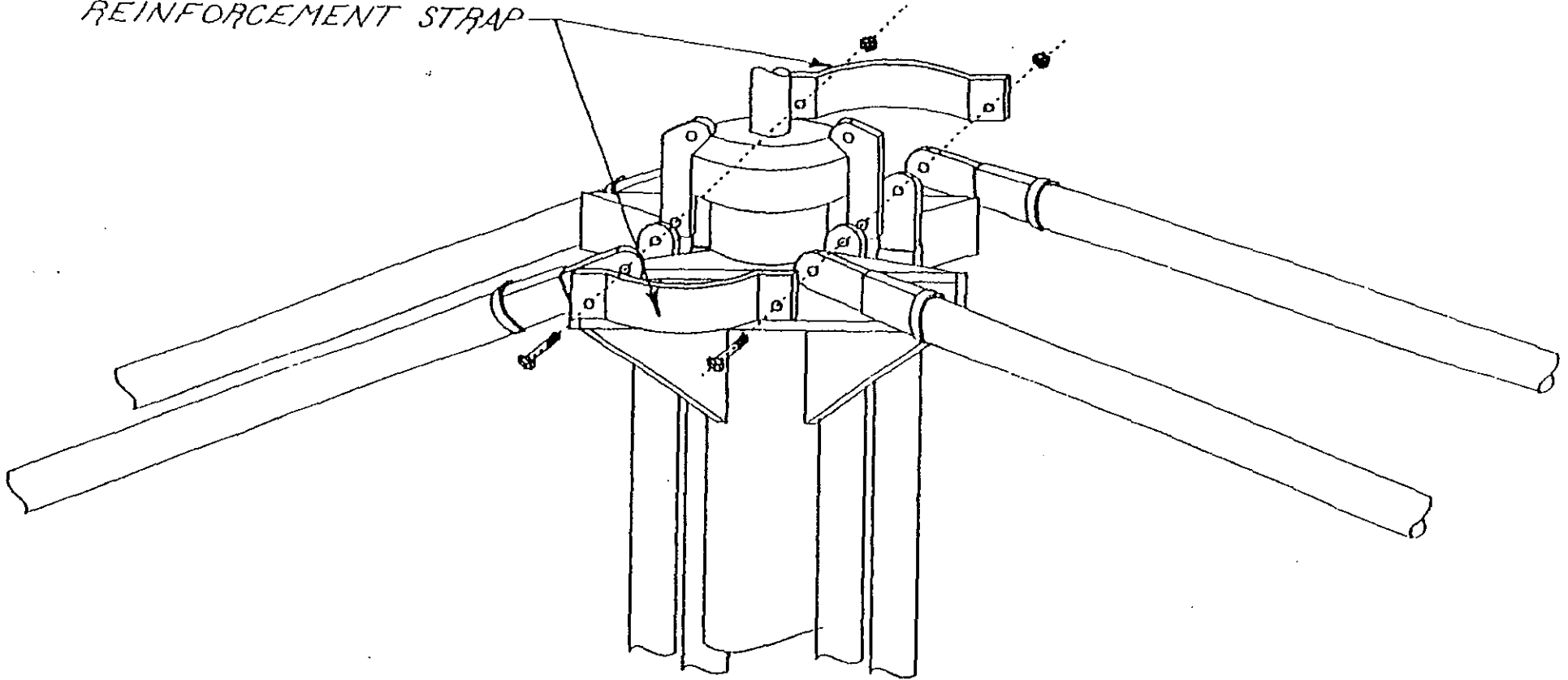

 ISDOM FG. INC. MERINO, CO		
SCALE: NONE	APPROVED BY:	DRAWN BY HATCH
DATE: 5-30-85		REVISED
CABBAGE HEAD REINFORCEMENT STRAP		
SIZZLER	01	DRAWING NUMBER 10



WISDOM INDUSTRIES, INC.



# NOTICE

DATE: JULY 1994  
 RIDE: SIZZLER  
 SUBJECT: CABBAGE HEAD EARS

Magnaflux, ultrasonic or dye penetrant Non-Destructive Testing is required on the Cabbage Head Ears on the SIZZLER. The DELUXE SIZZLER or the SUPER SIZZLER requires a daily visual inspection for cracks of these ears prior to operation.

Refer to the drawing to identify the SIZZLER Cabbage Head style requiring magnaflux, dye penetrant, or ultrasonic testing outlined in the bulletin dated June 3, 1985.

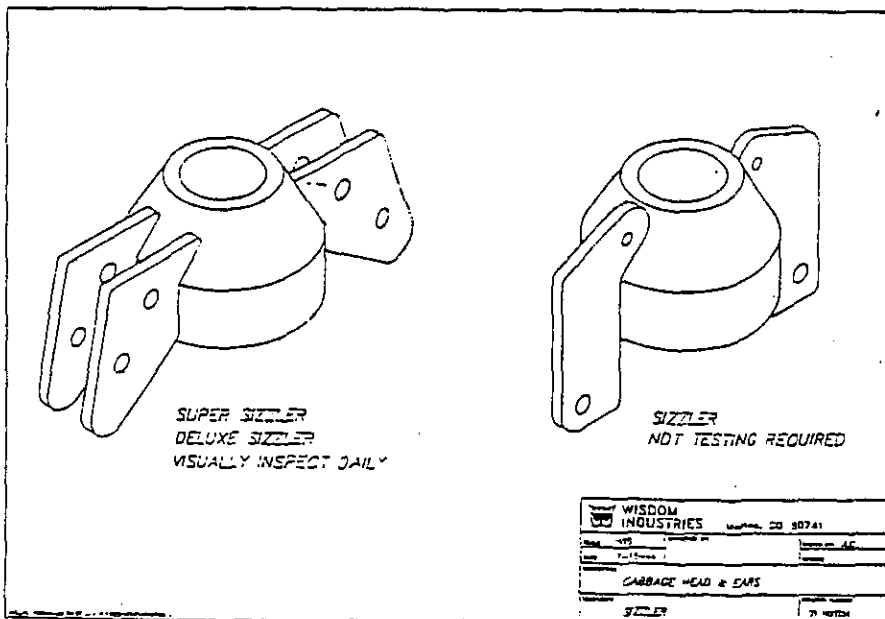



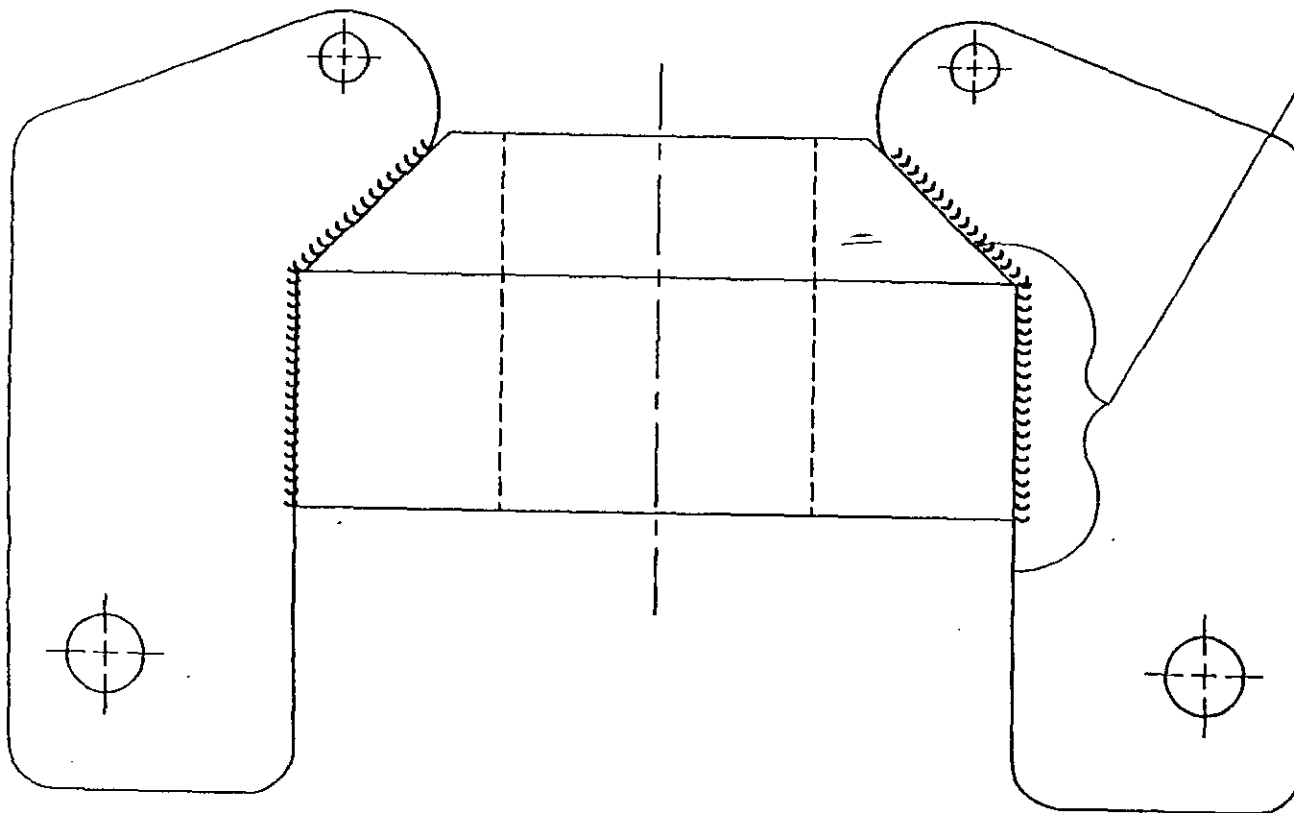

AREA TO MAGNAFLUX  
ANNUALLY FOR CRACKS.  
VISUALLY INSPECT EACH  
WEEK.

 <b>WISDOM INDUSTRIES</b>		Merino, CO 80741	
SCALE: 3"=1'-0"	APPROVED BY:		DRAWN BY: JLC
DATE: 3-3-94			REVISED
DESCRIPTION			
<i>CABBAGE HEAD EAR &amp; CABBAGE HEAD</i>			
EQUIPMENT:		DRAWING NUMBER	
<i>SIZZLER</i>		01 100	



WISDOM INDUSTRIES, INC.



# REQUIRED INSPECTION NOTICE

DATE: AUGUST 1994  
RIDE: SIZZLER  
SUBJECT: INSPECTION OF SEAT MOUNTING BOLTS

It has been determined by Wisdom Industries that the retaining bolts that fasten the internal car frame on the SIZZLER to the spindle sweep must be checked for tightness on a regular basis. If the fasteners become loose the seat can come loose resulting in possible serious injury to the passengers.

The owners of SIZZLER amusement rides are therefore required to inspect their rides as described in this bulletin. Perform the inspection using the instructions on the enclosed page of this bulletin. Return certificate of compliance within 15 days of the receipt of this bulletin. Inspection must be performed within 1 week.

Immediately check seats for looseness by lifting the rear right side corner of the fiberglass body. If any looseness is noticed do not use that seat until the inspection is performed.

If there are any questions regarding the instructions on this inspection, contact Wisdom Industries.

10/2

## THE INSPECTION OF THE SIZZLER RIGHT SIDE SEAT INTERNAL FRAME MOUNTING BOLTS.

### SIZZLERS WITH THE PLASTIC "S" PANEL OR THE FIBERGLASS COVERS OVER THE SEAT UNLOCKING SOLENOIDS.

1. Remove the "S" panel or the fiberglass cover on the right side of the car.
2. Reach down into the seat and check to see that the two mounting bolts in the frame are tight. If the bolts are loose, broken, or missing remove them and reinstall using Loctite to secure the bolts.
3. If you are unable to reach the bolts through the hole, follow the steps: "FOR SIZZLER THAT DO NOT HAVE "S" PANELS."

### FOR SIZZLERS THAT DO NOT HAVE "S" PANELS

1. Remove the two bolts holding the seat lock brass to the side of the car.
2. Slide out the quarter side panel and check the two internal frame mounting bolts for tightness. Replace if they are loose or broken and use Loctite.

## FOR INSPECTION OF THE LEFT SIDE SEAT IRON

1. Remove seat liner OR cut a hole in the left side of the car body using a hole saw. Review the enclosed drawing for the location of the hole. Using a minimum of a 3" hole saw up to 5" diameter.
3. Locate the hole, drill the hole through the fiberglass and inspect the two mounting bolts. If you would like a cover for this hole. Contact us and we will provide inspection covers for these holes.
4. Check the bolts for looseness, missing bolts or sheared bolts and replace with grade 5-7/16" fine thread bolts and Loctite if needed.

Please notify Wisdom Industries following this inspection and notify us to the status of the bolts on your ride. Following this inspection, please return the enclosed compliance sheet. If you have any questions, please contact Wisdom Industries.

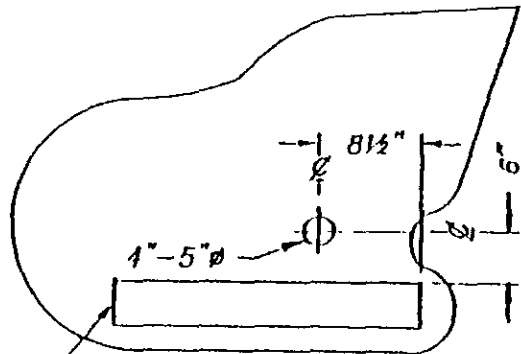

SWEEP CUT OUT

LEFT SIDE OF SEAT

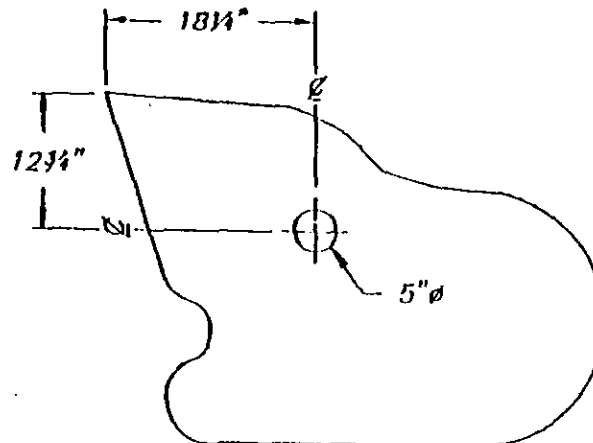

RIGHT SIDE OF SEAT

IF RIGHT SIDE INSPECTION HOLE IS DESIRED.  
 NOTE: 1 LEVEL TRAILER.  
 2 USE LEVEL FROM BACK CORNER OF SEAT  
 TO MARK CENTER LOCATION.

 <b>WISDOM INDUSTRIES</b> Merino, CO 80741		
SCALE: N.1.5	APPROVED BY:	DRAWN BY: MFK
DATE: 08-25-94		REVISED:
DESCRIPTION		
SEAT INSPECTION HOLE LOCATIONS		
EQUIPMENT:		DRAWING NUMBER
SIZZLER		SEAT



**WISDOM  
INDUSTRIES, Ltd.**

August 25, 1994

**SIZZLER SEAT INSPECTION COMPLIANCE NOTICE**

SIZZLER SERIAL NUMBER \_\_\_\_\_

DATE INSPECTED \_\_\_\_\_

OWNER COMPANY NAME \_\_\_\_\_

OWNER ADDRESS \_\_\_\_\_

\_\_\_\_\_  
\_\_\_\_\_

NUMBER OF SEAT FRAME BOLTS LOOSE \_\_\_\_\_

NUMBER OF SEAT FRAME BOLTS BROKEN \_\_\_\_\_

NUMBER OF SEAT FRAME BOLTS MISSING \_\_\_\_\_

We no longer own this ride

The Sizzler was sold to \_\_\_\_\_

Address \_\_\_\_\_

\_\_\_\_\_  
\_\_\_\_\_

INSPECTED BY (Print name) \_\_\_\_\_

SIGNATURE \_\_\_\_\_

Return to: Wisdom Industries  
Box 5000  
Sterling, CO. 80751

151



# WISDOM INDUSTRIES, Ltd.

## SIZZLER BULLETIN

**DATE:** MAY 1997  
**RIDE:** SIZZLER/DELUXE SIZZLER FOOT TUB  
**SUBJECT:** Inspect the pivot hole on each side of each foot tub on the SIZZLER/DELUXE SIZZLER for corrosion and excessive wear  
**COMPLIANCE:** Inspection Daily before operating ride.  
**FREQUENCY:** DAILY

### INSPECTION

1. Inspect the pivot hole on the foot tub for excessive wear. Approximately 1/8th inch maximum play on foot tub next to hinge.
2. Inspect the fiberglass in the hinge area for cracks or fracturing which would indicate the internal steel is broken or worn to the point of relying on the fiberglass for strength. (Hole should be centered on boss on side of fiberglass foot tub).
3. Check clearance of the foot tub to the gooseneck, Minimum 2 inch clearance with a person standing on the step of the foot tub. Measure to the corner of the gooseneck.
4. If foot tub noticeably slopes down, perform inspection before allowing passengers in the seat. Close any seat that does not meet this inspection criteria.

Replacement of the foot tub or foot tub internal steel is required for repair.

### **\*\*WARNING\*\***

**Failure of the foot tub hinge point will result in injury to your passengers.**

Contact Wisdom Industries with any discrepancies on the foot tubs that you find which will require replacement or reinforcement of the foot tub hinge.

If you no longer own this ride, please contact us so we can update our records. Thank you for your cooperation in this matter. If you have any questions about this bulletin, please feel free to contact us at 1-800-634-6097 or 1-970-522-7515.

## SIZZLER

### LAP BAR & SEAT LOCK INSPECTION PROCEDURE

1. Raise lap bar and latch.
2. Check lap bar hinge bolts and pipe for wear or looseness.
3. Check lap bar arm for cracks.
4. Check that seat lock brass is tight.
5. Open lap bar.
6. Push seat lock pin. It must snap back out and not drag or catch.
7. Close lap bar. Seat lock pin must snap into the notch in the brass.  
3/8 inch minimum engagement of pin in brass.

➤ **NOTE: ELECTRIC SEAT UNLOCKING IS NOT MANDATORY.**

8. Activate electric unlocking system.  
**NOTE:** All seat locks should release.
9. Turn off electric unlocking system.  
**NOTE:** The timer will shut off the solenoids after about 15 seconds.
10. Go around seat to inside (spindle side) and pull on the lap bar sideways and out to try to pop seat lock pin out of the brass.
11. If bar comes open, tie off that car until repairs are made. Replace any components needed if the bar will come open.
12. Repeat for each seat.

#### **\*\*WARNING\*\***

Never install a bolt or knob to manually unlock the lapbar. Passengers have been known to open the bar while the ride is running and come out of the seat.

#### **\*\*NOTE\*\***

Each seat lock pin is custom drilled for each car and lap bar. Make sure the same pin goes back to the same bar on the same car.

**INSPECT CLEARANCE OF FOOTTUB TO SWEEP AND TRAILER GOOSENECK.**

**SEE ATTACHED BULLETIN.**

Please notify Wisdom Industries following this inspection and notify us to the status of the bolts on your ride. If you have any questions, please contact Wisdom Industries at 800-634-6097.

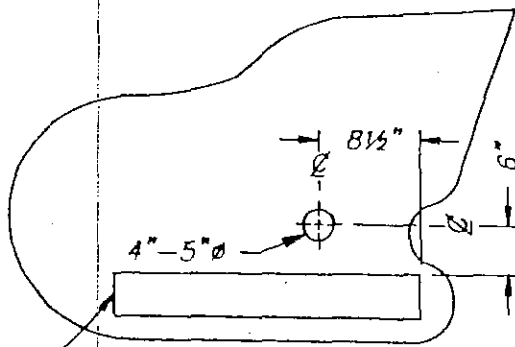

SWEEP CUT OUT

LEFT SIDE OF SEAT

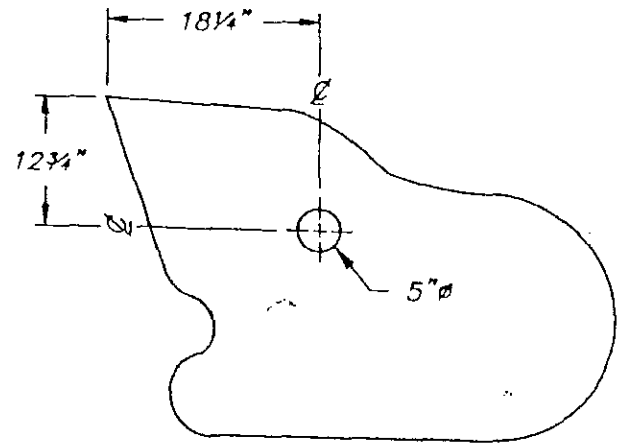

RIGHT SIDE OF SEAT

IF RIGHT SIDE INSPECTION HOLE IS DESIRED.  
 NOTE: 1 LEVEL TRAILER.  
 2 USE LEVEL FROM BACK CORNER OF SEAT  
 TO MARK CENTER LOCATION.

 <b>WISDOM INDUSTRIES</b>		Merino, CO 80741	
SCALE: N.T.S	APPROVED BY:		DRAWN BY: MFK
DATE: 08-25-94			REVISED
DESCRIPTION			
SEAT INSPECTION HOLE LOCATIONS			
EQUIPMENT:		DRAWING NUMBER	
SIZZLER		01 101	



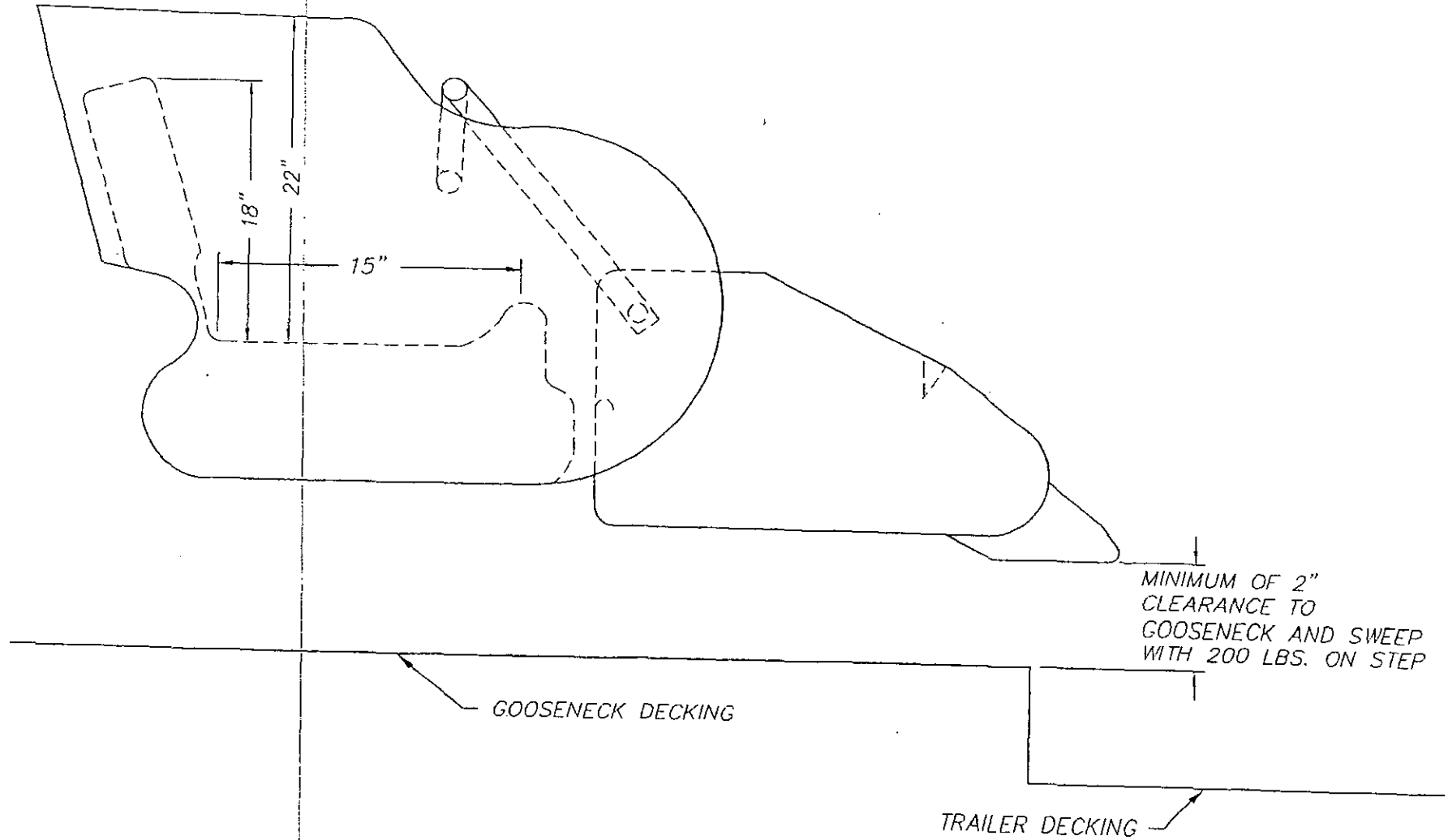

EQUIPMENT:

DRAWN BY:

DRAWING NUMBER:

DESCRIPTION:

SEAT INSPECTION GUIDE



WISDOM INDUSTRIES

Merino, CO 80741

APPROVED BY:

SOLENOID MOUNT FOR SAFETY BAR LOCK

FIBERGLASS SHELL

HANDLE BAR

SLEEVE FOR 5/8" Ø BOLTS TO HOLD FOOT REST  
CHECK WELD ON SLEEVE FOR CRACKS

FOOT TUB SHELL

7/16" Ø GRADE 5 BOLTS (THREADED INTO CHANNEL FLANGES) WITH LOCKWASHERS AND LOCKTITE ON THREADS ON BOTH ENDS OF SEAT

INSPECTION HOLE (BOTH SIDES)

HANDLE BAR

METAL LOCK NUT REQUIRED ON BOTH HINGE BOLTS

PLAIN WASHER 2" O.D. X 5/8" I.D. 1/8" THICK

GRADE 5 HEX HD BOLT 5/8" X 4 1/2" LG

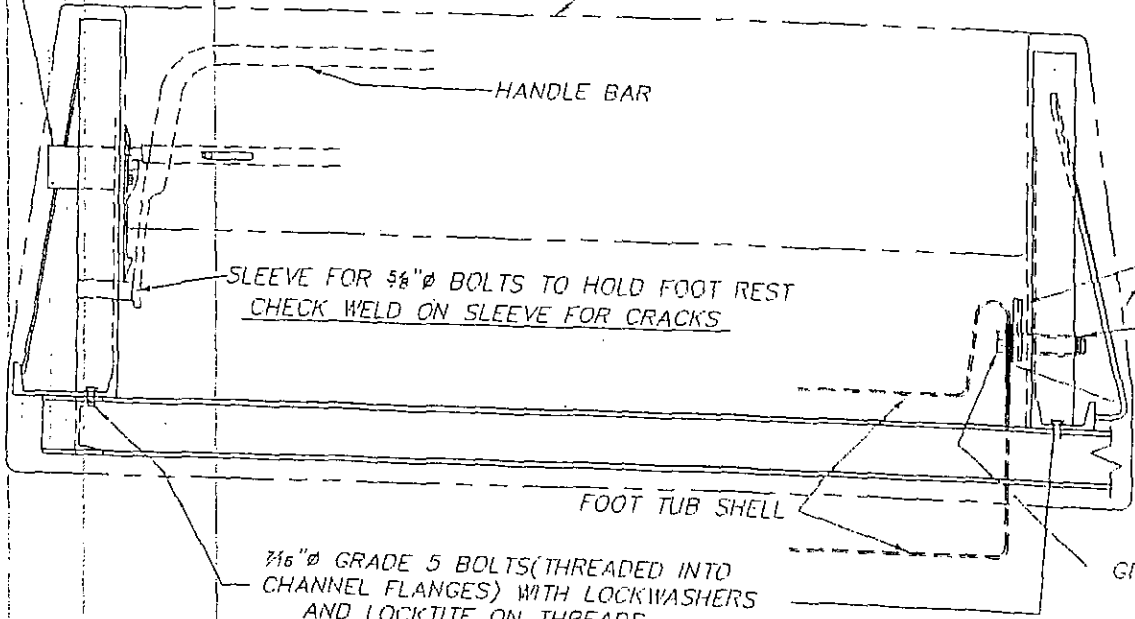

SCALE: NTS

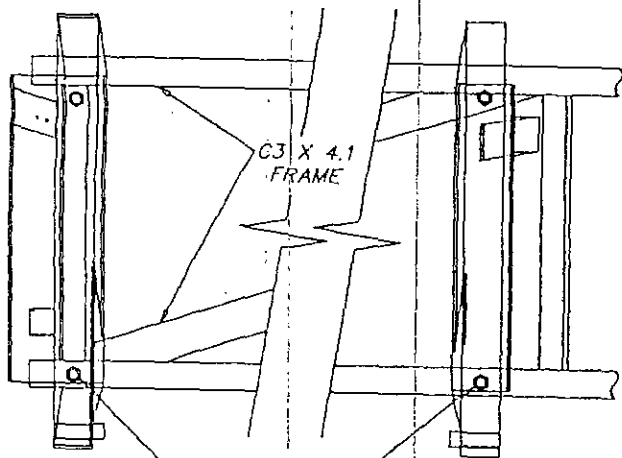
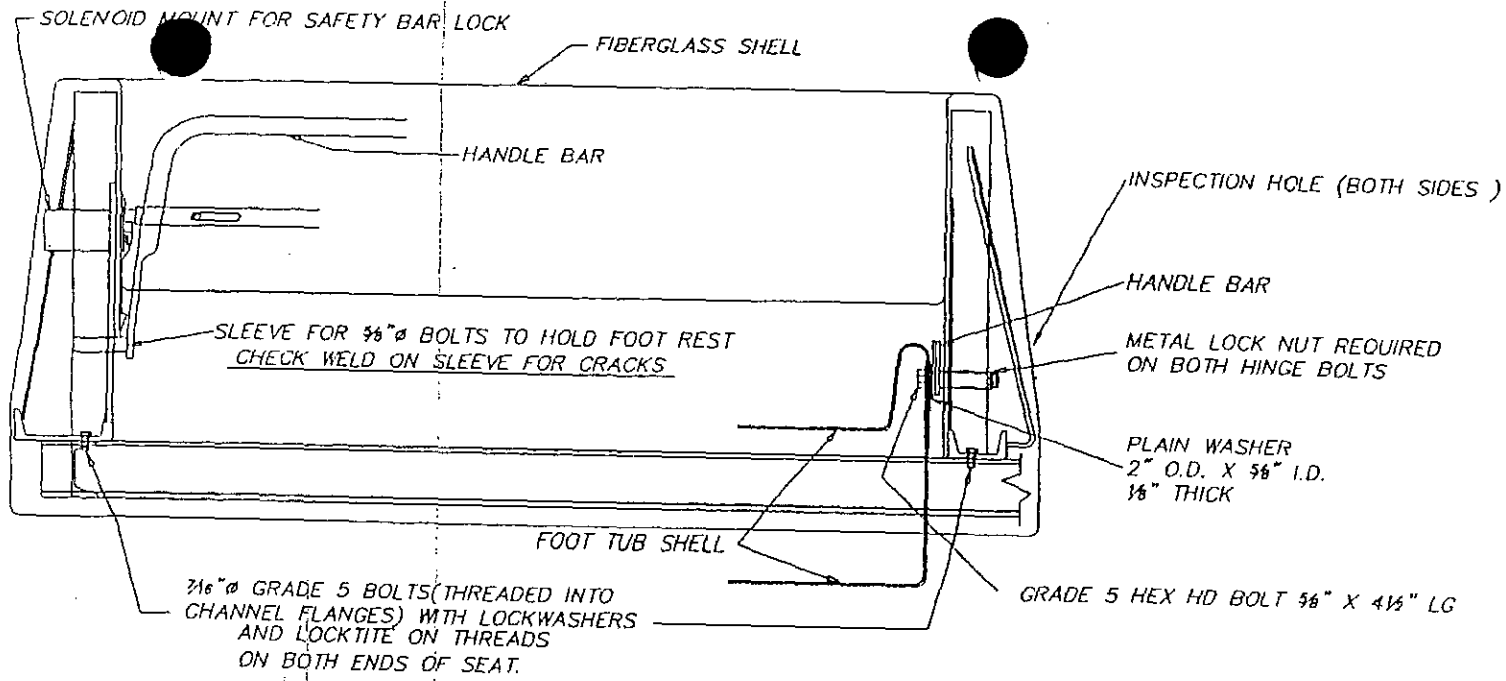

VIEW OF SIZZLER BOLT PATTERN

7/16" Ø GRADE 5 BOLTS  
HEAD SIZE IS 5/8"  
TORQUE TO 60 FOOT POUNDS  
CHECK HEAD FOR GRADE 5 MARKINGS

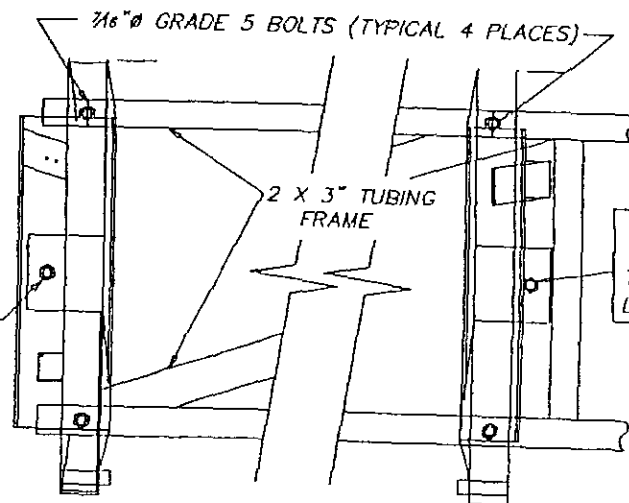

VIEW OF DELUXE SIZZLER BOLT PATTERN

1/2" Ø GRADE 5 BOLTS  
HEAD SIZE IS 3/4"  
TORQUE TO 75 FOOT POUNDS  
LOCKNUT MUST BE USED.

<b>WISDOM INDUSTRIES</b> Merino, CO 80741		DRAWN BY: SFH REVISED
SCALE: NTS	APPROVED BY:	INSIDE CONSTRUCTION OF SEAT
DATE: 6-01-98	DESCRIPTION	
EQUIPMENT:		DRAWING NUMBER <b>01-519SB3</b>
SIZZLER		



August 25, 1994

### SIZZLER SEAT INSPECTION COMPLIANCE NOTICE

SIZZLER SERIAL NUMBER \_\_\_\_\_

DATE INSPECTED \_\_\_\_\_

OWNER COMPANY NAME \_\_\_\_\_

OWNER ADDRESS \_\_\_\_\_  
\_\_\_\_\_  
\_\_\_\_\_

NUMBER OF SEAT FRAME BOLTS LOOSE \_\_\_\_\_

NUMBER OF SEAT FRAME BOLTS BROKEN \_\_\_\_\_

NUMBER OF SEAT FRAME BOLTS MISSING \_\_\_\_\_

We no longer own this ride

The Sizzler was sold to \_\_\_\_\_  
Address \_\_\_\_\_  
\_\_\_\_\_  
\_\_\_\_\_

INSPECTED BY (Print name) \_\_\_\_\_

SIGNATURE \_\_\_\_\_

Return to: Wisdom Industries  
Box 5000  
Sterling, CO. 80751



September 08, 1997

James Murphy  
BLUE GRASS SHOWS

RE: Sizzler Seat Iron Bolts.

Dear Mr. Murphy:

The 4 main 7/16 inch seat iron bolts (2 each iron) should be torqued to 30 foot pounds. The nuts that are under the seat sweep frame can be tack welded to the seat sweep frame to facilitate tightening the bolts and checking the torque in the future.

Access to the nuts would be by removing the seat liner from inside the car. There is no need to remove the foot tub to perform this procedure.

The nuts would have to be removed to remove the seat body from the frame in the future.

The 2 center 1/2 inch bolts have their nuts already tacked when assembled here. The torque for the 1/2 inch bolts is 40 foot pounds.

If you have any questions about this procedure please contact me at 800-634-6097.

**RECEIVED**

SEP 10 1997

BUREAU OF  
FAIR RIDES INSPECTION

Sincerely,

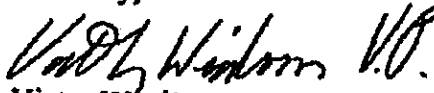

Victor Wisdom  
Vice President  
Wisdom Industries, Ltd.



January 27, 1999

NDT inspection of the main centerpole shaft is required if the axle has been flipped from under the trailer.

One method to determine if this ride has been dropped, is visual inspection of surrounding structural members at the rear of the trailer.

Are there indications of damage to the trailer frame? Is the rear of the trailer bent up? Has the frame been cut and rewelded? Is there indication of damage or repairs to the axle carrier? A careful visual and or magnaflux of lower gussets for indications of cracks or rewelding is a very good indication of further inspection.

If removal is required, this is a good time to replace the upper and lower bearings.

If there are no indications of this ride being dropped or damaged this may not be necessary.



WISDOM INDUSTRIES, INC



## NOTICE

**DATE:** FEBRUARY 17, 1999

**RIDE:** SIZZLER

**SUBJECT:** HEIGHT REQUIREMENTS

**COMPLIANCE:** MANDATORY

**COMPLETION DATE:** IMMEDIATELY

It has been requested that we provide a height, rather than the 11 year old limit to ride alone.

### CURRENT PASSENGER HEIGHT REQUIREMENTS FOR THE SIZZLER

Minimum passenger height- 36"

Passenger must be accompanied by a responsible adult- 36-52"

Passengers must be over 52" to ride alone

Replace any signage or data plate that does not reflect this height requirement.

If you need a data plate for your Sizzler contact Wisdom Industries with your ride Serial # and we will provide a plate for you.



March 7, 2000

To Whom It May Concern:

The amusement ride known at the Sizzler does have some NDT requirements.

In particular the cabbage head ears do require an annual NDT inspection, as per our notice dated July 1994. This applies to the early models with the single ear attached to the cabbage ear.

Enclosed is a copy of the requirements for NDT inspections on the older Sizzlers.

This is not required on the Deluxe Sizzler or the Super Sizzler nor later Sizzlers with the double ears.

There is an additional circumstance regarding a trailer dropped by the axle flipping out from underneath it. If it is determined this may have occurred, then the main center pole shaft must be NDT inspected.

Any other inspections are visual unless indications of defects are found.

James R. Merrell

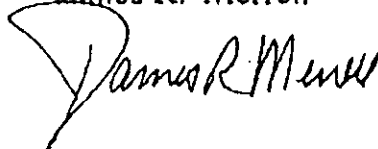



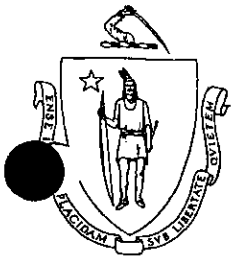

Mitt Romney  
Governor

Kerry Healey  
Lieutenant Governor

# The Commonwealth of Massachusetts

## Department of Public Safety

One Ashburton Place, Room 1301  
Boston, Massachusetts 02108-1618

Phone (617) 727-3200

Fax (617) 727-5732

Edward A. Flynn  
Secretary

Thomas G. Gatzunis, P.E.  
Commissioner

September 20, 2004

To: All Owners / Operators of Amusement Devices

From: Thomas G. Gatzunis, Commissioner

RE: **Suspension of Permit to Operate Wisdom "Sizzler" Amusement Rides**

The Massachusetts Department of Public Safety is immediately suspending all permits to operate any and all Wisdom "Sizzler" amusement rides until owners have complied with this directive.

You are directed to perform a thorough review of each car to ensure that the proper bolts and lock nuts as specified by the manufacturer are in place and secure. Use of alternate or smaller bolts and/or nuts that are not in accordance with the ride manufacturer are expressly prohibited.

As per design, each car side panel is secured with two (2) - 7/16 inch grade 5 bolts that screw into tapped holes at the base of the seat frame. Use of smaller sized bolts is prohibited unless engineered and approved by the ride manufacturer.

Verification shall be performed by removing the fiberglass seat on each car. This will enable you to view the bolt closely to ensure proper sizing and grade as designed by the manufacturer.

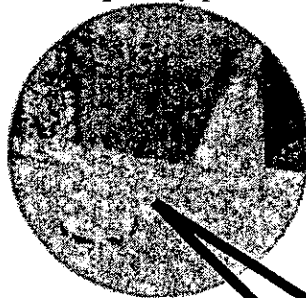

(two bolts per side panel)

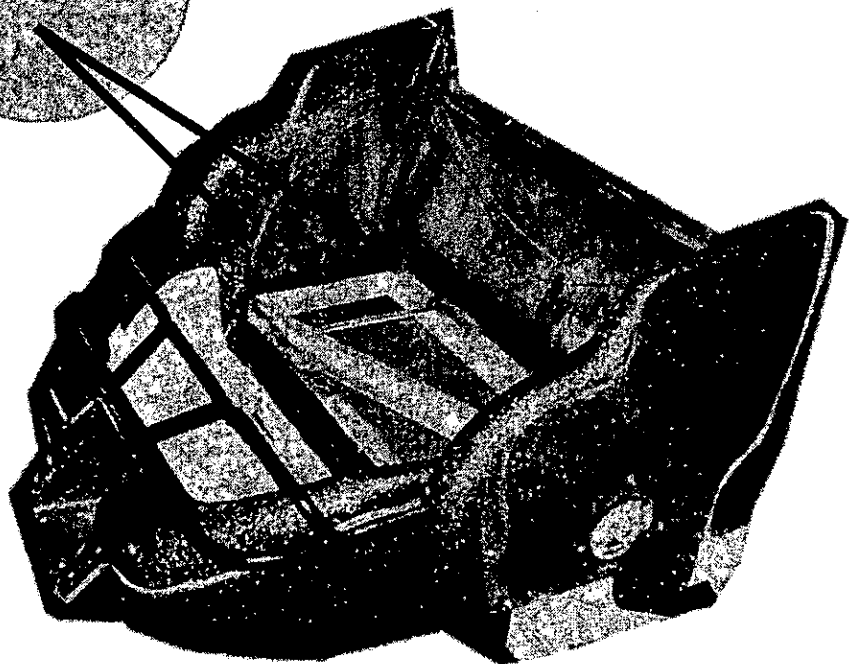

The lap restraints and foot tub are secured to the car side panels with two (2) 5/8" (requires use of a 16" socket), grade 5 bolts secured with lock nuts. These nuts shall be tightened as specified by the manufacturer. These nuts can be viewed and tightened from the side access panels on the car. Use of nuts that do not have locking capacity is prohibited.

Once you have completed the review on your ride, you are directed to provide a written report to the Department verifying compliance with this directive, under the signature of the owner and the person who performed the physical inspection, before the permit to operate this ride is re-issued.

This order shall remain in effect until such time that the Department has cleared your ride for permitting.

Failure to comply with this directive will result in the immediate suspension/revocation of your permits to operate all amusement rides in the Commonwealth.

If you have any questions, please feel free to call Assistant Chief of Inspections, Mark Mooney at (617) 727-3200 ext. 25208.

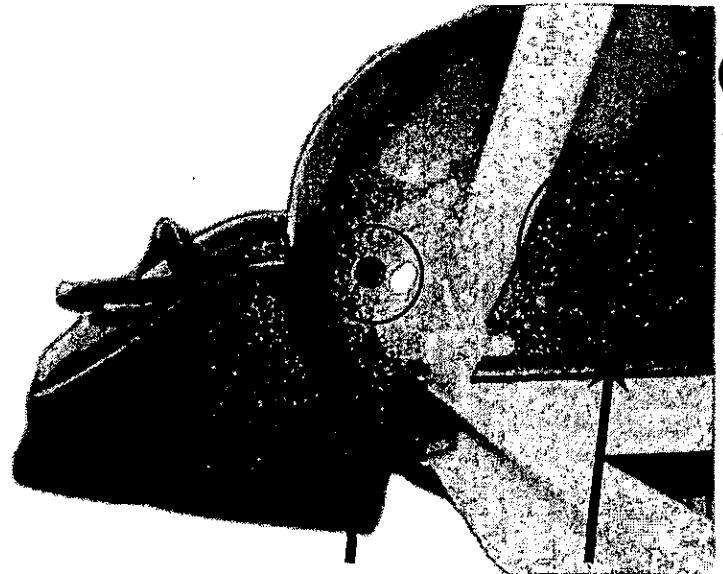

*Location of 5/8" locknut*

*Access Port*

*Edward A. Flynn, Secretary of Public Safety  
Mark F. Mooney, Assistant Chief of Inspections  
C.A.R.E.S member jurisdictional authorities  
Bev Kohen, Regional Director, USCPSC*



# WISDOM INDUSTRIES, Ltd.

## SERVICE BULLETIN

**DATE: SEPTEMBER 24, 2004**  
**RIDE: SIZZLER**  
**SUBJECT: FOOT TUB CLEARANCE**

**❖ THE ATTACHED BULLETINS ARE STILL APPLICABLE  
FOR INSPECTION OF THE SIZZLER AMUSEMENT RIDE.**

- 1. The nuts used on the foottub hinge bolts must be lock nuts. If the nuts are to be removed and replaced new nuts must be used. Double nutting is not acceptable.**
- 2. The seat iron bolts are still 7/16 inch grade 5 or better. The inspection holes can be used to inspect the appropriate size and tightness of these bolts.**
- 3. The foottub hinge bolt must allow the foottub to fold up without binding.**
- 4. Check the seat iron hinge pipe for cracking around the pipe where it is welded to the seat iron frame.**
- 5. The clearance of the foottub to the gooseneck as well as the sweep that the car crosses over must be 2 inches with a person standing in the nose of the seat. Adjustments can be made by shimming the foottub between the lower edges of the seat to raise the nose of the foottub for clearance.**
- 6. Follow the enclosed bulletins for checking the condition of the foottub internal hinge plate for wear and corrosion.**
- 7. Any questions, contact Wisdom Industries Ltd.**

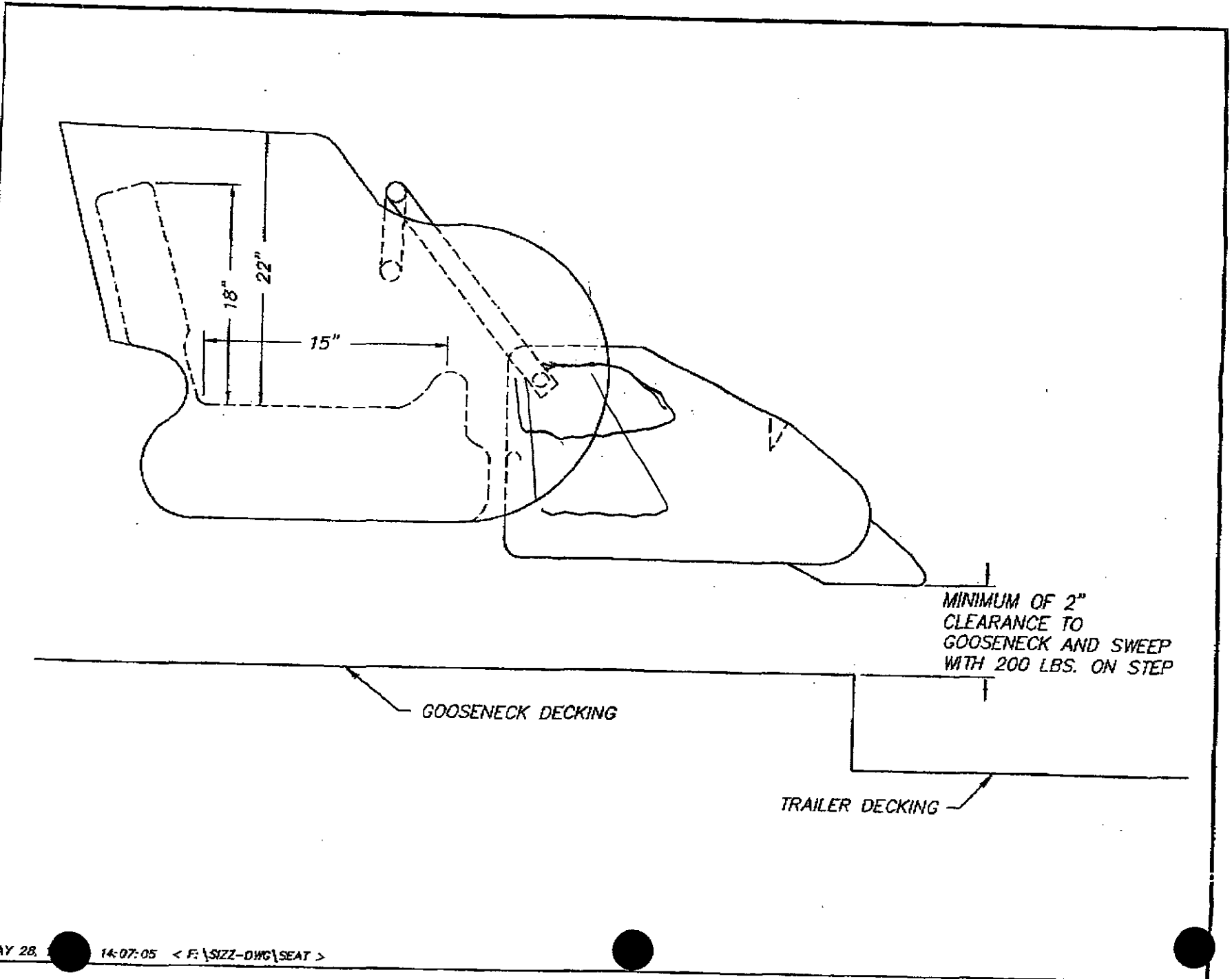



**WISDOM  
INDUSTRIES, Ltd.**

# SAFETY BULLETIN

**DATE: SEPTEMBER 27, 2004**  
**RIDE: SIZZLER AND DELUXE SIZZLER ONLY**  
**SUBJECT: SIZZLER SEAT FRAME INSPECTION**  
**TIME: IMMEDIATE**

- **INSPECT THE INTERNAL FRAME ATTACHMENT BOLTS FOR PROPER SIZE AND THE FOOT TUB HINGE BOLTS FOR LOCKNUTS.**
  
- **INSPECT FOOT TUB HINGE BOLTS FOR LOCKNUTS.**
  
- **All 5/8 inch foottub hinge bolts must have locknuts installed. During this inspection of the seat internal frame bolts inspect that the hinge bolts have locknuts installed.**
  - **Warning NEVER reuse locknuts**
  - **Only use all metal locknuts on the hinge bolts.**

**Inspection procedure on following page.**

## **THE INSPECTION OF THE SIZZLER RIGHT SIDE SEAT INTERNAL FRAME MOUNTING BOLTS.**

SIZZLERS WITH THE PLASTIC "S" PANEL OR THE FIBERGLASS COVERS OVER THE SEAT UNLOCKING SOLENOIDS.

1. Remove the "S" panel or the fiberglass cover on the right side of the car.
2. Reach down into the seat and check to see that the two mounting bolts in the frame are tight. If the bolts are loose, broken, or missing remove them and reinstall using Loctite to secure the bolts.
3. If you are unable to reach the bolts through the hole, follow these steps: **"FOR SIZZLERS THAT DO NOT HAVE "S" PANELS."**

### **FOR SIZZLERS THAT DO NOT HAVE THE "S" PANELS**

1. Remove the two bolts holding the seat lock brass to the side of the car.
2. Slide out the quarter side panel and check the two internal frame mounting bolts for tightness. Replace if they are loose or broken and use Loctite.

### **FOR INSPECTION OF THE LEFT SIDE SEAT IRON**

1. Remove seat line **OR** cut a hole in the left side of the car body using a hole saw. Review the enclosed drawing for the location of the hole. Using a minimum of a 3" hole saw up to 5" diameter.
2. Locate the hole. Drill the hole through the fiberglass and inspect the two mounting bolts. If you would like a cover for this hole, contact us and we will provide inspection covers for these holes.
3. Check the bolts for looseness, missing bolts or sheared bolts and replace with grade 5-7/16" fine thread bolts and Loctite if needed.

Please notify Wisdom Industries following this inspection and notify us to the status of the bolts on your ride. If you have any questions, please contact Wisdom Industries at 800-634-6097.

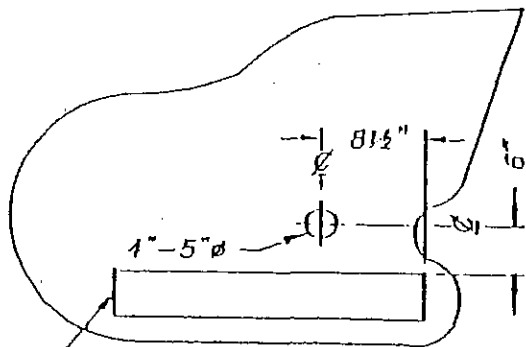

SWEEP CUT OUT

LEFT SIDE OF SEAT

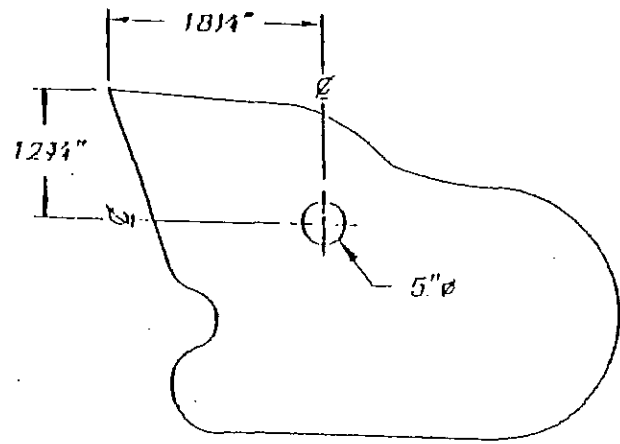

RIGHT SIDE OF SEAT

IF RIGHT SIDE INSPECTION HOLE IS DESIRED.  
 NOTE: 1 LEVEL TRAILER.  
 2 USE LEVEL FROM BACK CORNER OF SEAT  
 TO MARK CENTER LOCATION.

 <b>WISDOM INDUSTRIES</b> Merino, CO 80741		
SCALE: N.T.S.	APPROVED BY:	DRAWN BY: MFK
DATE: 08-25-94		REVISED:
DESCRIPTION		
SEAT INSPECTION HOLE LOCATIONS		
EQUIPMENT:		DRAWING NUMBER
SIZZLER		SEAT



WISDOM  
INDUSTRIES

Merino, CO 80741

APPROVED BY:

EQUIPMENT:

SIZZLER

SEAT INSPECTION GUIDE

DRAWN BY:

M. HICKAM

SCALE:

N.T.S.

DRAWING NUMBER:

01519SR

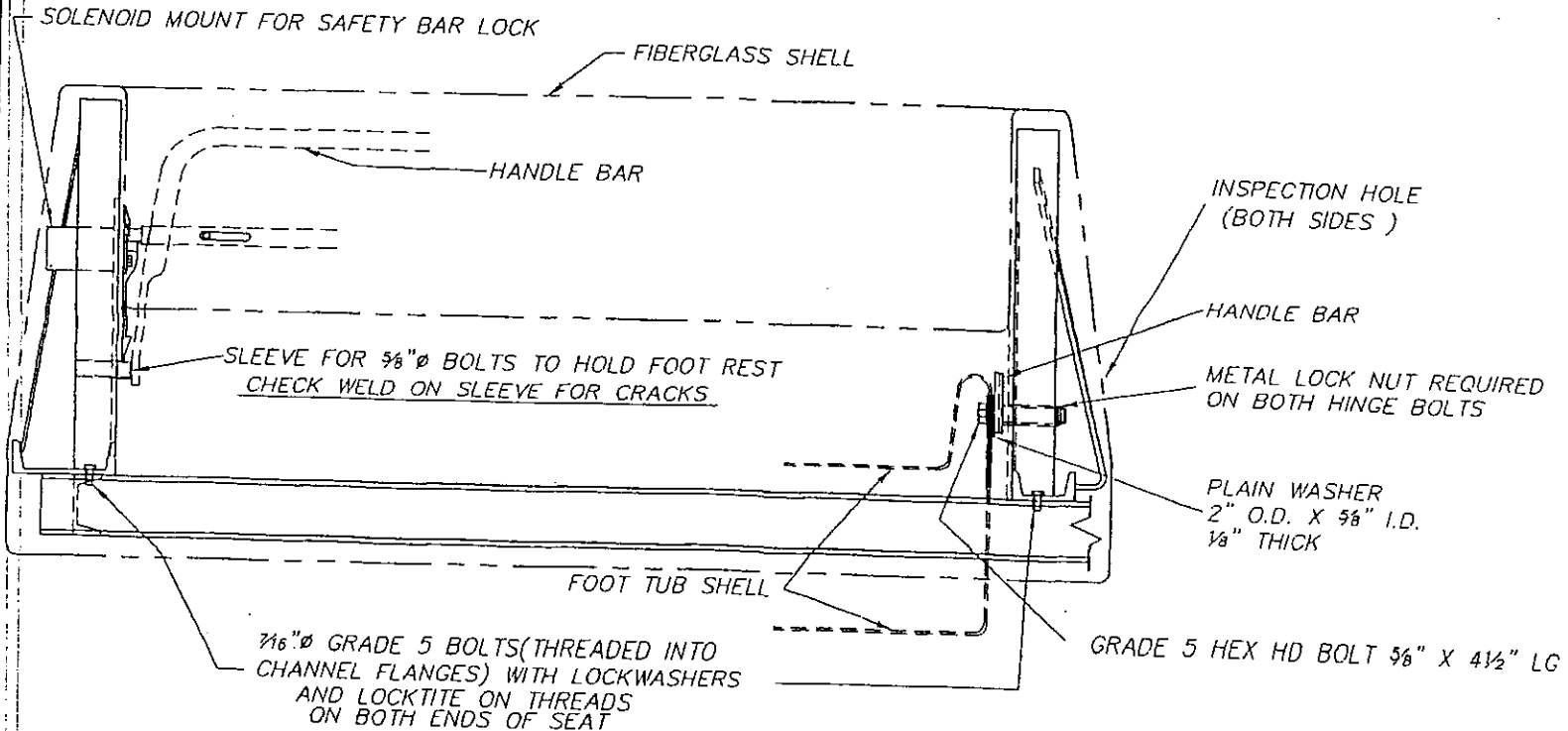



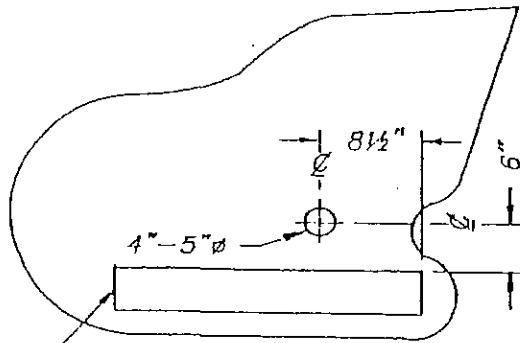

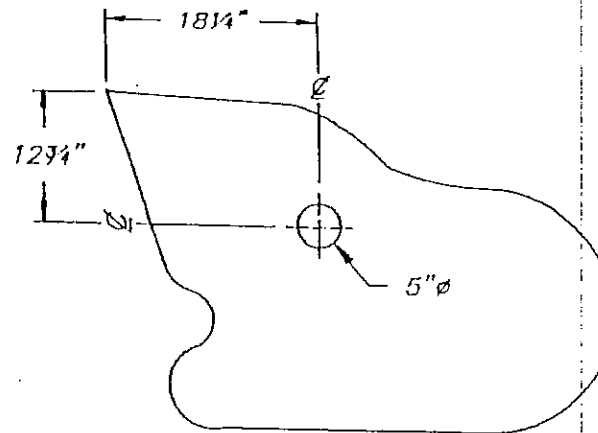

SWEEP CUT OUT

LEFT SIDE OF SEAT



RIGHT SIDE OF SEAT

IF RIGHT SIDE INSPECTION HOLE IS DESIRED.  
 NOTE: 1 LEVEL TRAILER.  
 2 USE LEVEL FROM BACK CORNER OF SEAT  
 TO MARK CENTER LOCATION.

 <b>WISDOM INDUSTRIES</b> Merino, CO 80741	
SCALE: N.T.S.	APPROVED BY:
DATE: 08-25-94	DRAWN BY: MFK
DESCRIPTION	
SEAT INSPECTION HOLE LOCATIONS	
EQUIPMENT:	DRAWING NUMBER
SIZZLER	SEAT



**WISDOM  
INDUSTRIES, Ltd.**

# SAFETY BULLETIN

**DATE:** OCTOBER 12, 2004  
**RIDE:** SIZZLER AND DELUXE SIZZLER ONLY  
**SUBJECT:** SIZZLER SEAT FRAME AND FOOT TUB  
ATTACHMENT INSPECTION  
**TIME:** IMMEDIATE  
**FREQUENCY:** ANNUAL

❖ **WARNING: FAILURE TO PERFORM THIS INSPECTION CAN RESULT IN SERIOUS INJURY TO YOUR PASSENGERS.**

▪ **KEY INSPECTION POINTS OF THIS BULLETIN**

1. Inspect, grade & torque of the 4 internal frame bolts.
2. Inspect foottub hinge bolts for proper grade and all metal locknut installed.
3. Inspect internal frame welds.

❖ **INSPECTION PROCEDURE TO BE FOLLOWED IS ON ATTACHED PAGES AND DRAWING.**

❖ **NOTE:** If replacement bolts are needed contact Wisdom Industries for replacement. If the bolts are purchased locally verify grade 5 bolts by the head marking (See drawing). Many hardware stores only sell grade 2 or 3 bolts. These bolts are unacceptable and dangerous.

**THE INSPECTION OF THE SIZZLER RIGHT SIDE (SEAT LOCK SIDE) SEAT INTERNAL FRAME MOUNTING BOLTS.**

1. Remove the two ¼ inch bolts holding the seat lock brass to the side of the car.
2. Slide out the side quarter panel.
3. Inspect the two internal frame mounting bolts for proper Grade 5.

4. Replace if they are loose or broken and use Red Loctite.
5. Inspect bolts for proper 7/16 inch diameter. Check proper head size using a 5/8 inch socket.
6. Check that torque of 7/16 inch bolt is 60 foot pounds .

➤ **NOTE: IF BOLT IS LOOSE REMOVE THE BOLT CLEAN THREADS WITH WIRE BRUSH AND APPLY RED LOCKTITE. TORQUE BOLT TO 60 FOOT POUNDS.**

7. Verify that the foottub hinge nut is a 5/8 inch all metal lock nut.

- Warning NEVER reuse locknuts
- Only use all metal locknuts on the hinge bolts.
- Inspect hinge pipe welds for cracks.

### **FOR INSPECTION OF THE LEFT SIDE (SPINDLE SIDE) SEAT IRON BOLTS.**

○ **IF THE INSPECTION HOLE IS NOT INSTALLED**

1. Remove seat liner to perform annual inspection.
2. Cut a hole in the left side of the car body using a hole saw. Review the enclosed drawing for the location of the hole. Use a 5 inch diameter hole saw.
3. Inspect the two internal frame mounting bolts for proper Grade 5.
4. Replace if they are loose or broken and use Red Loctite.
5. Inspect bolts for proper 7/16 inch diameter. Proper head size of a 7/16 inch bolt uses a 5/8 inch socket.
6. Check that torque of 7/16 inch bolt is 60 foot pounds.

➤ **NOTE: IF BOLT IS LOOSE REMOVE THE BOLT CLEAN THREADS WITH WIRE BRUSH AND APPLY RED LOCKTITE. TORQUE TO 60 FOOT POUNDS.**

6. Verify that the foottub hinge nut is a 5/8 inch all metal lock nut.

- Warning NEVER reuse locknuts
- Only use all metal locknuts on the hinge bolts.
- Inspect hinge pipe welds for cracks.

### **REASSEMBLY**

Reassemble fiberglass quarter panel and seat lock brass  
Perform lapbar inspection procedure on following page.

*The Amusement Ride Safety Bulletin below is for use by State Amusement Ride Officials. We have in the past shared information with state and local authorities regarding amusement ride safety pursuant to Section 29(e) of the Consumer Product Safety Act, 15 U.S.C. 2078(e), and have asked that the information not be released to the public, as required by that statute. However, in this instance, Wisdom Industries, Ltd. has agreed to the public release of this information, and therefore the usual restriction does not apply.*

**AMUSEMENT RIDE SAFETY BULLETIN**  
**Sizzler and Deluxe Sizzler Amusement Rides**  
**October 18, 2004**

The U.S. Consumer Product Safety Commission (CPSC) staff is notifying state and local authorities having jurisdiction over amusement rides that we are investigating the Sizzler and Deluxe Sizzler Amusement Rides. CPSC staff are working with Wisdom Industries, Ltd to inspect and correct as necessary existing Sizzler and Deluxe Sizzler Amusement Rides.

On September 19, 2004, an incident occurred on a Sizzler ride operating in Massachusetts resulting in the death of one passenger and the injury of two other people when the end of the seat structure gave way allowing the two occupants to be thrown out of the ride. As a result of the incident, Wisdom Industries, Ltd. is requesting that all owner/operators of the Sizzler and Deluxe Sizzler rides immediately perform the critical safety inspections detailed in the attached bulletin. In addition, the U. S. Consumer Product Safety Commission (CPSC) is requesting State and Local officials to locate these rides and require owners to cease operation of the Sizzlers until they complete a thorough inspection of the internal frame bolts, the foottub hinge bolts and internal frame welds.

**The key Inspection Points of Wisdom's Bulletin:**

*Before a Sizzler ride is allowed to operate, owner/operators must:*

1. Inspect, grade and torque the four (4) internal frame bolts.
2. Inspect foottub hinge bolts for proper grade and all metal locknuts installed.
3. Inspect internal frame welds.
4. Return attached verification of inspection form to Wisdom Industries, Ltd.

NOTE: CPSC staff has worked with Wisdom to update the inspection and maintenance bulletins previously distributed by Wisdom that applied to these bolted and welded joints. These updated bulletins are attached to this notice and should be used to perform the required inspection and repairs.

CPSC staff continues to work with Wisdom Industries Ltd. to resolve any safety issues related to this ride and the September 19<sup>th</sup> incident. Based upon what we now know, CPSC recommends that you not allow Sizzlers and Deluxe Sizzlers to operate, unless they meet the requirements of the

**Wisdom program. Please contact me if you have any questions or comments on this matter.**

**Roy W. Deppa  
Associate Director  
Office of Compliance  
301-504-7514**



# SAFETY BULLETIN

**DATE:** OCTOBER 18, 2004  
**RIDE:** SIZZLER AND DELUXE SIZZLER ONLY  
**SUBJECT:** SIZZLER SEAT FRAME AND FOOT TUB  
ATTACHMENT INSPECTION  
**TIME:** IMMEDIATE  
**FREQUENCY:** ANNUAL

❖ **WARNING: FAILURE TO PERFORM THIS INSPECTION CAN RESULT IN SERIOUS INJURY TO YOUR PASSENGERS.**

▪ **KEY INSPECTION POINTS OF THIS BULLETIN**

1. Inspect, grade & torque of the 4 internal frame bolts.
2. Inspect foottub hinge bolts for proper grade and all metal locknut installed.
3. Inspect internal frame welds.

❖ **INSPECTION PROCEDURE TO BE FOLLOWED IS ON ATTACHED PAGES AND DRAWING.**

❖ **NOTE: If replacement bolts are needed contact Wisdom Industries for replacement. If the bolts are purchased locally verify grade 5 bolts by the head marking (See drawing). Many hardware stores only sell grade 2 or 3 bolts. These bolts are unacceptable and dangerous.**

**THE INSPECTION OF THE SIZZLER RIGHT SIDE (SEAT LOCK SIDE) SEAT INTERNAL FRAME MOUNTING BOLTS.**

1. Remove the two ¼ inch bolts holding the seat lock brass to the side of the car.
2. Slide out the side quarter panel.
3. Inspect the two internal frame mounting bolts for proper Grade 5.

4. Replace if they are loose or broken and use Red Loctite.
5. Inspect bolts for proper 7/16 inch diameter. Check proper head size using a 5/8 inch socket.
6. Check that torque of 7/16 inch bolt is 60 foot pounds .

➤ **NOTE: IF BOLT IS LOOSE REMOVE THE BOLT CLEAN THREADS WITH WIRE BRUSH AND APPLY RED LOCKTITE. TORQUE BOLT TO 60 FOOT POUNDS.**

7. Verify that the foottub hinge nut is a 5/8 inch all metal lock nut.
  - **Warning NEVER reuse locknuts**
  - **Only use all metal locknuts on the hinge bolts.**
  - **Inspect hinge pipe welds for cracks.**

### **FOR INSPECTION OF THE LEFT SIDE (SPINDLE SIDE) SEAT IRON BOLTS.**

#### **○ IF THE INSPECTION HOLE IS NOT INSTALLED**

1. Remove seat liner to perform annual inspection.
2. Cut a hole in the left side of the car body using a hole saw. Review the enclosed drawing for the location of the hole. Use a 5 inch diameter hole saw.
3. Inspect the two internal frame mounting bolts for proper Grade 5.
4. Replace if they are loose or broken and use Red Loctite.
5. Inspect bolts for proper 7/16 inch diameter. Proper head size of a 7/16 inch bolt uses a 5/8 inch socket.
6. Check that torque of 7/16 inch bolt is 60 foot pounds.

➤ **NOTE: IF BOLT IS LOOSE REMOVE THE BOLT CLEAN THREADS WITH WIRE BRUSH AND APPLY RED LOCKTITE. TORQUE TO 60 FOOT POUNDS.**

6. Verify that the foottub hinge nut is a 5/8 inch all metal lock nut.
  - **Warning NEVER reuse locknuts**
  - **Only use all metal locknuts on the hinge bolts.**
  - **Inspect hinge pipe welds for cracks.**

### **REASSEMBLY**

**Reassemble fiberglass quarter panel and seat lock brass  
Perform lapbar inspection procedure on following page.**

## **SIZZLER**

### **LAP BAR & SEAT LOCK INSPECTION PROCEDURE**

1. Raise lap bar and latch.
2. Check lap bar hinge bolts and pipe for wear or looseness.
3. Check lap bar arm for cracks.
4. Check that seat lock brass is tight.
5. Open lap bar.
6. Push seat lock pin. It must snap back out and not drag or catch.
7. Close lap bar. Seat lock pin must snap into the notch in the brass.  
3/8 inch minimum engagement of pin in brass.

➤ **NOTE: ELECTRIC SEAT UNLOCKING IS NOT MANDATORY.**

8. Activate electric unlocking system.  
**NOTE:** All seat locks should release.
9. Turn off electric unlocking system.  
**NOTE:** The timer will shut off the solenoids after about 15 seconds.
10. Go around seat to inside (spindle side) and pull on the lap bar sideways and out to try to pop seat lock pin out of the brass.
11. If bar comes open, tie off that car until repairs are made. Replace any components needed if the bar will come open.
12. Repeat for each seat.

#### **\*\*WARNING\*\***

Never install a bolt or knob to manually unlock the lapbar. Passengers have been known to open the bar while the ride is running and come out of the seat.

#### **\*\*NOTE\*\***

Each seat lock pin is custom drilled for each car and lap bar. Make sure the same pin goes back to the same bar on the same car.

**INSPECT CLEARANCE OF FOOTTUB TO SWEEP AND TRAILER GOOSENECK.**

**SEE ATTACHED BULLETIN.**

Please notify Wisdom Industries following this inspection and notify us to the status of the bolts on your ride. If you have any questions, please contact Wisdom Industries at 800-634-6097.



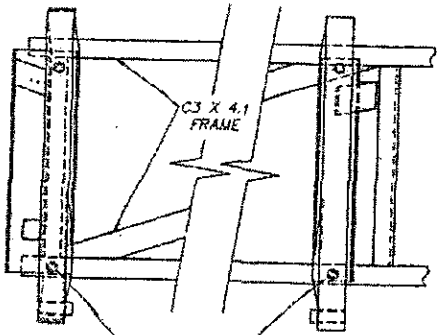
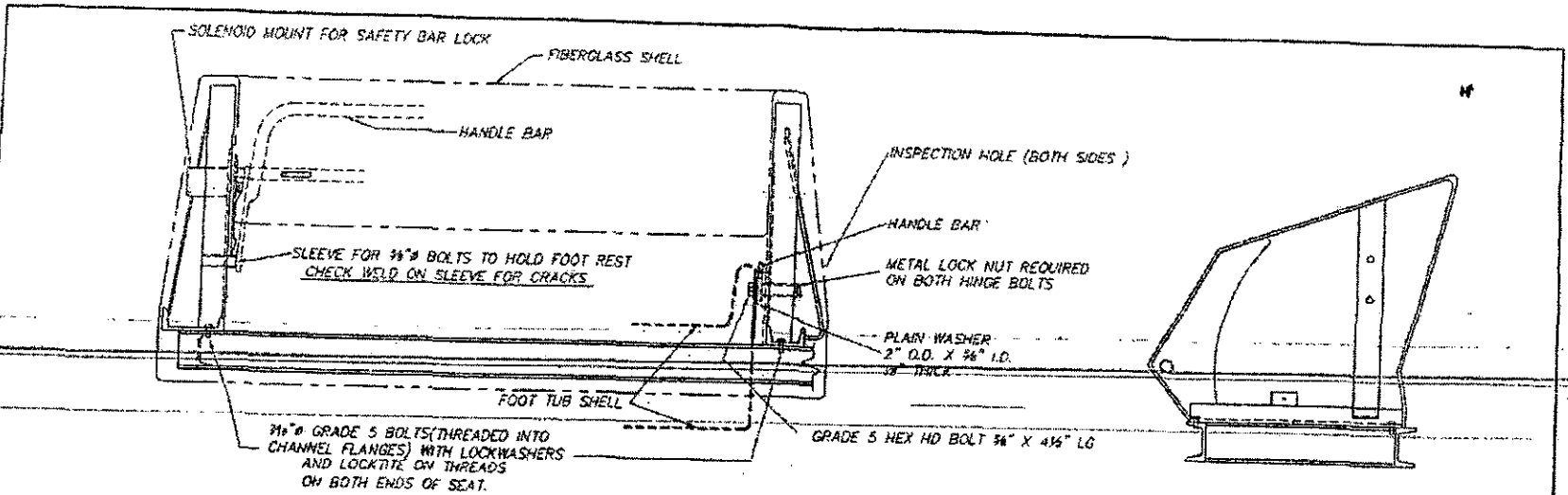

**VIEW OF SIZZLER BOLT PATTERN**

3/8" GRADE 5 BOLTS  
HEAD SIZE IS 5/8"  
TORQUE TO 60 FOOT POUNDS  
CHECK HEAD FOR GRADE 5 MARKINGS

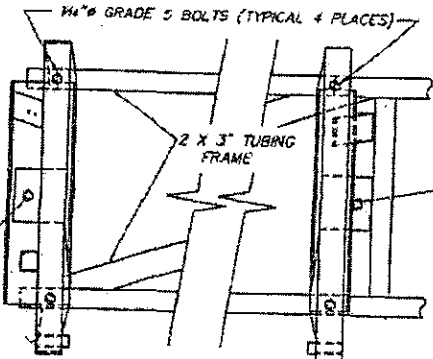

**VIEW OF DELUXE SIZZLER BOLT PATTERN**

1/2" GRADE 5 BOLTS  
HEAD SIZE IS 3/4"  
TORQUE TO .75 FOOT POUNDS  
LOCKNUT MUST BE USED.

<b>WISDOM INDUSTRIES</b> Merino, CO 80741	
SCALE: 1 1/2" = 1'-0"	APPROVED BY: <i>[Signature]</i>
DATE: 06/01/98	DESIGNED BY: <i>[Signature]</i>
DESCRIPTION: <b>INSIDE CONSTRUCTION OF SEAT</b>	
EQUIPMENT: <b>SIZZLER</b>	DRAWING NUMBER: <b>01 519</b>

OCT 06, 2004 - 10:13:25 < U:\SIZZ-DWG\0151958.DWG >

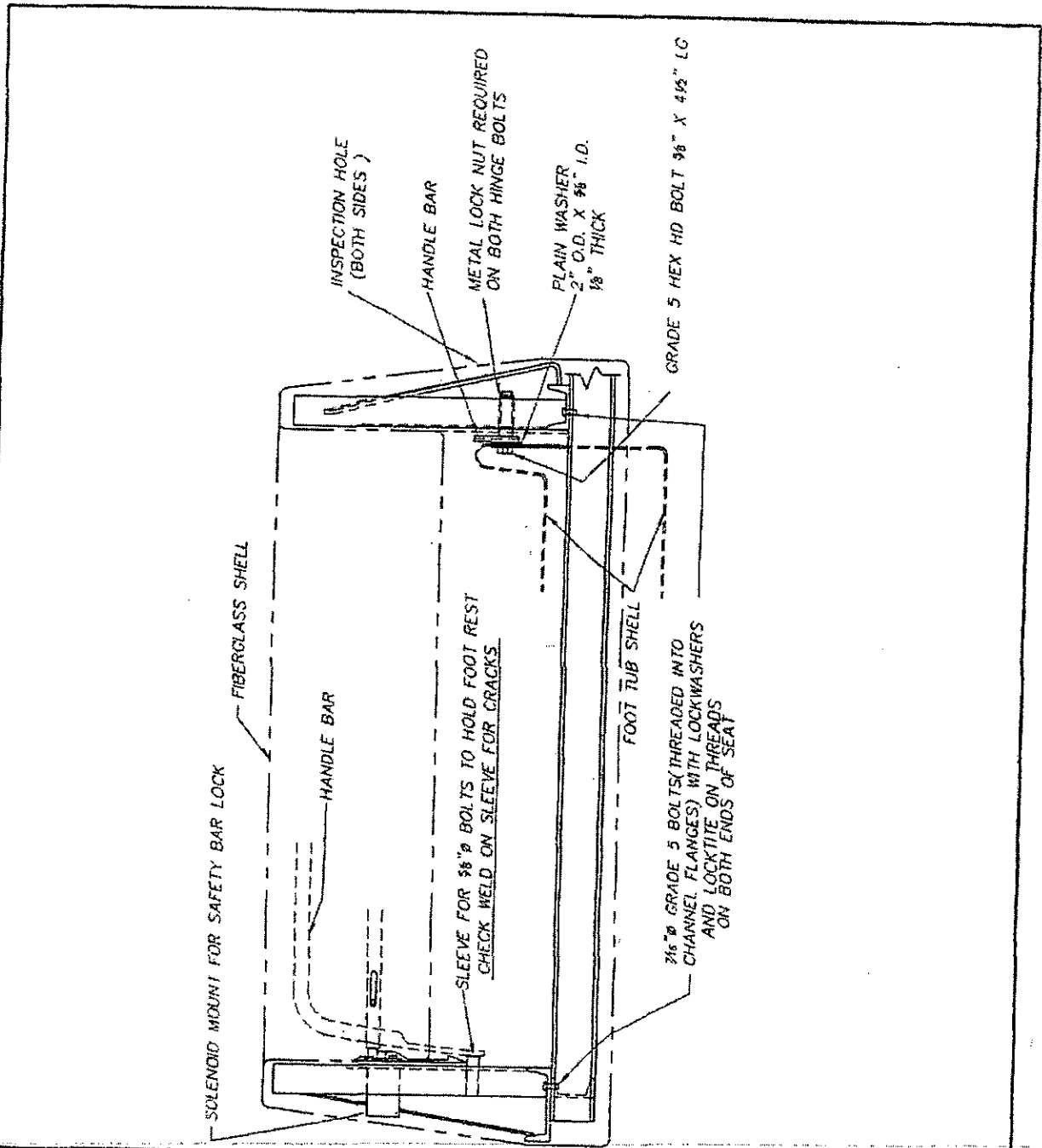

**WISDOM INDUSTRIES** Merino, CO 80741

APPROVED BY:

DESCRIPTION  
**SEAT INSPECTION GUIDE**

SCALE: NTS

EQUIPMENT:  
**SIZZLER**

DRAWN BY:  
**M.HICKAM**

DRAWING NUMBER:  
**01519SB**

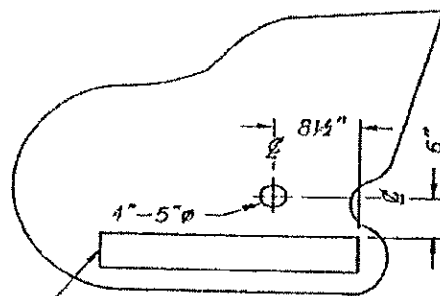

SWEEP CUT OUT

LEFT SIDE OF SEAT

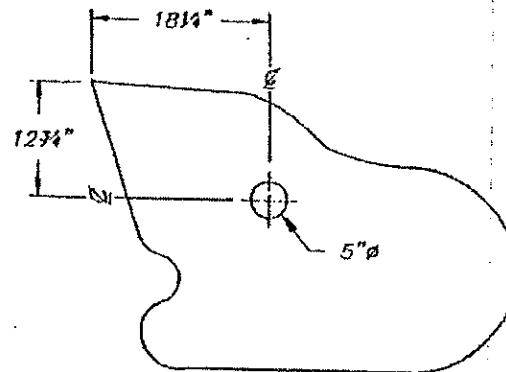

RIGHT SIDE OF SEAT

IF RIGHT SIDE INSPECTION HOLE IS DESIRED.

NOTE: 1 LEVEL TRAILER.

2 USE LEVEL FROM BACK CORNER OF SEAT TO MARK CENTER LOCATION.

 <b>WISDOM INDUSTRIES</b> Merino, CO 80741		
SCALE: N.T.S.	APPROVED BY:	DRAWN BY: MFK
DATE: 08-25-94		REVISED:
DESCRIPTION: SEAT INSPECTION HOLE LOCATIONS		
EQUIPMENT: SIZZLER		DRAWING NUMBER: SEAT

AUG 25, 1994 - 16:00:18 < P:\S22-DWG\SEAT >



COMMONWEALTH OF PENNSYLVANIA  
DEPARTMENT OF AGRICULTURE  
BUREAU OF RIDE AND MEASUREMENT STANDARDS  
AMUSEMENT RIDE SAFETY DIVISION

**TO:** Owners and Inspectors of Sizzler rides Manufactured by Wisdom, registered in Pennsylvania and interested parties.

**FROM:** Joseph G. Filoromo, supervisor

**SUBJECT:** Safety Alert Possibility of deteriorated structural members

**DATE:** February 23, 2005

\*\*\*\*\*

It has come to my attention that there may be a dangerous condition with regard to Sizzler Rides.

Please do a detailed inspection of the areas outlined below before further operation of Sizzlers. Look closely for swelling of the fiberglass or rust weeping from the designated area. If there is any question about the integrity of steel parts that are encapsulated in Fiberglass, non destructive testing is recommended. All repairs must be done in accordance with the manufacturer's specifications.

There is a steel plate that is encapsulated in fiberglass on the side of the footrest of the Sizzler seat. The plate has a hole with a steel bushing welded in it that, with a bolt, serves as the attachment point to the seat. It is evident that these steel plates may deteriorate under the fiberglass and break off, therefore dropping the foot tub. If the foot tub drops, I suspect that it can come in contact with the trailer or the sweep, with destructive and possible disastrous results. The plate is located inside the fiberglass, at the top right hand corner of the small picture below.

Please see the pictures of damaged plates that have been removed form Sizzler Seats on Page 2.

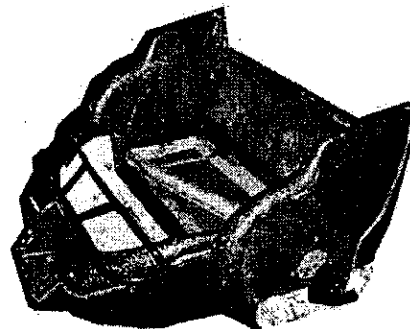



This badly damaged part was still inside the fiberglass and could have gone undetected. This part is unacceptable.



This part shows the beginning of the deterioration process. This part is also unacceptable.

Please feel free to contact me with any questions regarding this issue.

Thank You,

Joe Filoromo, Supervisor

Room G-4  
2301 North Cameron Street  
Harrisburg PA 17110-9408

Emergency 800-573-1352

Telephone- 717-787-2291  
E-Mail- [jfiloromo@state.pa.us](mailto:jfiloromo@state.pa.us)  
Fax- 717-783-4158



**WISDOM  
INDUSTRIES, Ltd.**

## **SERVICE BULLETIN**

**DATE: MARCH 7, 2005**  
**RIDE: SIZZLER**  
**SUBJECT: FOOTTUB BOLT ON PLATE ASSEMBLY**

Recent Inspections of Sizzler foottub internal steel pivot plates have shown corrosion of the laminated steel. Inspection of the plates should be performed for all Sizzlers that are 8 years and older.

Plates that are corroded more than 20% of their thickness must be replaced.

An alternative to performing this inspection is to install a bolt on pivot plates or laminate galvanized plates into the foot tub.

A bolt on pivot plate kit is available that can be inspected without removing the fiberglass or foottub.

### **INSPECTION OF LAMINATED PLATES**

1. Remove foottub from seat.
2. Grind from the inside the fiberglass overlaying the steel plates
3. Measure the thickness of the plate next to the boss. Plates that are cracked at the boss or measure less than .100" thick must be replaced. Prime, paint or galvanize plate before reinstalling.
4. Clamp plate into position.
5. Glass mat must extend 3 inches beyond the plate
6. Sand foot tub area that is to be glassed with 80 grit sandpaper.
7. Fiberglass over the plate with 3 layers of glass matt. Use quality polyester resin when glassing in the plate.
8. Reinstall foottub using NEW all steel locknut.
9. Measure clearance to gooseneck and sweep according to the attached instructions.
10. Check lap bar latching according to the attached procedure
11. Repeat on other side of foottub.

## GALVANIZED PLATES

1. Remove non galvanized original plate
2. Clamp new plate into position and laminate into place using steps 4-11 in the inspection procedure.
  - NOTE: A small section of the plate can be left exposed to show that the plates are galvanized for subsequent inspections.

## BOLT ON PLATES

1. Remove Lock nut from foottub pivot bolt
2. Remove pivot bolt so you can insert new foottub plates under edge of fiberglass.
3. Install new pivot bolt thru the plate and foottub.
4. Clamp new foottub plate against the back and side of fiberglass.

➤ NOTE: If hole is oversized on foottub, line center of hole in plate with center of molded boss on outside of fiberglass foottub.

5. Drill 3/8" holes through fiberglass, using holes in new foottub plates as guide.
6. Insert 3/8" carriage bolt through from outside of fiberglass through new foottub plate and lock nut into place. 6 bolts and nuts per plate.
7. Install new pivot bolt.
8. Install new all metal locknut on foottub pivot bolt snug so foot tub will still fold up.

❖ WARNING: At least 3 threads of the bolt must protrude from the 5/8" lock nut.

9. Check lap bar latching according to the attached procedure
10. Check foot tub to sweep and gooseneck clearance before operation.
11. Repeat on other side of foottub.

Follow up inspection visually inspect the new plates for corrosion or cracks annually. The original steel can remain in the fiberglass.

Contact Wisdom Industries for replacement plates or bolt on plate kit and longer hinge bolts.

## SIZZLER

### LAP BAR & SEAT LOCK INSPECTION PROCEDURE

1. Raise lap bar and latch.
2. Check lap bar hinge bolts and pipe for wear or looseness.
3. Check lap bar arm for cracks.
4. Check that seat lock brass is tight.
5. Open lap bar.
6. Push seat lock pin. It must snap back out and not drag or catch.
7. Close lap bar. Seat lock pin must snap into the notch in the brass.  
3/8 inch minimum engagement of pin in brass.

> **NOTE: ELECTRIC SEAT UNLOCKING IS NOT MANDATORY.**

8. Activate electric unlocking system.  
**NOTE:** All seat locks should release.
9. Turn off electric unlocking system.  
**NOTE:** The timer will shut off the solenoids after about 15 seconds.
10. Go around seat to inside (spindle side) and pull on the lap bar sideways and out to try to pop seat lock pin out of the brass.
11. If bar comes open, tie off that car until repairs are made. Replace any components needed if the bar will come open.
12. Repeat for each seat.

#### **\*\*WARNING\*\***

Never install a bolt or knob to manually unlock the lapbar. Passengers have been known to open the bar while the ride is running and come out of the seat.

#### **\*\*NOTE\*\***

Each seat lock pin is custom drilled for each car and lap bar. Make sure the same pin goes back to the same bar on the same car.

**INSPECT CLEARANCE OF FOOTTUB TO SWEEP AND TRAILER GOOSENECK.**

**SEE ATTACHED BULLETIN.**

Please notify Wisdom Industries following this inspection and notify us to the status of the bolts on your ride. If you have any questions, please contact Wisdom Industries at 800-634-6097.



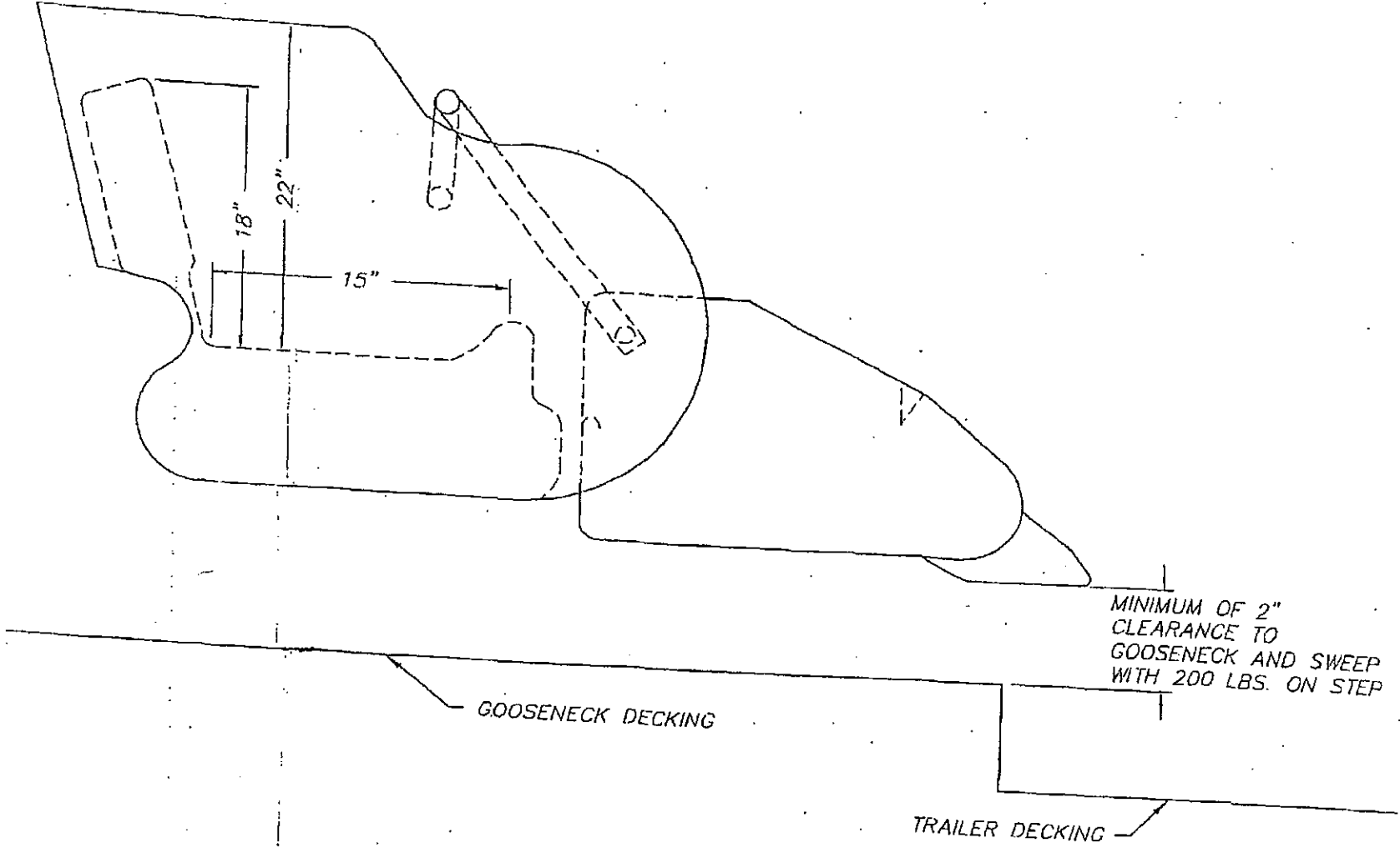

MAY 28, 1997 - 14:07:05 < F:\SIZZ-DWG\SEAT >

REMOVE LOCK NUT FROM FOOT TUB PIVOT BOLT.

SLIDE PIVOT BOLT OUT SO YOU CAN INSERT NEW FOOT TUB PLATES UP UNDER EDGE OF FIBERGLASS .

TAP PIVOT BOLT BACK THRU SO NEW FOOT TUB PLATE IS ON BOLT.

CLAMP NEW FOOT TUB PLATE BACK AGAINST THE BACK AND SIDE OF FIBERGLASS .

NOTE: IF HOLE IS OVERSIZED ON FOOT TUB ALIGN CENTER OF HOLE IN PLATE WITH CENTER OF MOLDED BOSS ON OUTSIDE OF FIBERGLASS FOOT TUB

DRILL 3/8" HOLES THRU FIBERGLASS, USING HOLES IN NEW FOOT TUB PLATES AS GUIDE.

INSERT 3/8" CARRAGE BOLT THRU FROM OUTSIDE OF FIBERGLASS THRU NEW FOOT TUB PLATE AND LOCK NUT TO PLACE. 6 BOLT & NUTS PER PLATE.

REPLACE LOCK NUT ON FOOT TUB PIVOT BOLT. WITH NEW ALL METAL LOCKNUT SNUG SO FOOT TUB WILL STILL FOLD UP.

WARNING: AT LEAST 3 THREADS MUST PROTUDE FROM THE LOCKNUT.

REPEAT ON OTHER SIDE OF FOOT TUB.

CHECK: LAPBAR LATCHING ACCORDING TO ATTACHED PROCEDURE.

CHECK: FOOT TUB TO SWEEP AND GOOSENECK CLEARANCE BEFORE OPERATION.

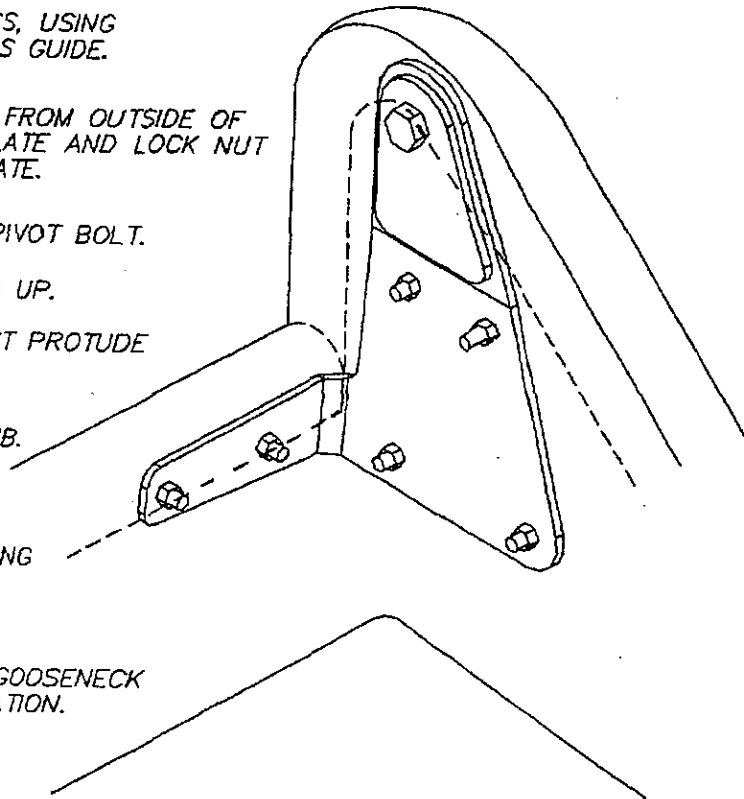

WISDOM INDUSTRIES Merino, CO 80741

APPROVED BY

FOOT TUB BOLT ON PLATE INSTALLATION

SCALE: NTS  
DATE 3-07-05  
DRAWING NUMBER: 015032B

SIZZLER

DESIGNED BY  
M.HICKAM



April 15, 2005

Tom Murray  
Tommy's Midway  
530 East 234th Street, Apt 2D  
Bronx, NY 10470

RE: Sizzler Height Requirements

Dear Mr. Murray:

The height requirements for the Sizzler is 42 inches minimum height to ride. From 42 to 52 inches the passenger must ride with an adult. Over 52 inches can ride alone.

Sincerely,

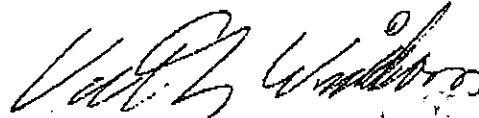

Victor Wisdom  
President  
WISDOM INDUSTRIES, LTD.

*Copy all inspectors  
4/26/05  
LJW*

## Triplett, Michael

---

From: Cares-members-bounces@uscancare.org on behalf of Marcia\_Joiner@cms.state.il.us  
Sent: Wednesday, June 15, 2005 11:28 AM  
To: Cares-members@uscancare.org  
Subject: [Cares-members] Fw: Amusement Ride Safety Alert



ATT932337.txt

Marcia Joiner  
Illinois Department of Labor  
217/782-9397 (voice) - Agency Administrative Office  
217/782-9347 (voice) - Carnival & Amusement Ride Division  
217/782-0596 (fax)  
EMAIL: marcia\_joiner@cms.state.il.us  
WEBSITE: www.state.il.us/agency/idol

----- Forwarded by Marcia Joiner/DOL\_SPF/DOL/ILL on 06/15/2005 10:27 AM  
-----

"dennis" "Topka Ivins,  
Tanya"  
<JeanS@ica.state.az.us>, <TTopkaIvins@cpsc  
<jmeyer@hq.dir.ca.gov>, .gov>  
<john.blaschik@po.state.ct.us>, <mike.watson@mail.state.ar.us>  
<denzil.noble@dc.gov>, 06/15/2005 10:09  
AM <janeen.smith@state.co.us>  
<ynagpaul@aloha.com>, <rward@state.de.us>  
<marcia\_joiner@cms.state.il.us>, <romnesi@doacs.state.fl.us>  
<carl.dills@kyagr.com>, <earl.everett@dol.state.ga.us>  
<stephen.w.dixon@maine.gov>, <gmalmen@dbs.state.id.us>  
<mark.mooney@state.ma.us>, <bfranklin@sema.state.in.us>  
<Joel.Amato@state.mn.us>, <Kathleen.Uehling@iwd.state.ia.us>  
<ghirsh@dol.state.ne.us>, <lroberts@kdhe.state.ks.us>  
<burrougB@safety.state.nh.us>, <bcate@dps.state.la.us>  
<Carmen.Gomez@state.nm.us>, <safe4u@erols.com>  
<cwagner@mail.dol.state.nc.us>, <dndoman@michigan.gov>  
<lllee@ago.state.ms.us>, <wfarr01  
<hreid@state.mt.us>  
<ncad@fyiconsumer.org>  
<hcrane@dca.stat.nj.us>  
<usadir@labor.state.ny.us>  
<drmayer@state.nd.us>

<truex@odant.agri.state.oh.us>,  
<Jim.R.RUNYAN@state.or.us>,  
<jechevarria@daco.gobierno.pr>,  
<scottd@llr.sc.gov>,  
<Duane.Davis@state.tn.us>,  
<fgiani@utah.gov>,  
<ncrumpton@dhcd.state.va.us>,  
<jburgess@labor.state.wv.us>,  
<lleis@state.wy.us>,  
<hmacdonald@tssa.org>,  
<TTopkaIvins@cpsc.gov>,  
<drmayer@state.nd.us>,  
<randy@dfs.state.mo.us>,

<mhollowa@oklaosf.state.ok.us>,  
<jfiloromo@state.pa.us>,  
<MagdyG@gw.doa.state.ri.us>,  
<dave.micklos@state.sd.us>,  
<Richard.Baker@tdi.state.tx.us>,  
<bpoulin@sec.state.vt.us>,  
<valv235@lmi.wa.gov>,  
<dvriezen@commerce.state.wi.us>,  
<andre.paquette@rbq.gov.gc.ca>,  
"Topka Ivins, Tanya"  
<dhankins@westok.net>,  
<amusementrides@buidlings.nyc.gov>,  
<rosworth@dca.state.nj.us>,  
<harrisa@doacs.state.fl.us>  
cc:  
Subject: Amusement Ride Safety Alert

AMUSEMENT RIDE SAFETY ALERT

WISDOM INDUSTRIES, LTD. DELUXE SIZZLER

June 15, 2005

Dear State Amusement Ride Safety Official:

As in the past, staff from the U.S. Consumer Product Safety Commission (CPSC) are providing safety information regarding amusement rides. The enclosed information is being provided to you as part of the Commission's Amusement Ride Safety Information Program. The Commission is authorized to share information with other federal and state agencies under Section 29 of the Consumer Product Safety Act (CPSA), 15 U.S.C. § 2078. In accordance with this section, however, no federal or state agency to whom such information is provided may disclose it to the public until the Commission has complied with the information disclosure requirements of Section 6(b) of the CPSA, 15 U.S.C. § 2055 (b).

A fatal incident occurred May 28, 2005 involving a Deluxe Sizzler in Durango, CO. A similar fatal incident occurred on November 1, 2003 in Mendoze, AZ. The Deluxe Sizzler was manufactured by Wisdom Industries, Ltd. of Sterling, CO. Both incidents involve the same Sizzler, which is operated by Frazier Shows of America. The victims were 14 (CO) and 22 (AZ) years old, and both died after losing consciousness on the Deluxe Sizzler. The

cause of death in both cases was cardiac arrhythmia and the deaths were ruled due to natural causes. The 14 year old female suffered from a pre-existing medical condition that was determined to be the cause of her death. The 22 year old female had recently had surgery and was on medications, and these factors contributed to her death. This alert is to notify you that this ride should have warning signage instructing riders with pre-existing medical conditions or those on medications affecting the heart not to ride. This information is contained in the owner's manual and should be posted clearly on or near the ride.

As you receive information about this portable amusement ride or any other portable device, please do not hesitate to contact me directly at (301) 504-7594. We look forward to continuing work with you to reduce the number of deaths and injuries involving portable amusement rides.

U.S. CPSC

Tanya Topka Ivins

Compliance Officer

Unless otherwise stated, any views or opinions expressed in this e-mail (and any attachments) are solely those of the author and do not necessarily represent those of the U.S. Consumer Product Safety Commission.

Copies of product recall and product safety information can be sent to you automatically via Internet e-mail, as they are released by CPSC. To subscribe or unsubscribe to this service go to the following web page: <http://www.cpsc.gov/cpsclist.asp>



**WISDOM  
INDUSTRIES, Ltd.**

---

## **SIZZLER, DELUXE SIZZLER & SUPER SIZZLER OWNERS**

---

**DATE: JUNE 27, 2005**  
**RIDE: SIZZLER, DELUXE SIZZLER &  
SUPER SIZZLER**  
**SUBJECT: RIDER REQUIREMENTS**

Recently a teenager, with a pre-existing heart condition, died after riding the Sizzler. We are asking all owners to check their Sizzler sign boards to make sure that the boards indicate that passengers with a heart conditions or are taking medications for a heart conditions should not ride the Sizzler, Deluxe Sizzler or Super Sizzler. Review the attached sheet to verify that the information is posted on your ride for the passengers to review before riding the ride.

Many other rides have "G" forces higher than the Sizzler, and it would be a good idea to check with the manufacturer of those rides about similar wording.

Attached is a list of recommended items to be posted on these rides.

If you have any questions please contact Wisdom Industries,  
Ltd. @ 970-522-7515

---

➤ FOR YOUR SAFETY YOU MUST BE:

SIZZLER/DELUXE SIZZLER

42"-52" MUST RIDE WITH AN ADULT  
OVER 52"- CAN RIDE ALONE

SUPER SIZZLER

36"-48" MUST RIDE WITH AN ADULT  
OVER 48"- CAN RIDE ALONE

**GUESTS SHOULD EXPECT:**

- Strong side to side forces
- Rapidly changing turbulent forces
- Strong front to back forces
- Rapidly changing heights

**YOU SHOULD NOT RIDE IF YOU HAVE:**

- Heart Condition or taking medications for Heart Conditions that can be aggravated by the action of the ride
- Pregnancy, Seizures, Dizziness
- Motion Sickness, Back or Neck Disorders
- Other physical ailments which may be aggravated by the motion of the ride

**YOU SHOULD NOT RIDE IF YOU ARE UNABLE TO:**

- Be restrained by a lap bar
- Sit upright
- Hold on

**YOU SHOULD NOT RIDE IF YOU ARE UNDER THE INFLUENCE OF:**

- Drugs
- Alcohol
- Prescription Medication

**PHYSICALLY OR MENTALLY CHALLENGED GUESTS MAY NOT FIND THIS RIDE SUITABLE**

Remain seated. Keep arms, legs, hands & feet inside car at all times. Please be careful entering and exiting the ride as the walking surface may be slippery. Please walk at all times.

Ask for assistance entering or exiting the seats if needed.





**WISDOM  
INDUSTRIES, Ltd.**

# SAFETY BULLETIN

**DATE: FEBRUARY 6, 2006**  
**RIDE: SIZZLER**  
**SUBJECT: SIZZLER LAPBAR MODIFICATION**  
**COMPLIANCE TIME: IMMEDIATE**

**RE: INSTALL A SPREADER TUBE & STEP PLATE  
IN THE LAPBAR.**

1. Install angle cut tube across lapbar.
2. Trim tube to fit between bent tubes.
3. Weld tube to bent tubes.
4. Weld step plate in center of lapbar opening.
5. Prime and paint tube & plate.
6. Repeat for each lapbar.

**> NOTE: KEEP EACH BAR WITH EACH SEAT.**

- **WARNING: IF BAR IS REMOVED FROM SEAT NEW ALL METAL LOCKNUTS MUST BE USED.**
- **WARNING: CHECK LATCHING OF LAPBAR ACCORDING TO THE ATTACHED INSPECTION PROCEDURE.**

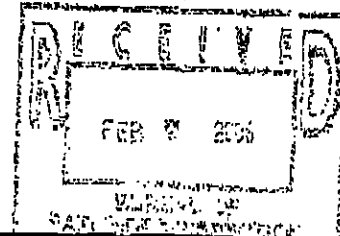

WELD IN TUBE AND STEP PLATE  
AS SHOWN

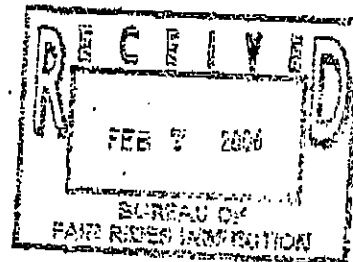
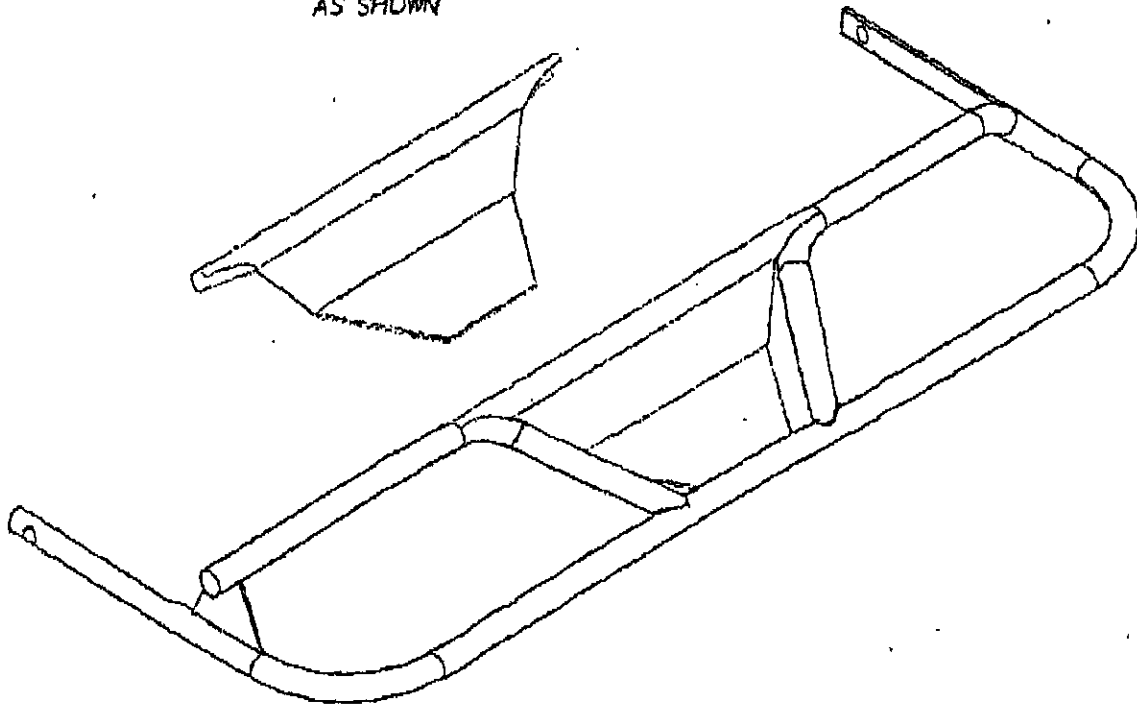

 WISDOM INDUSTRIES Merino, CO 80741

APPROVED BY:

DESCRIPTION

HANDLE BAR MODIFICATION

SCALE: NTS

DATE: 2-8-06

EQUIPMENT

SIZZLER

DRAWN BY

M. HOPKIN

DRAWING NUMBER

FE 400

**SIZZLER  
LAP BAR & SEAT LOCK INSPECTION PROCEDURE**

1. Raise lap bar and latch.
2. Check lap bar hinge bolts and pipe for wear or looseness.
3. Check lap bar arm for cracks.
4. Check that seat lock brass is tight.
5. Open lap bar.
6. Push seat lock pin. It must snap back out and not drag or catch.
7. Close lap bar. Seat lock pin must snap into the notch in the brass.  
3/8" minimum engagement of pin in brass.

➤ **NOTE: ELECTRIC SEAT UNLOCKING IS NOT MANDATORY.**

8. Activate electric unlocking system.  
**NOTE:** All seat locks should release.
9. Turn off electric unlocking system.  
**NOTE:** The timer will shut off the solenoids after about 15 seconds.
10. Go around seat to inside (spindle side) and pull on the lap bar sideways and out to try to pop seat lock pin out of the brass.
11. If bar comes open, tie off that car until repairs are made. Replace any components needed if the bar will come open.
12. Repeat for each seat.

**\*\*WARNING\*\***

Never install a bolt or knob to manually unlock the lapbar.  
Passengers have been known to open the bar while the ride is running and come out of the seat.

