

ZAMPERLA INC.
49 Fanny Road
Parsippany, New Jersey 07054-6545
USA
Phone: 973 334 8133 Fax: 973 334 6880

Bulletin No: 2000 ZZ1
Release Date: 04/06/2000
Effective Date: 04/06/2000
Supersedes:
Completion Date: As soon as possible
Page: 1 of 1

SERVICE BULLETIN

Ride Manufacturer: Zamperla Inc.	Affected Production Dates: 1997
Ride Name: Zig Zag Coaster	Affected Serial Nos.: RC05F271US97
Model Number: Zig Zag Coaster	

Abstract Of Issue:
A new chain design will enhance performance.

Reason For Release:
Same.

Action To Be Taken:
Replace the original welded chain with the new roller chain.

Detail Of Issue:
None

Future Action To Be Taken:
None

<p>ZAMPERLA INC. 49 Fanny Road Parsippany, New Jersey 07054-6545 USA Phone: 973 334 8133 Fax: 973 334 6880</p>	Bulletin No: 2000 ZZ2
	Release Date: 08/01/2000
	Effective Date: 08/01/2000
	Supersedes:
	Completion Date: Annually
Page: 1 of 2	



SERVICE BULLETIN



Ride Manufacturer: Zamperla Inc.	Affected Production Dates: All
Ride Name: Zig Zag Coaster	Affected Serial Nos.: All
Model Number: Zig Zag Coaster	

Abstract Of Issue:

The dog pin under each car requires annual NDT.

Reason For Release:

Same.

Action To Be Taken:

Undergo an NDT procedure on all dog pins as per ASME V SA 388.

Detail Of Issue:

Drawing # 9391048103B (Page 2 of 2)

Future Action To Be Taken:

The NDT procedure on the dog pins must be performed on an annual basis

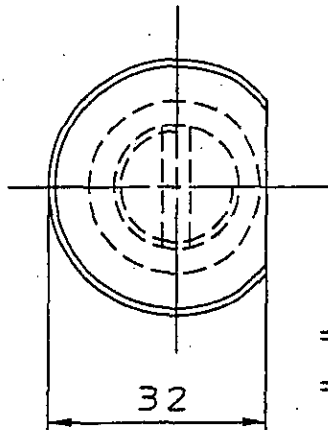
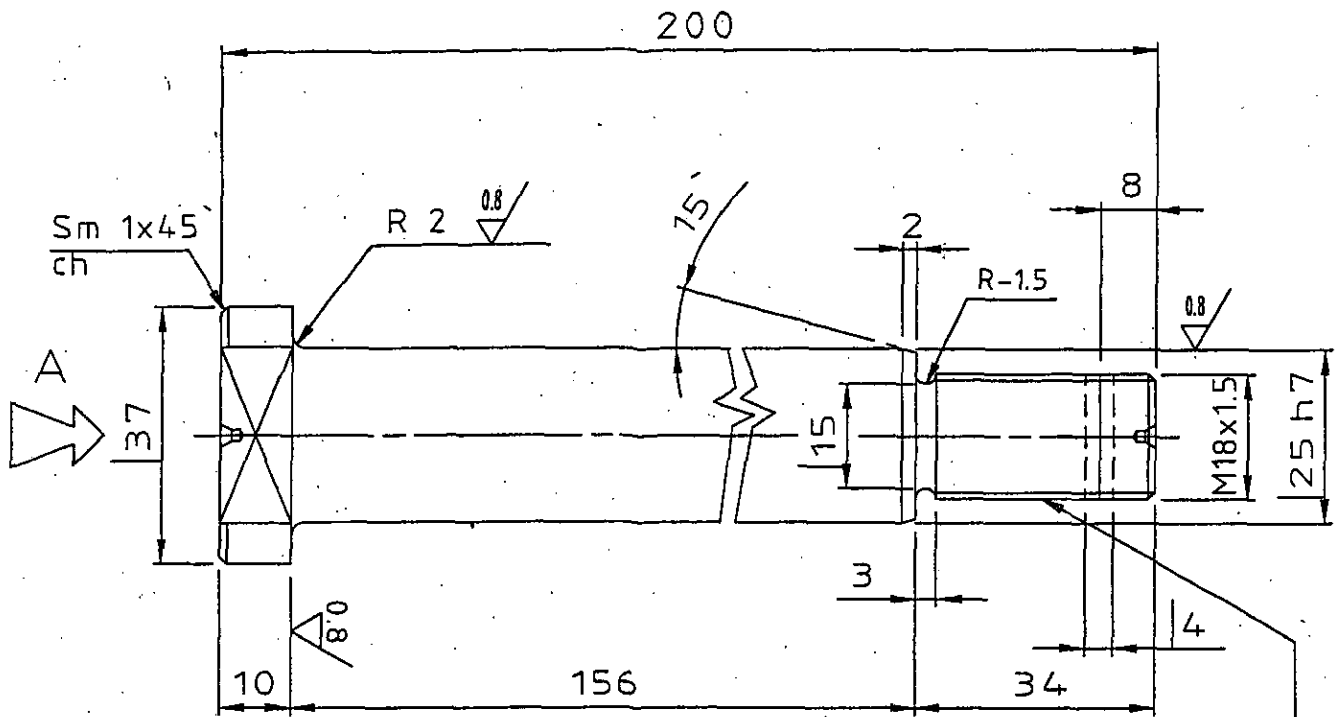

N.B. proteggere la filettatura dalla cementazione

NOTE : The casehardening thread shall be shielded

VISTA DA A
VIEW FROM A

Trattamento termico : CEMENTAZIONE - TEMPRA - RINVENIMENTO
Heat-treatment : CASEHARDENING - HARDENING - TEMPERING

Durezza : 55-60 HRC
Profondita' di cementazione : 0.6mm
Hardness : 55-60 HRC
Casehardening depth : 0.6mm

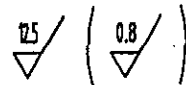

QUOTE SENZA SPECIFIC TOLLER.				POS.	CODICE	N. PEZZI	DESCRIZIONE	MAT.
DA 0	DA 7	DA 31	DA 121					
A 6	A 30	A 120	A 320					
- 0.1	- 0.2	- 0.3	- 0.5					
321	DA 1001	DA 2001	DA 4001					
1000	A 2000	A 4000	A -					
1.8	1.2	2	3					
Materiale				N. Pezzi		Scala		
18 CrNi 8						1:1		
Macchina				A.ZAMPERLA®				
VETTURA ZIG-ZAG / CAR ZIG-ZAG				COSTRUZIONI PER PARCHI DIVERTIMENTO				
				Monta Graepa 15/1736077 ALTAVILLA (VI)				
Disegnato	GAZZOTTI			Gruppo				Questo disegno non puo' essere riprodotto, ne ceduto a terzi e a ditte concorrenti, senza il nostro consenso. Esso viene consegnato a questa espressa condizione.
Data	02-12-97			TELAIO / CHASSIS				
Verificato	FURLAN			Denominazione				
Data	29-12-99			PERNO PER GANCI / PIN				
				N. DIS.		9391048103B		

<p>ZAMPERLA INC. 49 Fanny Road Parsippany, New Jersey 07054-6545 USA Phone: 973 334 8133 Fax: 973 334 6880</p>	Bulletin No: 2000 ZZ2 REV
	Release Date: 08/30/2000
	Effective Date: 08/30/2000
	Supersedes: 2000 ZZ2
	Completion Date: Annually
Page: 1 of 2	



SERVICE BULLETIN



Ride Manufacturer: Zamperla Inc.	Affected Production Dates: All
Ride Name: Zig Zag Coaster	Affected Serial Nos.: All
Model Number: Zig Zag Coaster	

Abstract Of Issue:

The dog pin under each car requires annual NDT.

Reason For Release:

Same.

Action To Be Taken:

Undergo an NDT procedure on all dog pins as per
ASTM "A 388/A388M-86", "E 317-94", "E 428-92"

Detail Of Issue:

Drawing # 9391048103B (Page 2 of 2)

Future Action To Be Taken:

The NDT procedure on the dog pins must be performed on an annual basis

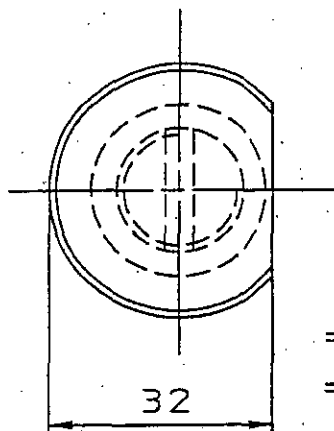
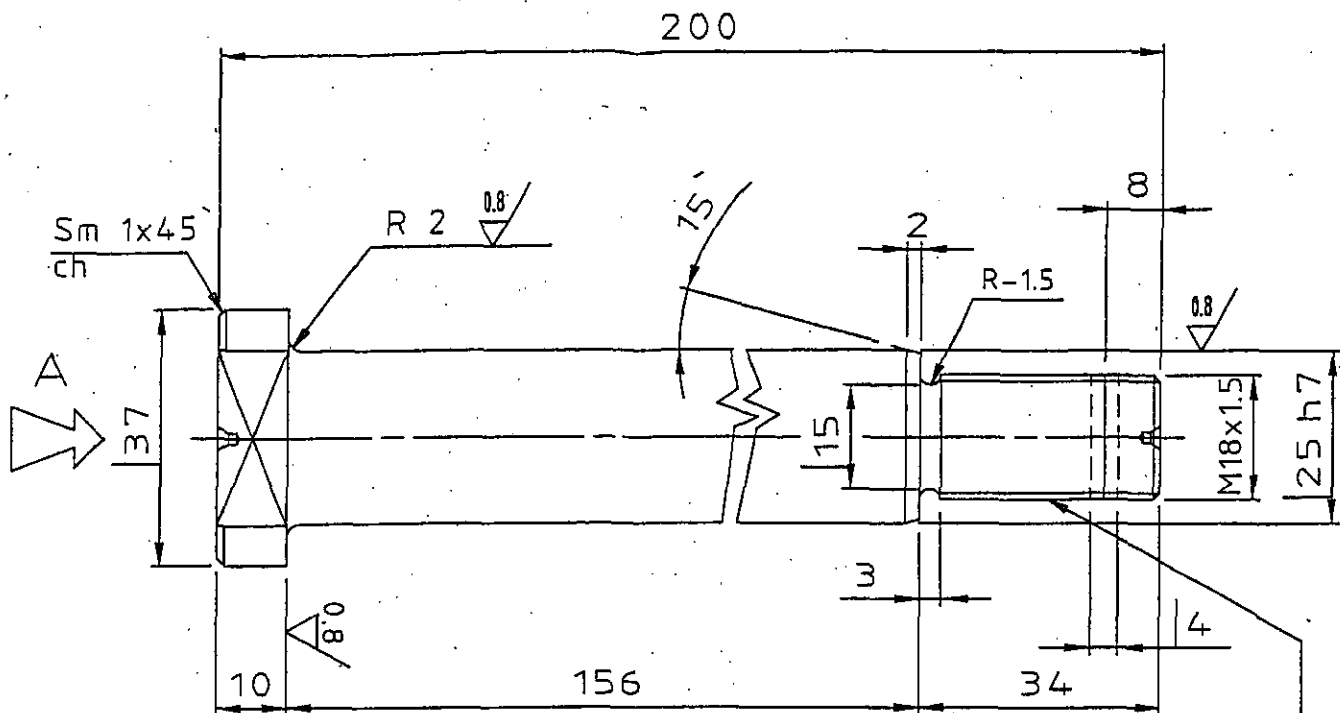

N.B. proteggere la filettatura dalla cementazione

NOTE: The casehardening thread shall be shielded

VISTA DA A
VIEW FROM A

Trattamento termico : CEMENTAZIONE - TEMPRA - RINVENIMENTO
Heat-treatment : CASEHARDENING - HARDENING - TEMPERING

Durezza : 55-60 HRC
Profondita' di cementazione : 0.6mm
Hardness : 55-60 HRC
Casehardening depth : 0.6mm

25 / (0.8)

QUOTE SENZA SPECIFIC.TOLLER.				POS.	CODICE	N. PEZZI	DESCRIZIONE	MAT.
DA 0	DA 7	DA 31	DA 121					
A 6	A 30	A 120	A 320					
M	0.2	0.3	0.5					
321	DA 1001	DA 2001	DA 4001					
.000	A 2000	A 4000	A -					
0.8	12	2	3					
egnato	GAZZOTTI	Gruppo						
	02-12-97	TELAIO / CHASSIS						
ato	FURLAN	Denominazione						
	29-12-99	PERNO PER GANCI / PIN						
				N. DIS.	9391048103B			



COSTRUZIONI PER PARCHI DIVERTIMENTO
Monte Grappa 15/1736077 ALTAVILLA (VI)

Questo disegno non puo' essere riprodotto, ne caduto a terzi o a ditte concorrenti, senza il nostro consenso. Esso viene consegnato a queste espressa condizioni.

ZAMPERLA INC.
49 Fanny Road
Parsippany, New Jersey 07054-0598

USA
Phone: 973 334 8133 Fax: 973 334 6880

Bulletin No: 2001ZZ1

Release Date: September 17, 2001

Effective Date: September 17, 2001

Supersedes:

Completion Date: Three years from the
installation date of the ride.

Page: 1 of 31

SERVICE BULLETIN

Ride Manufacturer: Zamperla SPA

Affected Production Dates: All

Ride Name: Zig Zag Roller Coaster

Affected Serial Nos.: All

Model Number: Zig Zag Roller Coaster

Abstract Of Issue:

There is an NDT requirement for some train components.

Reason For Release:

Same

Action To Be Taken:

Perform dye penetrant test on the components of the train using the attached drawings. Replace the component if any cracks are detected. Perform visual inspection and if necessary Magnetic Particle test of the welds of the wheel carriers and under carriage components. Repair damaged welds using the attached welding procedure.

Detail Of Issue:

Drawings of the train components (5 pages), Dye Penetrant Examination #PT 89010 (7 pages), Magnetic Particle Examination # MT 89005 (9 pages), Welding Procedure WEL-P-10 Rev A (10 pages).

Future Action To Be Taken:

Perform the dye penetrant test on an annual basis. Perform the visual inspection on a monthly basis.